



New Product Announcement

ZXMN20B28K
ZXMN15A27K

MOSFETs optimised for Voice over Internet Protocol (VoIP)

Diodes Incorporated has extended its family of MOSFETs tailored for VoIP communication equipment.

The ZXMN20B28K and ZXMN15A27K are avalanche rugged and designed for driving transformers in the DC-DC converter stage of Subscriber Line Interface Circuits (SLIC).

These MOSFETs combined with a transformer allow a wide range of battery voltage (V_{BAT}) to be efficiently converted in the SLIC. This eliminates high voltage external power supplies that are bulky and expensive.

SLICs are the gateway for VoIP applications in the exchange and can be used for interfacing with a range of different end equipment including Cable (EMTA), DSL modems (IAD) and Analog Terminal Adapters. As well as Private Branch Exchanges including IP-PBX.

VoIP enables a lower total cost of ownership whilst providing more services to the end-user.

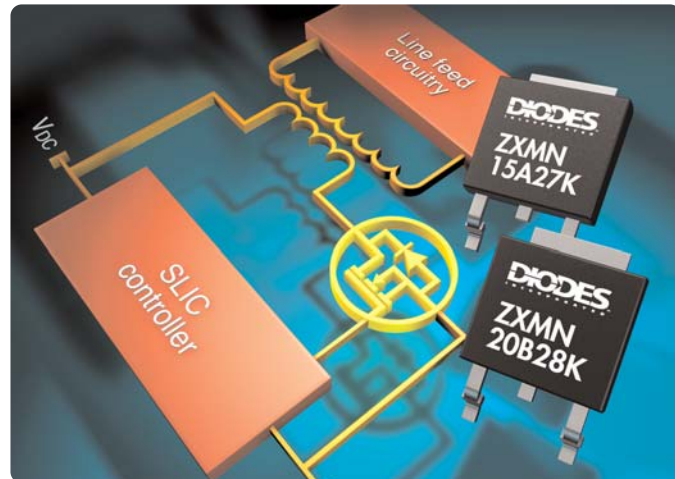

The Diodes' Advantage

The ZXMN20B28K and ZXMN15A27K are N-channel MOSFETs designed to meet the stringent circuit requirements in the DC-DC conversion stage of SLICs.

- **High breakdown voltage (V_{DSS}) and Pulse Current (I_{DM})**

With 200V and 150V V_{DSS} , then V_{BAT} exceeding 150V can be driven into multiple subscriber lines with lengths beyond 6km. Also, with high I_{DM} handling capabilities, the MOSFETs can drive the transformer to deliver the required RING and TIP currents.

- **Avalanche rugged**

Both MOSFETs have been designed to withstand the high pulse avalanche energy that will be induced by the transformer during switching transition.

- **Low gate charge (Q_g) and input capacitance (C_{iss})**

Low Q_g and C_{iss} means that both MOSFETs can be driven with minimal or no buffering. This simplifies the SLIC design and reduces component count and cost. The ZXMN20B28K is also capable of being driven at low logic level voltages.

- **AEC-Q101, "Green" and RoHS Compliant**

The ZXMN20B28K and ZXMN15A27K are qualified to AEC-Q101 standard, are RoHS compliant and contain no halogens or antimony compounds.

Circuit Function

For generating the V_{BAT} required for driving the RING and TIP linefeed output of SLICs, an on-board DC-DC converter using MOSFET-transformer is the most suitable.

- **Increased efficiency**

The MOSFET and transformer DC-DC conversion has a greater power efficiency than the equivalent solution using a bipolar transistor (BJT) and inductor. Typically the efficiency can be increased from 67% to 80%.

- **Low DC supply voltage (V_{DC})**

The MOSFET and transformer is the preferred solution for SLICs with low V_{DC} .

MOSFETs optimised for Voice over Internet Protocol (VoIP)

Diodes' MOSFETs for transformer based DC-DC converters

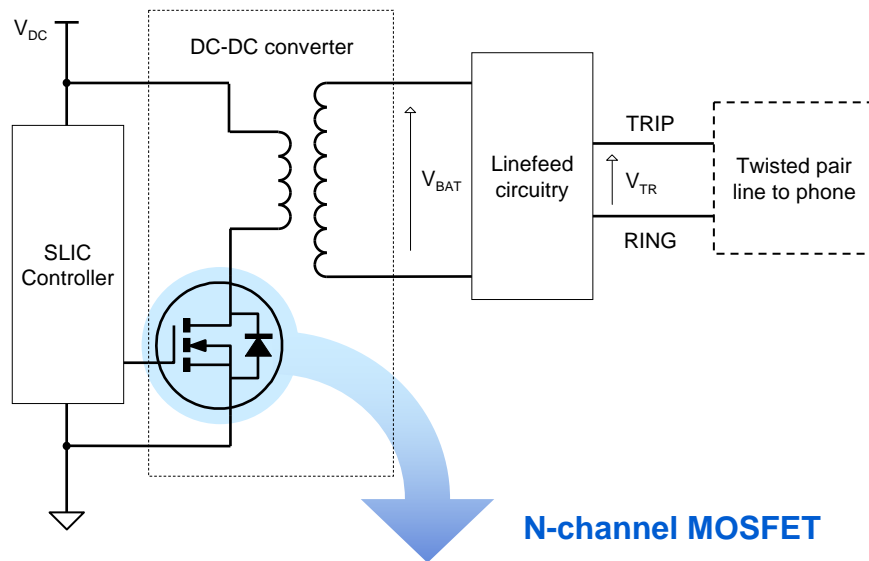

| Part Name | Pack | V _{DSS} (V) | P _D (W) | I _D (A) | I _{DM} (A) | R _{DS(on)} max (mΩ) @ V _{GS} | | | C _{iss} Typ (pF) | Q _g Typ (nC) @5V | Q _g Typ (nC) @10V | E _{AS} UIS (Note 1) |
|------------|----------|----------------------|--------------------|--------------------|---------------------|---|-----|-----|---------------------------|--------------------------------|---------------------------------|------------------------------|
| | | | | | | 5V | 6V | 10V | | | | |
| ZXMN20B28K | TO252-3L | 200 | 10.2 | 2.3 | 17.3 | 780 | - | 750 | 358 | 8.1 | 12.9 | Yes (Note 2) |
| ZXMN15A27K | TO252-3L | 150 | 9.5 | 2.6 | 17.2 | - | - | 650 | 169 | - | 6.6 | Yes (Note 3) |
| ZXMN10A25K | TO252-3L | 100 | 9.9 | 6.4 | 21.0 | - | 150 | 125 | 859 | 9.6 | 17.2 | No |
| ZXMN10A08G | SOT223 | 100 | 3.9 | 2.9 | 11.0 | - | 300 | 250 | 405 | 4.2 | 7.7 | No |
| ZXMN10A11K | TO252-3L | 100 | 8.5 | 3.5 | 9.9 | - | 450 | 350 | 274 | 3.0 | 5.4 | No |
| ZXMN10A11G | SOT223 | 100 | 3.9 | 2.4 | 7.9 | - | 450 | 350 | 274 | 3.0 | 5.4 | No |
| ZXMN7A11K | TO252-3L | 70 | 8.5 | 6.1 | 17.0 | 190 | - | 130 | 298 | 4.4 | 7.4 | No |
| ZXMN7A11G | SOT223 | 70 | 3.9 | 3.8 | 10.0 | 190 | - | 130 | 298 | 4.4 | 7.4 | No |
| ZXMN6A25N8 | SO-8 | 60 | 2.8 | 5.7 | 25.7 | 70 | - | 50 | 1063 | 11.0 | 20.4 | No |
| ZXMN6A08G | SOT223 | 60 | 3.9 | 5.3 | 20.0 | 150 | - | 80 | 459 | 4.0 | 5.8 | No |
| ZXMN6A08E6 | SOT23-6 | 60 | 1.7 | 3.5 | 16.0 | 150 | - | 80 | 459 | 4.0 | 5.8 | No |
| ZXMN6A11G | SOT223 | 60 | 3.9 | 4.4 | 15.6 | 180 | - | 120 | 330 | 3.0 | 5.7 | No |

Notes: 1. Single pulse avalanche energy (E_{AS}) testing using an Unclamped Inductive Switch (UIS) test in production.
2. E_{AS} = 73mJ with UIS conditions of L = 4.83mH, I_{AS} = 5.5A, R_G = 25Ω, V_{DD} = 100V, starting T_J = 25°C.
3. E_{AS} = 55mJ with UIS conditions of L = 5.95mH, I_{AS} = 4.3A, R_G = 25Ω, V_{DD} = 100V, starting T_J = 25°C.