



CHENMKO ENTERPRISE CO.,LTD

SURFACE MOUNT

SCHOTTKY BARRIER RECTIFIER

VOLTAGE RANGE 20 - 40 Volts CURRENT 3.0 Ampere

Lead free devices

SMD32PT

THRU

SMD34PT

FEATURES

- * Plastic package has Underwriters Laboratory Flammability Classification 94V-0
- * For surface mounted applications
- * Low profile package
- * Built-in strain relief
- * Metal silicon junction, majority carrier conduction
- * Low power loss, high efficiency
- * High current capability, low forward voltage drop
- * High surge capability
- * For use in low voltage high frequency inverters, free wheeling, and polarity protection applications
- * High temperature soldering guaranteed : 260°C/10 seconds at terminals

MECHANICAL DATA

Case: JEDEC SOD-123 molded plastic
Terminals: Solder plated, solderable per MIL-STD-750, Method 2026
Polarity: Color band denotes cathode end
Weight: 0.001 ounce 0.032 gram

MAXIMUM RATINGS AND ELECTRICAL CHARACTERISTICS

Ratings at 25°C ambient temperature unless otherwise specified.
 Single phase, half wave, 60 Hz, resistive or inductive load.
 For capacitive load, derate current by 20%.



SOD-123

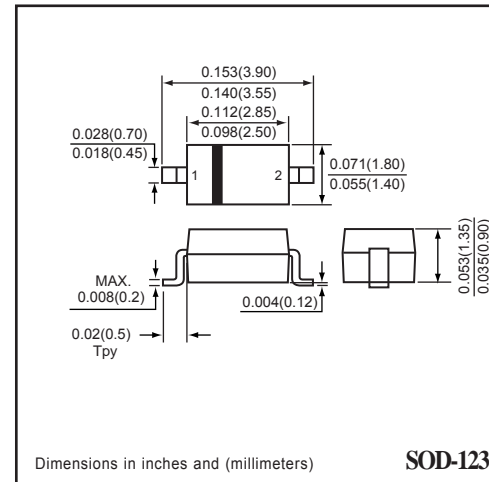

MAXIMUM RATINGS (At TA = 25°C unless otherwise noted)

RATINGS	SYMBOL	SMD32PT	SMD33PT	SMD34PT	UNITS
Maximum Recurrent Peak Reverse Voltage	VRRM	20	30	40	Volts
Maximum RMS Voltage	VRMS	14	21	28	Volts
Maximum DC Blocking Voltage	VDC	20	30	40	Volts
Maximum Average Forward Rectified Current at TL = 45°C	Io	3.0			Amps
Peak Forward Surge Current 8.3 ms single half sine-wave superimposed on rated load (JEDEC method) TL = 45°C	IFSM	40			Amps
Typical Junction Capacitance (Note 2)	CJ	210			pF
Typical Thermal Resistance (Note 1)	R θJL	80			°C / W
Storage and Operating Temperature Range	TJ, TSTG	-65 to +125			°C

ELECTRICAL CHARACTERISTICS (At TA = 25°C unless otherwise noted)

CHARACTERISTICS	SYMBOL	SMD32PT	SMD33PT	SMD34PT	UNITS
Maximum Instantaneous Forward Voltage at 3.0 A DC	VF	0.85	0.9	1.0	Volts
Maximum Average Reverse Current at Rated DC Blocking Voltage	@ TA = 25°C	1.0			mAmps
	@ TA = 100°C	10			mAmps

NOTES : 1. Thermal Resistance (Junction to Lead) : PC Board Mounted on 0.2 X 0.2" (5 X 5mm) copper pad area.
 2. Measured at 1.0 MHz and applied reverse voltage of 4.0 volts

2007-01

RATING CHARACTERISTIC CURVES (SMD32PT THRU SMD34PT)

FIG. 1 - TYPICAL FORWARD CURRENT DERATING CURVE

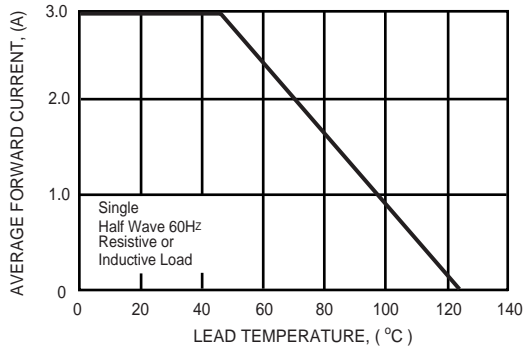

FIG. 2 - TYPICAL INSTANTANEOUS FORWARD CHARACTERISTICS

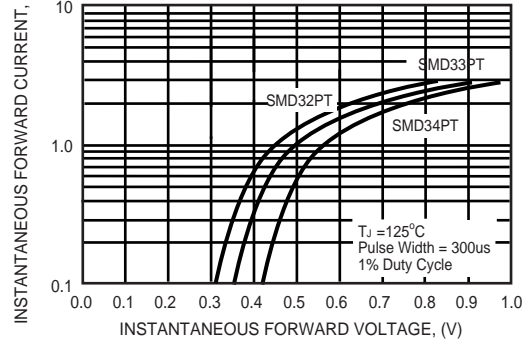

FIG. 3 - TYPICAL REVERSE CHARACTERISTICS

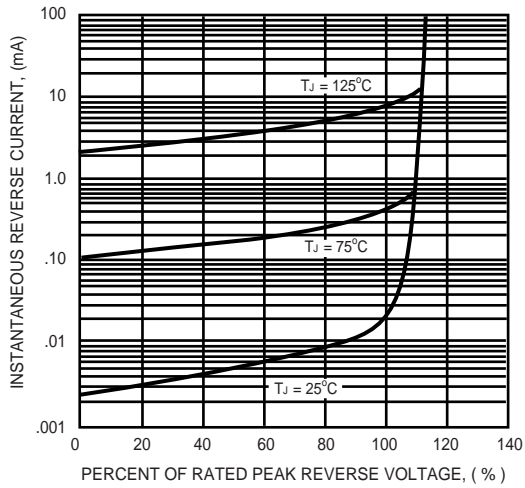

FIG. 4 - MAXIMUM NON-REPETITIVE FORWARD SURGE CURRENT

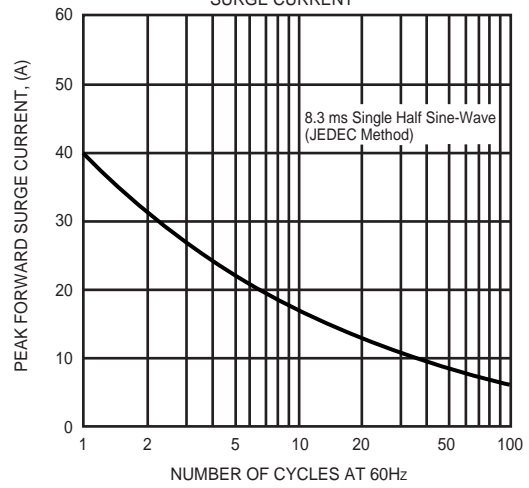

FIG. 5 - TYPICAL JUNCTION CAPACITANCE

