

## MTX9509 and MRX9509

12 Channel Parallel Optical TX and RX Modules,  
1.25 Gbps per Channel

### Applications

- Optical backplanes
- Ganged serial links
- Very Short Reach SONET
- Logic-logic data links
- Board-to-board and shelf-to-shelf

### Features

- Single +3.3V power supply
- Power Consumption 1.5 Watts typ.
- 100-pin matrix array electrical connector
- MPO Optical connector
- CML data path inputs and outputs, with support for both AC and DC coupled IO
- Zero to 80 °C case temperature range

### Compliance

- Fits in SNAP12 MSA sockets
- Eye safety: Class 1M laser product per EN609825-1 and FDA/CDRH
- Electromagnetic Emissions: FCC part 15 - Class B (Residential), EN55022 (Formerly CISPR 22)
- Electromagnetic Immunity: EN61000-4-3, GR-1089-CORE Section 3.3

The MTX9509 and MRX9509 are cost-effective high-speed transmitter (TX) and receiver (RX) modules for use as parallel optical data communication links. The modules perform logic-to-light and light-to-logic conversions for data transmission over multi-mode fiber ribbon cable, at a wavelength of 850 nm.

The transmitter module uses a 1x12 oxide-confined VCSEL array. The receiver uses a high-speed photodiode array.

For optical cable connections, both modules use industry standard IEC 1754-7 MPO connector receptacles. For electrical connections, both modules use widely accepted 100 pin matrix-array connectors.

**Mechanical Interface**

**Package Dimensions**

A common package format is used for both the MTX9509 transmitter and MRX9509 receiver modules; see image on cover page. The only difference between the modules is the position of the electrical receptacle relative to the mounting feet.

**MODULE DIMENSIONS**

Key	Value mm	Tolerance mm
A1	35.37	±0.25
B1	16.75	±0.25
C1	14.50	±0.25
D1	3.10	±0.25
E1	12.12	±0.25
F1	7.43	±0.25
G1	12.50	±0.25
H1	4.44	±0.25
J1	0.381	±0.12
K1	0.76	±0.12
L1	31.75	±0.50
M1	30.23	±0.12
N1	13.72	±0.12
P1	1.14	±0.12
R1	19.43	±0.12
S1	∅3.80	±0.25
T1	THREAD	—
U1	16.89	±0.12
V1	∅1.30	±0.12
W1	∅2.50	±0.25
X1	28.42	±0.5
Y1	7.80	±0.5
Z1	41.00	±0.5
AE1	8.38	±0.25
AF1	2.30	±0.01
AH1	7.50	±0.1

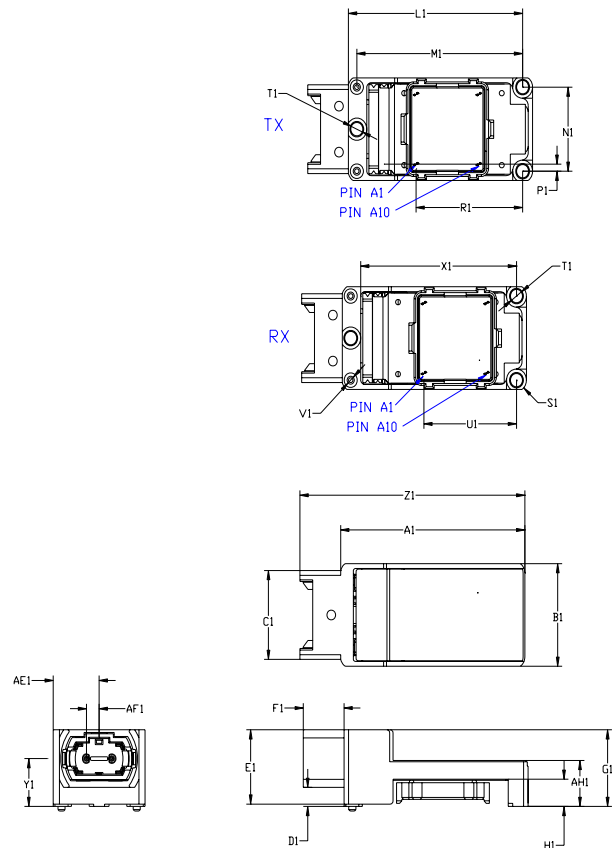

**MODULE DIMENSIONS**

*Tolerancing per ASME Y14.5M-1994. All dimensions are in mm.*

**Product Disclaimer**

EMCORE reserves the right to alter product specifications, features, capabilities, and functions or to discontinue products at any time without notice.

**Ordering Information**

**MTX9510-FB      12 Channel Parallel Optical TX Module – 1.25 Gbps per Channel – with Flat Base for customer-provided heat sink**

**MRX9510-FB      12 Channel Parallel Optical RX Module – 1.25 Gbps per Channel – with Flat Base for customer-provided heat sink**

**MTX9510-HS      12 Channel Parallel Optical TX Module – 1.25 Gbps per Channel – with heat sink**

**MRX9510-HS      12 Channel Parallel Optical RX Module – 1.25 Gbps per Channel – with heat sink**

**Contact Information**

For more information on this application note, related application notes or related products please contact:

Sales — EMCORE Fiber Optics Division  
fiberoptics@emcore.com  
EMCORE Corporation  
1600 Eubank Blvd SE  
Albuquerque, New Mexico 87123  
Tel: (505) 559-2600  
Fax: (505) 323-3430

---

**Product Disclaimer**

EMCORE reserves the right to alter product specifications, features, capabilities, and functions or to discontinue products at any time without notice.

Copyright © 2006 EMCORE Corporation