

HBT DIGITAL PHASE-FREQUENCY DETECTOR, DC - 1.3 GHz

Typical Applications

This Phase Frequency Detector is a key component in low phase noise frequency synthesis applications such as:

- VSAT
- Pt-Pt and Pt-MPt Radios
- LMDS
- Sonnet

Features

- 1.3 GHz Operation
- Low SSB Phase Noise Floor:
-135 dBc/Hz at 100 KHz Offset
- Differential Input/Single Ended Output
- Output Buffer Amplifiers
- 8-Lead SOIC SMT Package

Functional Diagram

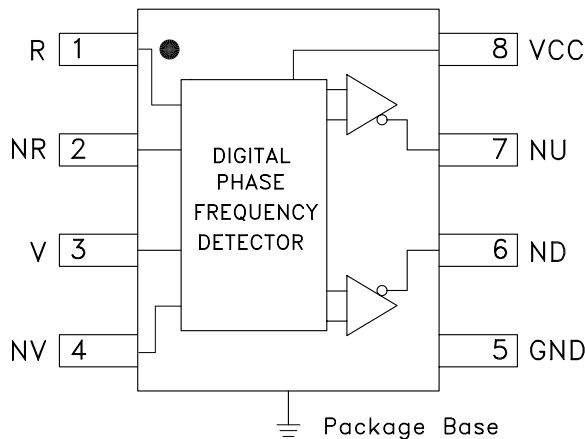

General Description

The HMC403S8G is a digital phase-frequency detector intended for use in low noise phase-locked loop applications. Its combination of high frequency of operation along with its low phase noise floor make possible synthesizers with wide loop bandwidth and low N resulting in fast switching and very low phase noise. When used in conjunction with a differential loop amplifier, the HMC403S8G generates an output voltage that can be used to phase lock a VCO to a reference oscillator. The device is available in a small out-line 8-lead SOIC plastic package.

Electrical Specifications, $T_A = +25^\circ C, V_{CC} = 5V$

Parameter	Conditions	Min.	Typ.	Max.	Units
Maximum Input Frequency		1.3			GHz
Minimum Input Frequency	Sine Wave Input [1]			0.1	GHz
Input Power Range	$F_{in} = 0.1$ to 1.3 GHz	-10		+10	dBm
Output Voltage	$ Z_{Load} \geq 1k \Omega$		740		mV, Pk - Pk
SSB Phase Noise	@ 100 kHz Offset with 800 MHz Input		-135		dBc/Hz
Supply Current			86		mA

1. Detector will operate down to DC for square-wave input signal.

HBT DIGITAL PHASE-FREQUENCY DETECTOR, DC - 1.3 GHz

Error Voltage vs. Phase Difference, Pin= 0 dBm, T= 25 °C *

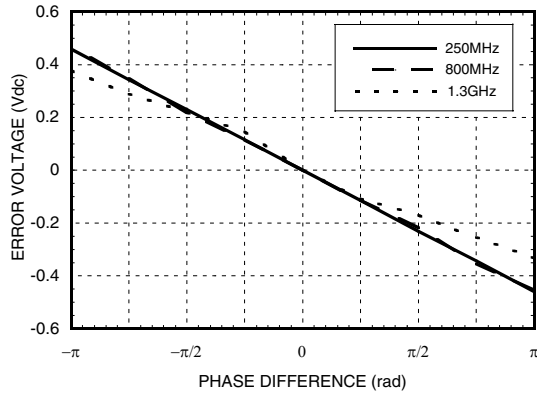

Error Voltage vs. Phase Difference, Pin= 0 dBm, Fin= 800 MHz *

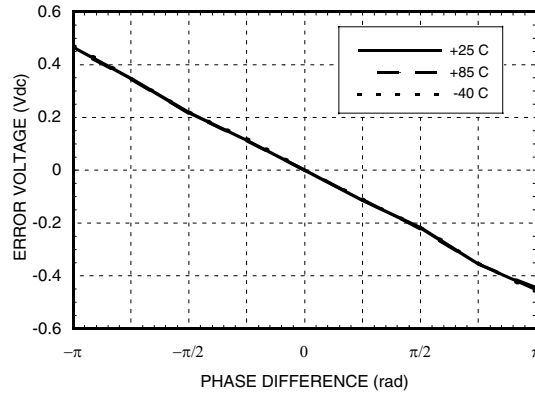

Test Circuit:

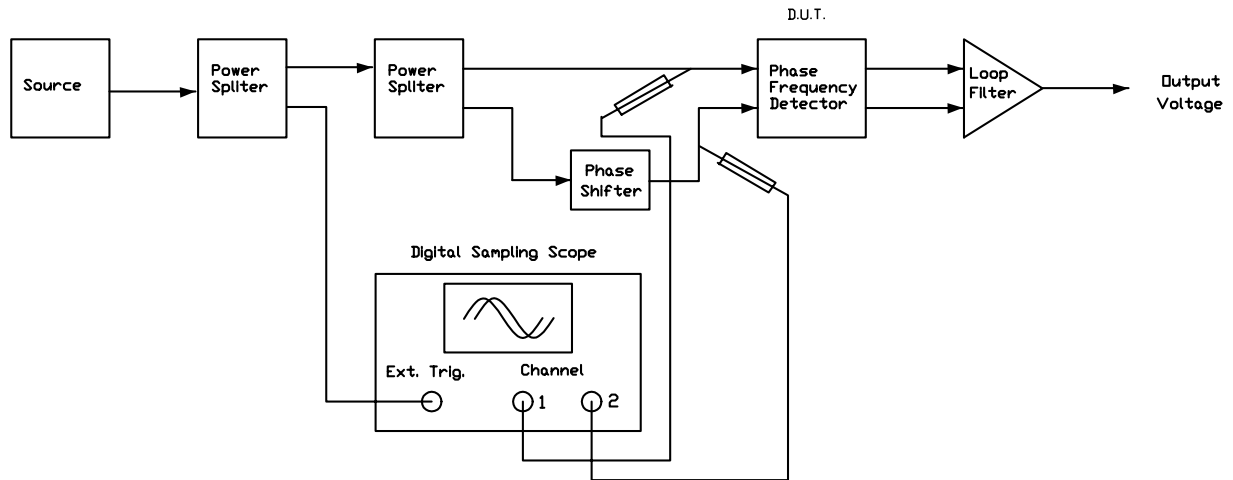

* Error Voltage data taken using test circuit above. Loop filter gain has been subtracted from the result.

HBT DIGITAL PHASE-FREQUENCY DETECTOR, DC - 1.3 GHz

SSB Phase Noise Performance,
Pin= 0 dBm, T= 25 °C

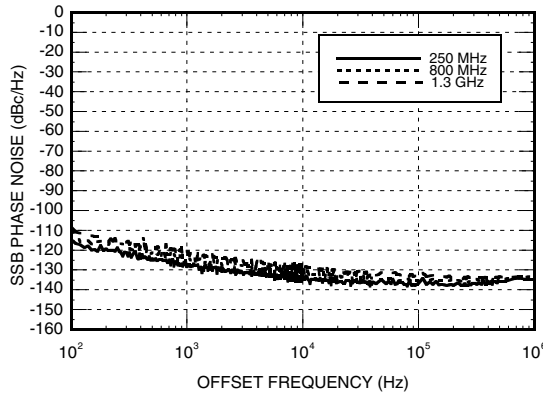

SSB Phase Noise Performance,
Pin= 0 dBm, Fin= 800 MHz

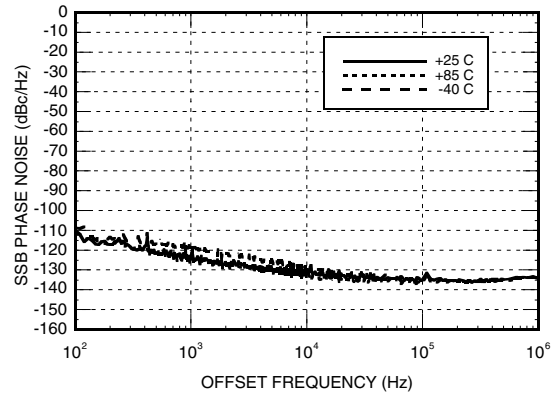

Supply Current vs. Supply Voltage

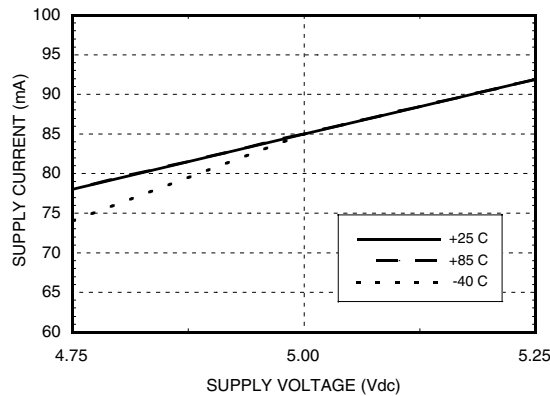

Typical DC Characteristics

Symbol	Characteristics	-40C			+25C			+85C			Unit
		Min.	Typ.	Max.	Min.	Typ.	Max.	Min.	Typ.	Max.	
Icc	Power Supply Current	75	85	92	79	86	92	79	86	92	mA
Voh	Output High Voltage	1.652	1.867	2.086	1.761	1.981	2.214	1.955	2.19	2.411	V
Vol	Output Low Voltage	1.012	1.107	1.286	1.081	1.241	1.414	1.275	1.45	1.631	V

HBT DIGITAL PHASE-FREQUENCY DETECTOR, DC - 1.3 GHz

Absolute Maximum Ratings

RF Input (Vcc = +5V)	+13 dBm
Vcc	+5.5V
Surge Current (Pins ND & NU)	4 mA
DC Current (Pins ND & NU)	2 mA
Storage Temperature	-65 to +150 °C
Operating Temperature	-40 to +85 °C

Outline Drawing

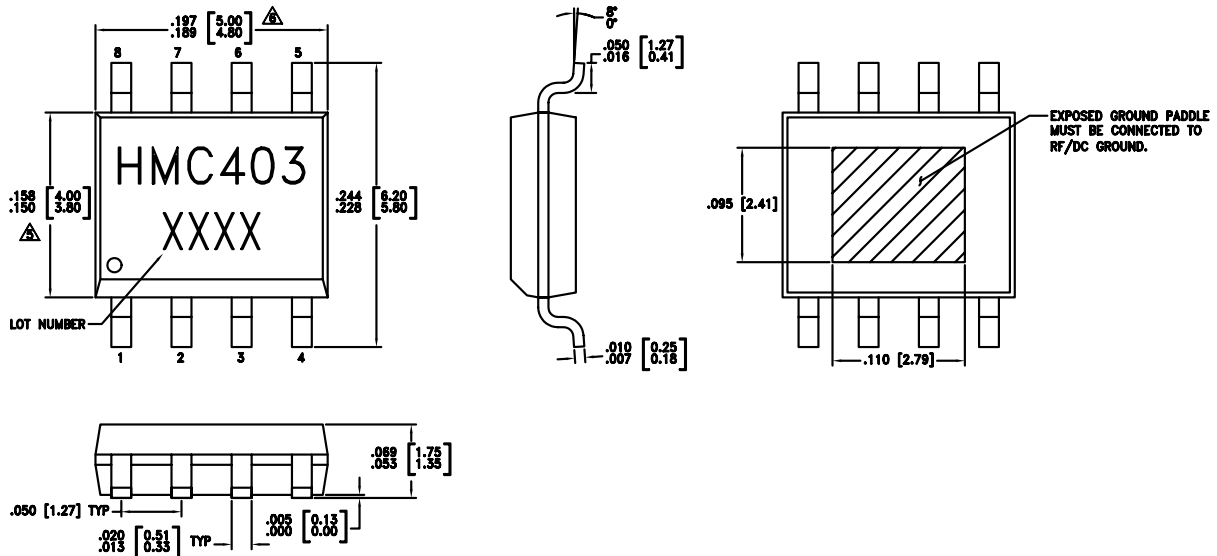



NOTES:

1. PACKAGE BODY MATERIAL: LOW STRESS INJECTION MOLDED PLASTIC SILICA AND SILICON IMPREGNATED.
2. LEADFRAME MATERIAL: COPPER ALLOY
3. LEADFRAME PLATING: Sn/Pb SOLDER
4. DIMENSIONS ARE IN INCHES [MILLIMETERS].
5. DIMENSION DOES NOT INCLUDE MOLDFLASH OF 0.15mm PER SIDE.
6. DIMENSION DOES NOT INCLUDE MOLDFLASH OF 0.25mm PER SIDE.
7. ALL GROUND LEADS AND GROUND PADDLE MUST BE SOLDERED TO PCB RF GROUND.

HBT DIGITAL PHASE-FREQUENCY DETECTOR, DC - 1.3 GHz

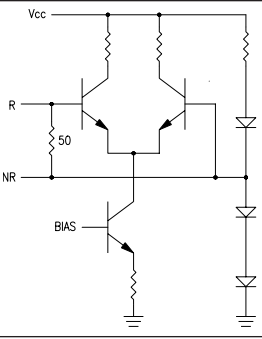
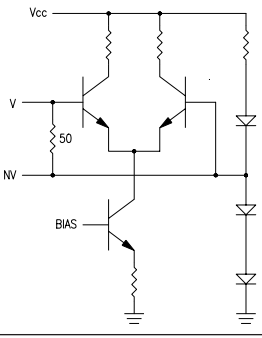
Pin Description

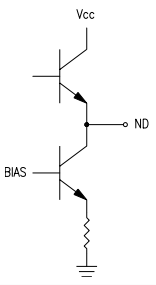
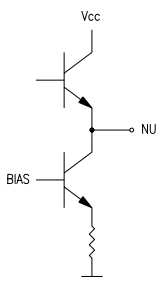
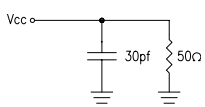
Pin Number	Function	Description	Interface Schematic
1	R	Reference input.	
2	NR	Reference input complement.	
3	V	VCO input.	
4	NV	VCO input complement.	
5	GND	Ground: Backside of package has exposed metal ground slug which must be connected to ground.	
6	ND	Down output complement (Device will be permanently damaged if pin is instantaneously shorted to ground. A minimum load impedance magnitude of 1kΩ is required.)	
7	NU	Up output complement. (Device will be permanently damaged if pin is instantaneously shorted to ground. A minimum load impedance magnitude of 1kΩ is required.)	
8	Vcc	Supply Voltage.	

For price, delivery, and to place orders, please contact Hittite Microwave Corporation:
 12 Elizabeth Drive, Chelmsford, MA 01824 Phone: 978-250-3343 Fax: 978-250-3373
 Order Online at www.hittite.com

HBT DIGITAL PHASE-FREQUENCY DETECTOR, DC - 1.3 GHz

Application Circuit

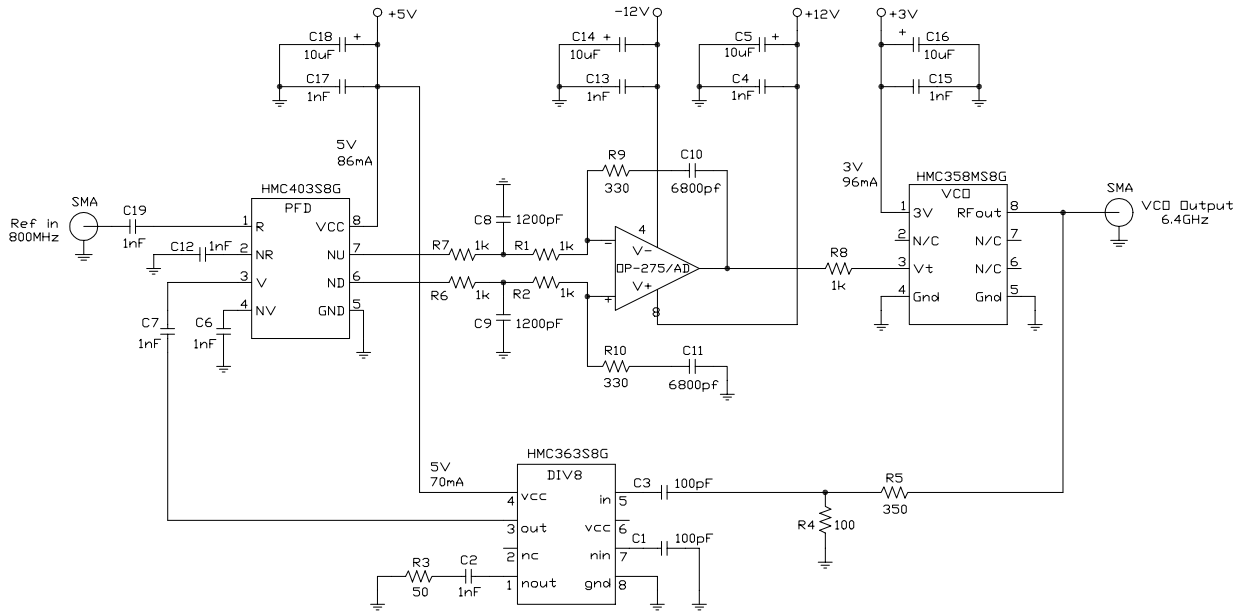

Note: Pins NU and ND should only be probed with high impedance probes.

HBT DIGITAL PHASE-FREQUENCY DETECTOR, DC - 1.3 GHz

Evaluation PCB

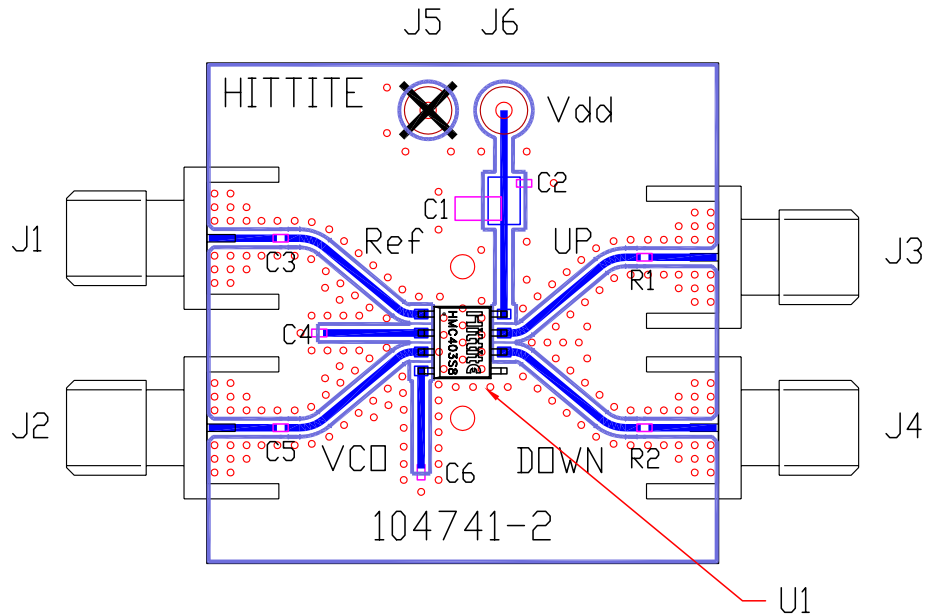

List of Materials

Item	Description
J1 - J4	PC Mount SMA RF Connector
J5 - J6	DC Pin
C1	4.7 μ F Capacitor
C2 - C6	1000 pF Capacitor, 0402 Pkg.
R1 - R2	1000 Ohm Resistor, 0402 Pkg.
U1	HMC403S8G
PCB*	104741 Eval Board
* Circuit Board Material: Rogers 4350	

The circuit board used in the final application should use RF circuit design techniques. Signal lines should have 50 ohm impedance while the package ground leads and backside ground slug should be connected directly to the ground plane similar to that shown. A sufficient number of via holes should be used to connect the top and bottom ground planes. The evaluation circuit board shown is available from Hittite upon request.

HBT DIGITAL PHASE-FREQUENCY DETECTOR, DC - 1.3 GHz

Notes: