

FEATURES

- Tri-axis, 14-bit digital gyroscope with digital range scaling**
±75°/sec, ±150°/sec, ±300°/sec settings
- Tri-axis, 14-bit digital accelerometer**
±5 g measurement range
- 330 Hz bandwidth**
- 180 ms start-up time**
- Factory-calibrated sensitivity, bias, and axial alignment**
- Digitally controlled bias calibration**
- Digitally controlled sample rate, up to 819.2 SPS**
External clock input enables sample rates up to 1200 SPS
- Digitally controlled filtering**
- Programmable condition monitoring**
- Auxiliary digital input/output**
- Digitally activated self-test**
- Programmable power management**
- Embedded temperature sensor**
- SPI-compatible serial interface**
- Auxiliary, 12-bit ADC input and DAC output**
- Single-supply operation: 4.75 V to 5.25 V**
- 2000 g shock survivability**
- Operating temperature range: -40°C to +105°C**

APPLICATIONS

- Medical instrumentation
- Robotics
- Platform control
- Navigation

GENERAL DESCRIPTION

The ADIS16364 *iSensor*® is a complete inertial system that includes a tri-axis gyroscope and tri-axis accelerometer. Each sensor in the ADIS16364 combines industry-leading *iMEMS*® technology with signal conditioning that optimizes dynamic performance.

The factory calibration characterizes each sensor for sensitivity, bias, alignment, and linear acceleration (gyro bias). As a result, each sensor has its own dynamic compensation for correction formulas that provide accurate sensor measurements over a temperature range of -40°C to +85°C.

The ADIS16364 provides a simple, cost-effective method for integrating accurate, multi-axis, inertial sensing into industrial systems, especially when compared with the complexity and investment associated with discrete designs.

FUNCTIONAL BLOCK DIAGRAM

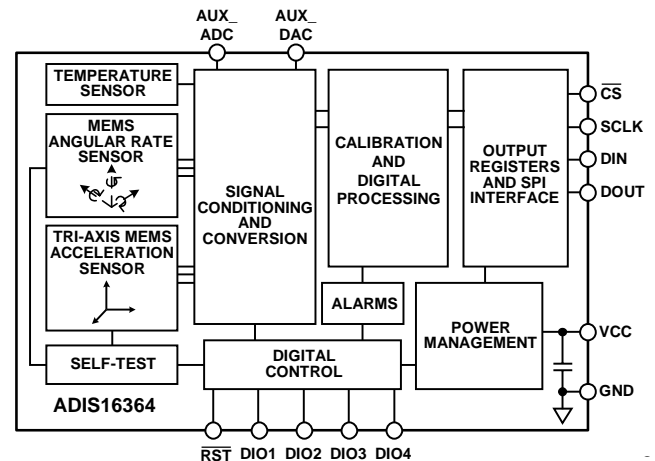

Figure 1.

All necessary motion testing and calibration are part of the production process at the factory, greatly reducing system integration time. Tight orthogonal alignment simplifies inertial frame alignment in navigation systems. An improved SPI interface and register structure provide faster data collection and configuration control. By using a compatible pinout and the same package as the ADIS1635x family, systems that currently use the ADIS1635x family can upgrade their performance with minor firmware changes to accommodate scale factor adjustments.

This compact module is approximately 23 mm × 23 mm × 23 mm and provides a flexible connector interface, which enables multiple mounting orientation options.

Rev. PrA

Information furnished by Analog Devices is believed to be accurate and reliable. However, no responsibility is assumed by Analog Devices for its use, nor for any infringements of patents or other rights of third parties that may result from its use. Specifications subject to change without notice. No license is granted by implication or otherwise under any patent or patent rights of Analog Devices. Trademarks and registered trademarks are the property of their respective owners.

TABLE OF CONTENTS

Features	1	Reading Sensor Data	9
Applications	1	Device Configuration	9
Functional Block Diagram	1	Burst Mode Data Collection	9
General Description	1	Output Data Registers	11
Specifications	3	Calibration	11
Timing Specifications	5	Operational Control	12
Timing Diagrams	5	Input/Output Functions	13
Absolute Maximum Ratings	6	Diagnostics	14
ESD Caution	6	Outline Dimensions	16
Pin Configuration and Function Descriptions	7	Ordering Guide	16
Typical Performance Characteristics	8		
Basic Operation	9		

SPECIFICATIONS

T_A = -40°C to +85°C, VCC = 5.0 V, angular rate = 0°/sec, dynamic range = ±300°/sec, ±1 g, unless otherwise noted.

Table 1.

Parameter	Test Conditions	Min	Typ	Max	Unit
GYROSCOPES					
Dynamic Range		±300	±375		°/sec
Initial Sensitivity	T _A = 25°C, dynamic range = ±300°/sec	0.0495	0.05	0.0505	°/sec/LSB
	T _A = 25°C, dynamic range = ±150°/sec		0.025		°/sec/LSB
	T _A = 25°C, dynamic range = ±75°/sec		0.0125		°/sec/LSB
Sensitivity Temperature Coefficient			40		ppm/°C
Misalignment	Reference to z-axis accelerometer, T _A = 25°C		0.05		Degrees
	Axis-to-frame (package), T _A = 25°C		±0.5		Degrees
Nonlinearity	Best fit straight line		0.1		% of FS
Initial Bias Error	T _A = 25°C, ±1 σ		±3		°/sec
In-Run Bias Stability	T _A = 25°C, 1 σ, SMPL_PRD = 0x01		0.007		°/sec
Angular Random Walk	T _A = 25°C, 1 σ, SMPL_PRD = 0x01		1.9		°/√hr
Bias Temperature Coefficient			0.1		°/sec/°C
Linear Acceleration Effect on Bias	Any axis, 1 σ (MSC_CTRL, Bit 7 = 1)		0.05		°/sec/g
Bias Voltage Sensitivity	VCC = 4.75 V to 5.25 V		0.25		°/sec/V
Output Noise	T _A = 25°C, ±300°/sec range, no filtering		0.9		°/sec rms
Rate Noise Density	T _A = 25°C, f = 25 Hz, ±300°/sec, no filtering		0.038		°/sec/√Hz rms
3 dB Bandwidth			330		Hz
Sensor Resonant Frequency			14.5		kHz
Self-Test Change in Output Response	±300°/sec range setting	±696	±1400	±2449	LSB
ACCELEROMETERS					
Dynamic Range	Each axis	±5			g
Initial Sensitivity	25°C		1		mg/LSB
Initial Sensitivity Tolerance			±1		%
Sensitivity Temperature Coefficient			50		ppm/°C
Misalignment	Axis-to-axis, T _A = 25°C, Δ = 90° ideal		±0.25		Degrees
	Axis-to-frame (package), T _A = 25°C		±0.5		Degrees
Nonlinearity	Best fit straight line		±0.3		% of FS
Initial Bias Error	T _A = 25°C, ±1 σ		±15		mg
In-Run Bias Stability	T _A = 25°C, 1 σ		0.2		mg
Velocity Random Walk	T _A = 25°C, 1 σ		0.35		m/sec/√hr
Bias Temperature Coefficient			0.3		mg/°C
Bias Voltage Sensitivity			2.5		mg/V
Output Noise	T _A = 25°C, no filtering		9		mg rms
Noise Density	T _A = 25°C, no filtering		0.4		mg/√Hz rms
3 dB Bandwidth			330		Hz
Sensor Resonant Frequency			5.5		kHz
Self-Test Change in Output Response	X-axis and y-axis	60		180	LSB
TEMPERATURE SENSOR					
Scale Factor	T _A = 25°C output = 0x0000		0.14		°C/LSB
ADC INPUT					
Resolution			12		Bits
Integral Nonlinearity			±2		LSB
Differential Nonlinearity			±1		LSB
Offset Error			±4		LSB
Gain Error			±2		LSB
Input Range		0		+3.3	V
Input Capacitance	During acquisition		20		pF

Parameter	Test Conditions	Min	Typ	Max	Unit
DAC OUTPUT	5 k Ω /100 pF to GND				
Resolution			12		Bits
Relative Accuracy	For Code 101 to Code 4095		± 4		LSB
Differential Nonlinearity			± 1		LSB
Offset Error			± 5		mV
Gain Error			± 0.5		%
Output Range		0		+3.3	V
Output Impedance			2		Ω
Output Settling Time			10		μ s
LOGIC INPUTS ¹					
Input High Voltage, V _{INH}		2.0			V
Input Low Voltage, V _{INL}				0.8	V
$\overline{\text{CS}}$ Wake-Up Pulse Width	$\overline{\text{CS}}$ signal to wake up from sleep mode			0.55	V
Logic 1 Input Current, I _{INH}	V _{IH} = 3.3 V		± 0.2	± 10	μ A
Logic 0 Input Current, I _{INL}	V _{IL} = 0 V				
All Pins Except $\overline{\text{RST}}$			-40	-60	μ A
$\overline{\text{RST}}$ Pin			-1		mA
Input Capacitance, C _{IN}			10		pF
DIGITAL OUTPUTS ¹					
Output High Voltage, V _{OH}	I _{SOURCE} = 1.6 mA	2.4			V
Output Low Voltage, V _{OL}	I _{SINK} = 1.6 mA			0.4	V
FLASH MEMORY					
Data Retention ³	Endurance ² T _J = 85°C	10,000 20			Cycles Years
FUNCTIONAL TIMES ⁴	Time until data is available				
Power-On Start-up Time	Normal mode, SMPL_PRD \leq 0x09		180		ms
	Low power mode, SMPL_PRD \geq 0x0A		250		ms
Reset Recovery Time	Normal mode, SMPL_PRD \leq 0x09		60		ms
	Low power mode, SMPL_PRD \geq 0x0A		130		ms
Sleep Mode Recovery Time	Normal mode, SMPL_PRD \leq 0x09		4		ms
	Low power mode, SMPL_PRD \geq 0x0A		9		ms
Flash Memory Test Time	Normal mode, SMPL_PRD \leq 0x09		17		ms
	Low power mode, SMPL_PRD \geq 0x0A		90		ms
Automatic Self-Test Time	SMPL_PRD = 0x01		12		ms
CONVERSION RATE	SMPL_PRD = 0x01 to 0xFF	0.413		819.2	SPS
Clock Accuracy				± 3	%
Sync Input Clock				1.2	kHz
POWER SUPPLY					
Power Supply Current	Operating voltage range, VCC	4.75	5.0	5.25	V
	Low power mode at 25°C		24		mA
	Normal mode at 25°C		49		mA
	Sleep mode at 25°C		500		μ A

¹ The digital I/O signals are driven by an internal 3.3 V supply, and the inputs are 5 V tolerant.

² Endurance is qualified as per JEDEC Standard 22, Method A117, and measured at -40°C, +25°C, +85°C, and +125°C.

³ The retention lifetime equivalent is at a junction temperature (T_J) of 85°C as per JEDEC Standard 22, Method A117. Retention lifetime decreases with junction temperature.

⁴ These times do not include thermal settling and internal filter response times (330 Hz bandwidth), which may impact overall accuracy.

TIMING SPECIFICATIONS

T_A = 25°C, VCC = 5 V, unless otherwise noted.

Table 2.

Parameter	Description	Normal Mode (SMPL_PRD ≤ 0x09)			Low Power Mode (SMPL_PRD ≥ 0x0A)			Burst Mode			Unit
		Min ¹	Typ	Max	Min ¹	Typ	Max	Min ¹	Typ	Max	
f _{SCLK}		0.01		2.0	0.01		0.3	0.01		1.0	MHz
t _{STALL}	Stall period between data	9			75			1/f _{SCLK}			μs
t _{READRATE}	Read rate	40			100						μs
t _{CS}	Chip select to clock edge	48.8			48.8			48.8			ns
t _{DAV}	DOUT valid after SCLK edge			100			100			100	ns
t _{DSU}	DIN setup time before SCLK rising edge	24.4			24.4			24.4			ns
t _{DHD}	DIN hold time after SCLK rising edge	48.8			48.8			48.8			ns
t _{SCLKR} , t _{SCLKF}	SCLK rise/fall times		5	12.5		5	12.5		5	12.5	ns
t _{DF} , t _{DR}	DOUT rise/fall times		5	12.5		5	12.5		5	12.5	ns
t _{SFS}	\overline{CS} high after SCLK edge	5			5			5			ns
t ₁	Input sync pulse width		5								μs
t ₂	Input sync to data ready output		600								μs
t ₃	Input sync period	833									μs

¹Guaranteed by design and characterization, but not tested in production.

TIMING DIAGRAMS

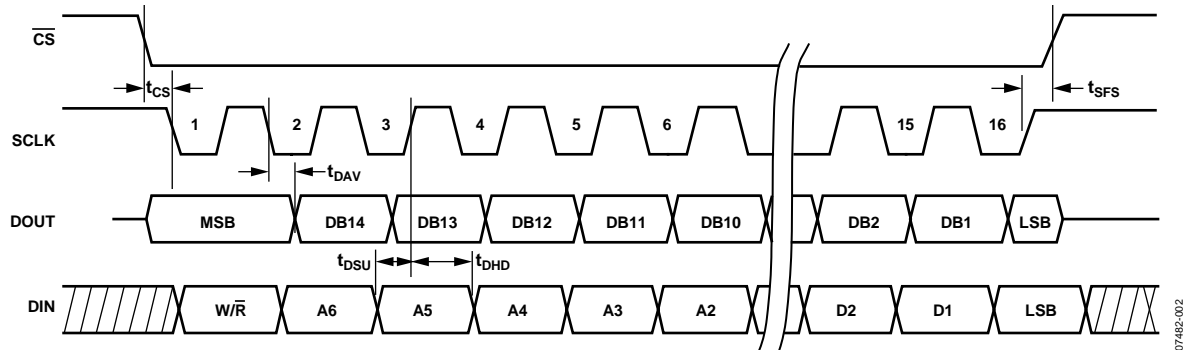

Figure 2. SPI Timing and Sequence

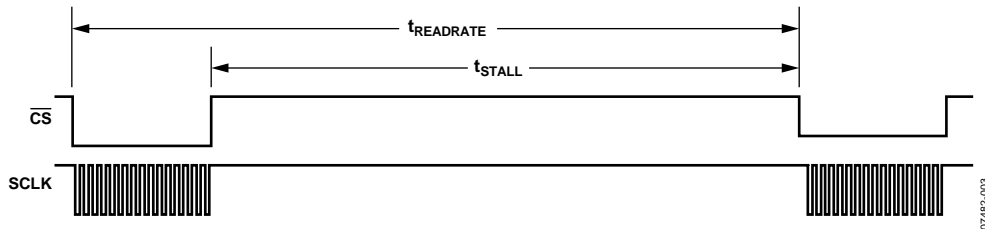

Figure 3. Stall Time and Data Rate

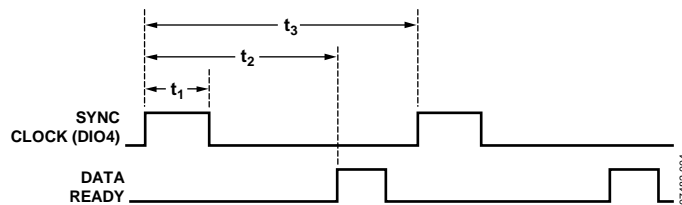

Figure 4. Input Clock Timing Diagram

ABSOLUTE MAXIMUM RATINGS

Table 3.

Parameter	Rating
Acceleration	
Any Axis, Unpowered	2000 <i>g</i>
Any Axis, Powered	2000 <i>g</i>
VCC to GND	−0.3 V to +6.0 V
Digital Input Voltage to GND	−0.3 V to +5.3 V
Digital Output Voltage to GND	−0.3 V to VCC + 0.3 V
Analog Input to GND	−0.3 V to +3.6 V
Operating Temperature Range	−40°C to +105°C
Storage Temperature Range	−65°C to +125°C ^{1,2}

¹ Extended exposure to temperatures outside the specified temperature range of −40°C to +85°C can adversely affect the accuracy of the factory calibration. For best accuracy, store the parts within the specified operating range of −40°C to +85°C.

² Although the device is capable of withstanding short-term exposure to 150°C, long-term exposure threatens internal mechanical integrity.

Stresses above those listed under Absolute Maximum Ratings may cause permanent damage to the device. This is a stress rating only; functional operation of the device at these or any other conditions above those indicated in the operational section of this specification is not implied. Exposure to absolute maximum rating conditions for extended periods may affect device reliability.

Table 4. Package Characteristics

Package Type	θ_{JA}	θ_{JC}	Device Weight
24-Lead Module	39.8°C/W	14.2°C/W	16 grams

ESD CAUTION



ESD (electrostatic discharge) sensitive device. Charged devices and circuit boards can discharge without detection. Although this product features patented or proprietary protection circuitry, damage may occur on devices subjected to high energy ESD. Therefore, proper ESD precautions should be taken to avoid performance degradation or loss of functionality.

PIN CONFIGURATION AND FUNCTION DESCRIPTIONS

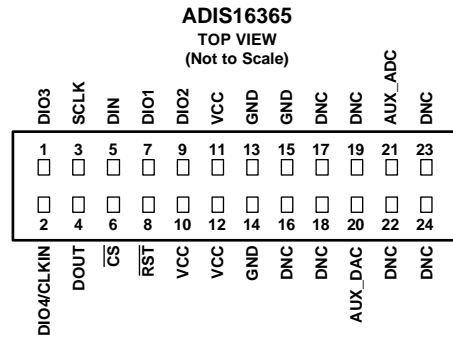

- NOTES**
1. CONNECTOR PINS ARE NOT VISIBLE FROM THE TOP VIEW.
 2. THIS REPRESENTATION DISPLAYS THE TOP VIEW PINOUT FOR THE MATING SOCKET CONNECTOR.
 3. DNC = DO NOT CONNECT.

07570-005

Figure 5. Pin Configuration

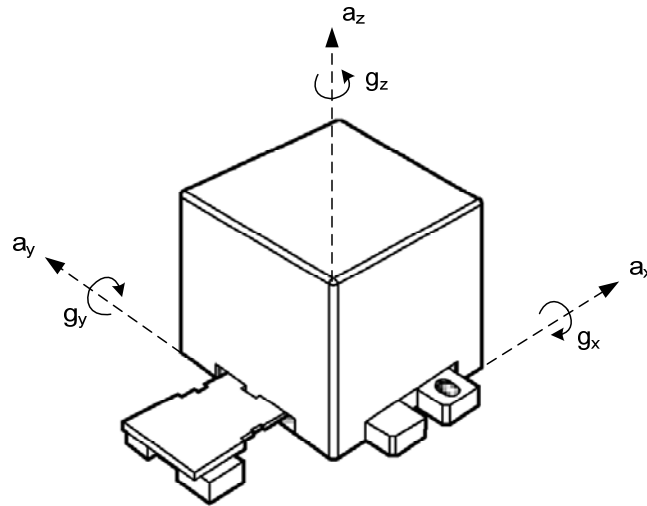

Figure 6. Axial Orientation

Table 5. Pin Function Descriptions

Pin No.	Mnemonic	Type ¹	Description
1	DIO3	I/O	Configurable Digital Input/Output.
2	DIO4/CLKIN	I/O	Configurable Digital Input/Output or Sync Clock Input.
16, 17, 18, 19, 22, 23, 24	DNC	N/A	Do Not Connect.
3	SCLK	I	SPI Serial Clock.
4	DOUT	O	SPI Data Output. Clocks output on SCLK falling edge.
5	DIN	I	SPI Data Input. Clocks input on SCLK rising edge.
6	\overline{CS}	I	SPI Chip Select.
7	DIO1	I/O	Configurable Digital Input/Output.
8	\overline{RST}	I	Reset.
9	DIO2	I/O	Configurable Digital Input/Output.
10, 11, 12	VCC	S	Power Supply.
13, 14, 15	GND	S	Power Ground.
20	AUX_DAC	O	Auxiliary, 12-Bit DAC Output.
21	AUX_ADC	I	Auxiliary, 12-Bit ADC Input.

¹ S is supply, O is output, I is input, N/A is not applicable.

TYPICAL PERFORMANCE CHARACTERISTICS

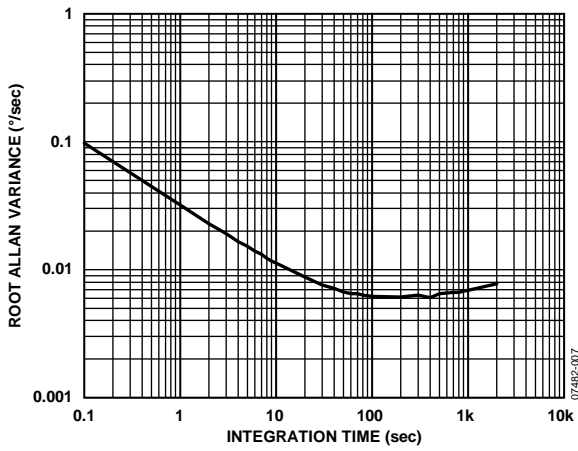

Figure 7. Gyroscope Allan Variance

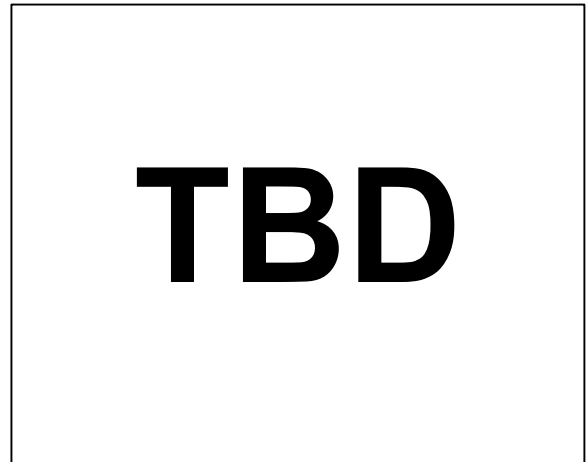

Figure 8. Accelerometer Allan Variance

BASIC OPERATION

The ADIS16364 is an autonomous sensor system that starts up after it has a valid power supply voltage and begins producing inertial measurement data at a sample rate of 819.2 SPS. After each sample cycle, the sensor data loads into the output registers and DIO1 pulses, providing a new data ready control signal for driving system-level interrupt service routines. In a typical system, a master processor accesses the output data registers through the SPI interface, using the hook-up shown in Figure 9. Table 6 provides a generic, functional description for each pin on the master processor. Table 7 describes the typical master processor settings normally found in a configuration register and used for communicating with the ADIS16364.

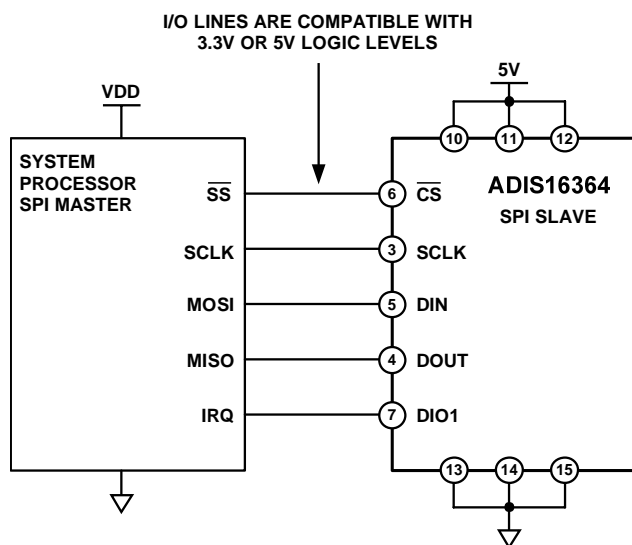

Figure 9. Electrical Hook-Up Diagram

Table 6. Generic Master Processor Pin Names and Functions

Pin Name	Function
\overline{SS}	Slave select
IRQ	Interrupt request
MOSI	Master output, slave input
MISO	Master input, slave output
SCLK	Serial clock

Table 7. Generic Master Processor SPI Settings

Processor Setting	Description
Master	The ADIS16364 operates as a slave.
SCLK Rate ≤ 2 MHz ¹	Normal mode, SMPL_PRD[7:0] $\leq 0x08$.
CPOL = 1	Clock polarity.
CPHA = 1	Clock phase.
MSB-First	Bit sequence.
16-Bit	Shift register/data length.

¹ For burst mode, SCLK rate ≤ 1 MHz. For low power mode, SCLK rate ≤ 300 kHz.

The user registers provide addressing for all input/output operations on the SPI interface. Each 16-bit register has two 7-bit addresses: one for its upper byte and one for its lower byte.

Table 8 provides the lower byte address for each register, and Figure 10 provides the generic bit assignments.

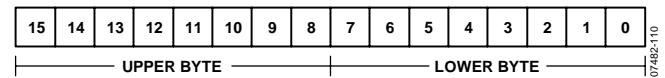

Figure 10. Output Register Bit Assignments

READING SENSOR DATA

Although the ADIS16364 produces data independently, it operates as a SPI slave device, which communicates with system (master) processors using the 16-bit segments displayed in Figure 11. Individual register reads require two 16-bit sequences. The first 16-bit sequence provides the read command bit (R/W = 0) and the target register address (A6 ... A0). The second sequence transmits the register contents (D15 ... D0) on the DOUT line. For example, if DIN = 0x0A00, then the content of XACCL_OUT shifts out on the DOUT line during the next 16-bit sequence.

The SPI operates in full duplex mode, which means that the master processor can read the output data from DOUT while using the same SCLK pulses to transmit the next target address on DIN.

DEVICE CONFIGURATION

The user register memory map (see Table 8) identifies configuration registers with either a W or R/W. Configuration commands also use the bit sequence displayed in Figure 12. If the MSB is equal to 1, the last eight bits (DC7 ... DC0) in the DIN sequence load into the memory address associated with the address bits (A5 ... A0). For example, if the DIN = 0xA11F, then 0x1F loads into Address Location 0x26 (ALM_MAG1, upper byte) at the conclusion of the data frame.

Most of the registers have a backup location in nonvolatile flash memory. The master processor must manage the backup function. Set GLOB_CMD[3] = 1 (DIN = 0xBE01) to execute a manual flash update (backup) operation, which copies the user registers into their respective flash memory locations. This operation takes 50 ms and requires the power supply voltage to be within the specified limit to complete properly. The FLASH_CNT register provides a running count of these events for managing the long-term reliability of the flash memory.

BURST MODE DATA COLLECTION

Burst mode data collection offers a more process-efficient method for collecting data from the ADIS16364. In 10 sequential data cycles (each separated by one SCLK period), all nine output registers clock out on DOUT. This sequence starts when the DIN sequence is 0011 1110 0000 0000 (0x3E00). Next, the contents of each output register are output from DOUT, starting with SUPPLY_OUT and ending with AUX_ADC (see Figure 12). The addressing sequence shown in Table 8 determines the order of the outputs in burst mode.

Table 8. User Register Memory Map

Name	R/W	Flash Backup	Address ¹	Default	Function	Bit Assignments
FLASH_CNT	R	Yes	0x00	N/A	Flash memory write count	N/A
SUPPLY_OUT	R	No	0x02	N/A	Power supply measurement	Table 9
XGYRO_OUT	R	No	0x04	N/A	X-axis gyroscope output	Table 9
YGYRO_OUT	R	No	0x06	N/A	Y-axis gyroscope output	Table 9
ZGYRO_OUT	R	No	0x08	N/A	Z-axis gyroscope output	Table 9
XACCL_OUT	R	No	0x0A	N/A	X-axis accelerometer output	Table 9
YACCL_OUT	R	No	0x0C	N/A	Y-axis accelerometer output	Table 9
ZACCL_OUT	R	No	0x0E	N/A	Z-axis accelerometer output	Table 9
XTEMP_OUT	R	No	0x10	N/A	X-axis gyroscope temperature measurement	Table 9
YTEMP_OUT	R	No	0x12	N/A	Y-axis gyroscope temperature measurement	Table 9
ZTEMP_OUT	R	No	0x14	N/A	Z-axis gyroscope temperature measurement	Table 9
AUX_ADC	R	No	0x16	N/A	Auxiliary ADC output	Table 9
N/A	N/A	N/A	0x18	N/A	Reserved	N/A
XXGYRO_OFF	R/W	Yes	0x1A	0x0000	X-axis gyroscope bias offset factor	Table 10
YXGYRO_OFF	R/W	Yes	0x1C	0x0000	Y-axis gyroscope bias offset factor	Table 10
ZXGYRO_OFF	R/W	Yes	0x1E	0x0000	Z-axis gyroscope bias offset factor	Table 10
XACCL_OFF	R/W	Yes	0x20	0x0000	X-axis acceleration bias offset factor	Table 11
YACCL_OFF	R/W	Yes	0x22	0x0000	Y-axis acceleration bias offset factor	Table 11
ZACCL_OFF	R/W	Yes	0x24	0x0000	Z-axis acceleration bias offset factor	Table 11
ALM_MAG1	R/W	Yes	0x26	0x0000	Alarm 1 amplitude threshold	Table 22
ALM_MAG2	R/W	Yes	0x28	0x0000	Alarm 2 amplitude threshold	Table 22
ALM_SMPL1	R/W	Yes	0x2A	0x0000	Alarm 1 sample size	Table 23
ALM_SMPL2	R/W	Yes	0x2C	0x0000	Alarm 2 sample size	Table 23
ALM_CTRL	R/W	Yes	0x2E	0x0000	Alarm control	Table 24
AUX_DAC	R/W	No	0x30	0x0000	Auxiliary DAC data	Table 18
GPIO_CTRL	R/W	No	0x32	0x0000	Auxiliary digital input/output control	Table 16
MSC_CTRL	R/W	Yes	0x34	0x0006	Miscellaneous control	Table 17
SMPL_PRD	R/W	Yes	0x36	0x0001	Internal sample period (rate) control	Table 13
SENS_AVG	R/W	Yes	0x38	0x0402	Dynamic range/digital filter control	Table 15
SLP_CNT	W	No	0x3A	0x0000	Sleep mode control	Table 14
DIAG_STAT	R	No	0x3C	0x0000	System status	Table 21
GLOB_CMD	W	N/A	0x3E	0x0000	System command	Table 12

¹ Each register contains two bytes. The address of the lower byte is displayed. The address of the upper byte is equal to the address of the lower byte, plus 1.

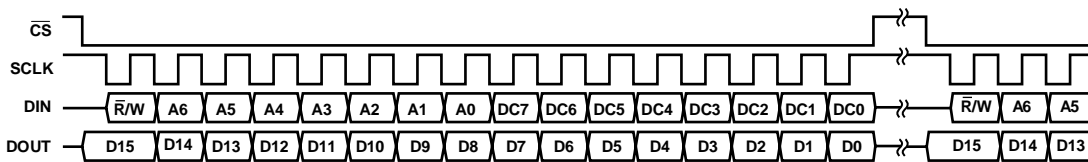

NOTES
1. DOUT BITS ARE BASED ON THE PREVIOUS 16-BIT SEQUENCE ($\bar{R} = 0$).

Figure 11. Output Register Bit Assignments

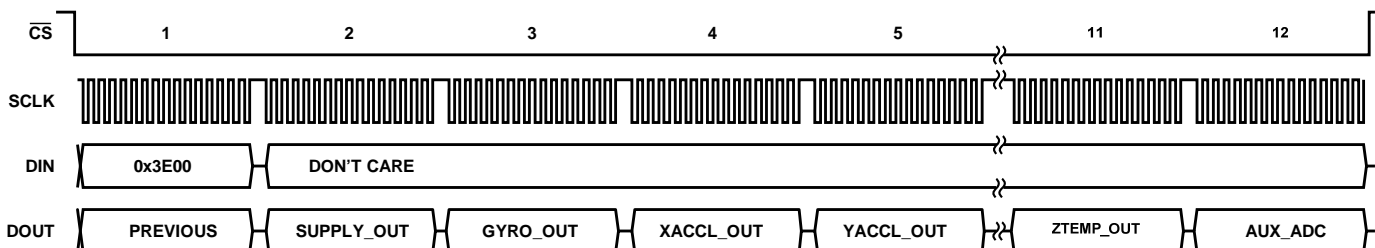

Figure 12. Burst Mode Read Sequence

OUTPUT DATA REGISTERS

Figure 6 provides the positive measurement direction for each inertial sensor (gyroscope and accelerometers). Table 9 provides the configuration and scale factor for each output data register in the ADIS16364. All inertial sensor outputs are 14 bits in length and are in twos complement format, which means that 0x0000 is equal to 0 LSB, 0x0001 is equal to +1 LSB, and 0x3FFF is equal to -1 LSB. The following is an example of how to calculate the sensor measurement from the XGYRO_OUT:

$$\begin{aligned} XGYRO_OUT &= 0x3B4A \\ 0x000 - 0x33B4A &= -0x04B6 = -(4 \times 256 + 11 \times 16 + 6) \\ -0x04B6 &= -1206 \text{ LSB} \\ \text{Rate} &= 0.05^\circ/\text{sec} \times (-1206) = -60.3^\circ/\text{sec} \end{aligned}$$

Therefore, an XGYRO_OUT output of 0x3B4A corresponds to a clockwise rotation about the z-axis (see Figure 6) of 60.3°/sec when looking at the top of the package.

Table 9. Output Data Register Formats

Register	Bits	Format	Scale
SUPPLY_OUT	12	Binary, 5 V = 0x0814	2.42 mV
XGYRO_OUT ¹	14	Twos complement	0.05°/sec
YGYRO_OUT ¹	14	Twos complement	0.05°/sec
ZGYRO_OUT ¹	14	Twos complement	0.05°/sec
XACCL_OUT	14	Twos complement	1 mg
YACCL_OUT	14	Twos complement	1 mg
ZACCL_OUT	14	Twos complement	1 mg
XTEMP_OUT ²	12	Twos complement	0.14°C
YTEMP_OUT ²	12	Twos complement	0.14°C
ZTEMP_OUT ²	12	Twos complement	0.14°C
AUX_ADC	12	Binary, 1 V = 0x04D9	0.81 mV

¹ Assumes that the scaling is set to ± 300°/sec. This factor scales with the range.
² Note that typically, +25°C, these registers read 0x0000.

Each output data register uses the bit assignments shown in Figure 13. The ND flag indicates that unread data resides in the output data registers. This flag clears and returns to 0 during an output register read sequence. It returns to 1 after the next internal sample updates the registers with new data. The EA flag indicates that one of the error flags in the DIAG_STAT register (see Table 21) is active (true). The remaining 14 bits are for data.

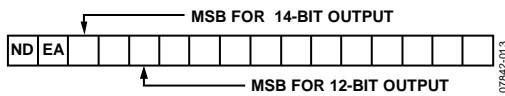

Figure 13. Output Register Bit Assignments

Auxiliary ADC

The AUX_ADC register provides access to the auxiliary ADC input channel. The ADC is a 12-bit successive approximation converter, which has an equivalent input circuit to the one in Figure 14. The maximum input range is +3.3 V. The ESD protection diodes can handle 10 mA without causing irreversible damage. The switch on-resistance (R1) has a typical value of 100 Ω. The sampling capacitor, C2, has a typical value of 16 pF.

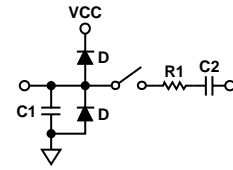

Figure 14. Equivalent Analog Input Circuit (Conversion Phase: Switch Open, Track Phase: Switch Closed)

CALIBRATION

Manual Bias Calibration

The bias offset registers in Table 10 and Table 11 provide a manual adjustment function for the output of each sensor. For example, if XGYRO_OFF equals 0x1FF6, the XGYRO_OUT offset shifts by -10 LSBs, or -0.125°/sec. The DIN command for the upper byte is DIN = 0x9B1F; for the lower byte, DIN = 0x9AF6.

Table 10. XGYRO_OFF, YGYRO_OFF, ZGYRO_OFF

Bits	Description
[15:13]	Not used.
[12:0]	Data bits. Twos complement, 0.0125°/sec per LSB. Typical adjustment range = ±50°/sec.

Table 11. XACCL_OFF, YACCL_OFF, ZACCL_OFF

Bits	Description
[15:12]	Not used.
[11:0]	Data bits, twos complement 1 mg/LSB. Typical adjustment range = ±2 g.

Gyroscope Automatic Bias Null Calibration

Set GLOB_CMD[0] = 1 (DIN = 0xBE01) to execute this function, which measures XGYRO_OUT and then loads XGYRO_OFF with the opposite value to provide a quick bias calibration. Then, all sensor data resets to 0, and the flash memory updates automatically (50 ms). See Table 12.

Gyroscope Precision Automatic Bias Null Calibration

Set GLOB_CMD[4] = 1 (DIN = 0xBE10) to execute this function, which takes the sensor offline for 30 sec while it collects a set of XGYRO_OUT data and calculates a more accurate bias correction factor. Once calculated, the correction factor loads into XGYRO_OFF; all sensor data resets to 0, and the flash memory updates automatically (50 ms). See Table 12.

Restoring Factory Calibration

Set GLOB_CMD[1] = 1 (DIN = 0xBE02) to execute this function, which resets each user calibration register (see Table 10 and Table 11) to 0x0000, resets all sensor data to 0, and automatically updates the flash memory (50 ms). See Table 12.

Linear Acceleration Bias Compensation (Gyroscope)

Set MSC_CTRL[7] = 1 (DIN = 0xB486) to enable correction for low frequency acceleration influences on gyroscope bias. Note that the DIN sequence also preserves the factory default condition for the data ready function (see Table 17).

OPERATIONAL CONTROL

Global Commands

The GLOB_CMD register provides trigger bits for several useful functions. Setting the assigned bit to 1 starts each operation, which returns to the bit to 0 after completion. For example, set GLOB_CMD[7] = 1 (DIN = 0xBE80) to execute a software reset, which stops the sensor operation and runs the device through its start-up sequence. This includes loading the control registers with their respective flash memory locations prior to producing new data. Reading the GLOB_CMD registers (DIN = 0x3E00) starts the burst mode read sequence.

Table 12. GLOB_CMD

Bits	Description
[15:8]	Not used
[7]	Software reset command
[6:5]	Not used
[4]	Precision autonull command
[3]	Flash update command
[2]	Auxiliary DAC data latch
[1]	Factory calibration restore command
[0]	Autonull command

Internal Sample Rate

The ADIS16364 performs best when the sample rate is set to the factory default setting of 819.2 SPS. For applications that value lower sample rates, the SMPL_PRD register controls the ADIS16364 internal sample (see Table 13), and the following relationship produces the sample rate:

$$t_s = t_B \times N_s + 1$$

Table 13. SMPL_PRD

Bit	Description
[15:8]	Not used
[7]	Time base (t_b) 0 = 0.61035 ms, 1 = 18.921 ms
[6:0]	Increment setting (N_s) Internal sample period = $t_s = t_B \times N_s + 1$

For example, set SMPL_PRD[7:0] = 0x0A (DIN = 0xB60A) for an internal sample period of 6.7 ms (sample rate = 149 SPS). For systems that value lower sample rates, in-system characterization can help determine performance trade-offs.

Power Management

Setting SMPL_PRD \geq 0x0A also sets the sensor in low power mode. In addition to sensor performance, this mode also affects SPI data rates (see Table 2). Two sleep mode options are listed in Table 14. Set SLP_CNT[8] = 1 (DIN = 0xBB01) to start the indefinite sleep mode, which requires \overline{CS} assertion (high to low), reset, or power cycle to wake-up. Set SLP_CNT[7:0] = 0x64 (DIN = 0xBA64) to put the ADIS16364 to sleep for 100 sec, as an example of the programmable sleep time option.

Table 14. SLP_CNT

Bit	Description
[15:9]	Not used
[8]	Indefinite sleep mode, set to 1
[7:0]	Programmable time bits, 0.5 sec/LSB

Digital Filtering

A programmable low-pass filtering provides additional opportunity for noise reduction on the inertial sensor outputs. This filter contains two cascaded averaging filters that provide a Bartlett window, FIR filter response (see Figure 15). SENS_AVG[2:0] controls the number of taps in each averaging stage. For example, SENS_AVG[2:0] = 110 sets each stage tap to 64.

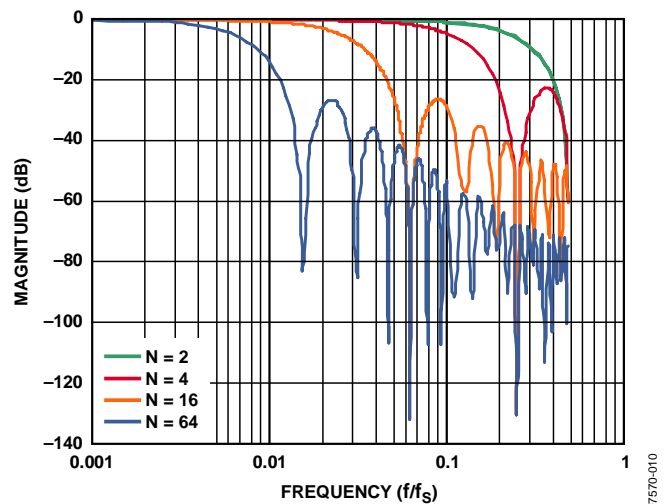

Figure 15. Bartlett Window FIR Frequency Response (Phase = M Samples)

Dynamic Range

There are three dynamic range settings for the gyroscope: $\pm 75^\circ/\text{sec}$, $\pm 150^\circ/\text{sec}$, and $\pm 300^\circ/\text{sec}$. The lower dynamic range settings ($\pm 75^\circ/\text{sec}$ and $\pm 150^\circ/\text{sec}$) limit the minimum filter tap sizes to maintain the resolution as the measurement range decreases. The recommended order for programming the SENS_AVG register is upper byte (sensitivity), followed by lower byte (filtering). For example, set SENS_AVG[10:8] = 010 (DIN = 0xB902) for a measurement range to $\pm 150^\circ/\text{sec}$.

Table 15. SENS_AVG

Bits	Value	Description
[15:11]		Not used
[10:8]	100	Measurement range (sensitivity) selection $\pm 300^\circ/\text{sec}$ (default condition)
	010	$\pm 150^\circ/\text{sec}$, filter taps ≥ 4 (Bits[2:0] \geq 0x02)
	001	$\pm 75^\circ/\text{sec}$, filter taps ≥ 16 (Bits[2:0] \geq 0x04)
[7:3]		Not used
[2:0]		Number of taps in each stage $N = 2^M$

INPUT/OUTPUT FUNCTIONS

General-Purpose I/O

DIO1, DIO2, DIO3, and DIO4 are configurable, general-purpose I/O lines that serve multiple purposes according to the following control register priority: MSC_CTRL, ALM_CTRL, and GPIO_CTRL. For example, set GPIO_CTRL = 0x080C (DIN = 0xB508, then 0xB40C) to set DIO1 and DIO2 as inputs and DIO3 and DIO4 as outputs, with DIO3 set low and DIO4 set high.

Table 16. GPIO_CTRL

Bit	Description
[15:12]	Not used
[11]	General-Purpose I/O Line 4 (DIO4) data level
[10]	General-Purpose I/O Line 3 (DIO3) data level
[9]	General-Purpose I/O Line 2 (DIO2) data level
[8]	General-Purpose I/O Line 1 (DIO1) data level
[7:4]	Not used
[3]	General-Purpose I/O Line 4 (DIO4), direction control 1 = output, 0 = input
[2]	General-Purpose I/O Line 3 (DIO3), direction control 1 = output, 0 = input
[1]	General-Purpose I/O Line 2 (DIO2), direction control 1 = output, 0 = input
[0]	General-Purpose I/O Line 1 (DIO1), direction control 1 = output, 0 = input

Input Clock Configuration

The input clock configuration function allows for external control over sampling in the ADIS16364. Set GPIO_CTRL[3] = 0 (DIN = 0x0B200) and SMPL_PRD[7:0] = 0x00 (DIN = 0xB600) to enable this function. See Table 2 and Figure 4 for timing information.

Data Ready I/O Indicator

The factory default sets DIO1 as a positive data ready indicator signal. The MSC_CTRL[2:0] register provides configuration options for changing this. For example, set MSC_CTRL[2:0] = 100 (DIN = 0xB404) to change the polarity of the data ready signal for interrupt inputs that require negative logic inputs for activation. The pulse width will be between 100 μs and 200 μs over all conditions.

Table 17. MSC_CTRL

Bits	Description
[15:12]	Not used
[11]	Memory test (clears on completion) 1 = enabled, 0 = disabled
[10]	Internal self-test enable (clears on completion) 1 = enabled, 0 = disabled
[9]	Manual self-test, negative stimulus 1 = enabled, 0 = disabled
[8]	Manual self-test, positive stimulus 1 = enabled, 0 = disabled
[7]	Linear acceleration bias compensation for gyroscopes 1 = enabled, 0 = disabled
[6]	Linear accelerometer origin alignment 1 = enabled, 0 = disabled
[5:3]	Not used
[2]	Data ready enable 1 = enabled, 0 = disabled
[1]	Data ready polarity 1 = active high, 0 = active low
[0]	Data ready line select 1 = DIO2, 0 = DIO1

Auxiliary DAC

The 12-bit AUX_DAC line can drive its output to within 5 mV of the ground reference when it is not sinking current. As the output approaches 0 V, the linearity begins to degrade (~100 LSB beginning point). As the sink current increases, the nonlinear range increases. The DAC latch command moves the values of the AUX_DAC register into the DAC input register, enabling both bytes to take effect at the same time.

Table 18. AUX_DAC

Bit	Description
[15:12]	Not used
[11:0]	Data bits, scale factor = 0.8059 mV/code Offset binary format, 0 V = 0 codes

Table 19. Setting AUX_DAC = 1 V

DIN	Description
0xB0D9	AUX_DAC[7:0] = 0xD9 (217 LSB).
0xB104	AUX_DAC[15:8] = 0x04 (1024 LSB).
0xBE04	GLOB_CMD[2] = 1. Move values into the DAC input register, resulting in a 1 V output level.

DIAGNOSTICS

Self-Test

Self-test offers the opportunity to verify the mechanical integrity of each MEMS sensor. It applies an electrostatic force to each sensor element, which results in mechanical displacement that simulates a response to actual motion. Table 1 lists the expected response for each sensor, which provides pass/fail criteria. Set `MSC_CTRL[10] = 1` (`DIN = 0xB504`) to run the internal self-test routine, which exercises all inertial sensors, measures each response, makes pass/fail decisions, and reports them to error flags in the `DIAG_STAT` register. `MSC_CTRL[10]` resets itself to 0 after completing the routine. `MSC_CTRL[9:8]` (`DIN = 0xB502` or `0xB501`) provides manual control over the self-test function. Table 20 gives an example test flow for using this option.

Table 20. Manual Self-Test Example Sequence

DIN	Description
0xB601	<code>SMPL_PRD[7:0] = 0x01</code> , sample rate = 819.2 SPS.
0xB904	<code>SENS_AVG[15:8] = 0x04</code> , gyro range = $\pm 300^\circ/\text{sec}$.
0xB802	<code>SENS_AVG[7:0] = 0x02</code> , 4-tap averaging filter. Delay = 50 ms.
0x0400	Read <code>XGYRO_OUT</code> .
0x0600	Read <code>XACCL_OUT</code> .
0x0800	Read <code>YACCL_OUT</code> .
0x0A00	Read <code>ZACCL_OUT</code> .
0xB502	<code>MSC_CTRL[9] = 1</code> , gyroscope negative self-test. Delay = 50 ms.
0x0400	Read <code>XGYRO_OUT</code> . Determine whether the bias in the gyroscope output changes according to the expectation set in Table 2.
0xB501	<code>MSC_CTRL[9:8] = 01</code> , gyroscope/accelerometer positive self-test. Delay = 50 ms.
0x0400	Read <code>XGYRO_OUT</code> .
0x0600	Read <code>XACCL_OUT</code> .
0x0800	Read <code>YACCL_OUT</code> .
0x0A00	Read <code>ZACCL_OUT</code> . Determine whether the bias in the gyroscope and accelerometers changed according to the expectation set in Table 2.
0xB500	<code>MSC_CTRL[15:8] = 0x00</code> .

Zero motion provides results that are more reliable. The settings in Table 20 are flexible and provide opportunity for optimization around speed and noise influence. For example, lowering the filtering taps decreases delay times but increases the opportunity for noise influence.

Memory Test

Setting `MSC_CTRL[11] = 1` (`DIN = 0xB508`) performs a checksum verification of the flash memory locations. The pass/fail criteria load into the `DIAG_STAT[6]` register.

Status

The error flags provide indicator functions for common system level issues. All of the flags clear (set to 0) after each `DIAG_STAT` register read cycle. If an error condition remains, the error flag returns to 1 during the next sample cycle. `DIAG_STAT[1:0]` does not require a read of this register to return to 0. If the power supply voltage goes back into range, these two flags clear automatically.

Table 21. DIAG_STAT Bit Descriptions

Bit	Description
[15]	Z-axis accelerometer self-test failure (1 = fail, 0 = pass)
[14]	Y-axis accelerometer self-test failure (1 = fail, 0 = pass)
[13]	X-axis accelerometer self-test failure (1 = fail, 0 = pass)
[12]	X-axis gyroscope self-test failure (1 = fail, 0 = pass)
[11]	Y-axis gyroscope self-test failure (1 = fail, 0 = pass)
[10]	Z-axis gyroscope self-test failure (1 = fail, 0 = pass)
[9]	Alarm 2 status (1 = active, 0 = inactive)
[8]	Alarm 1 status (1 = active, 0 = inactive)
[7]	Not used
[6]	Flash test, checksum flag (1 = fail, 0 = pass)
[5]	Self-test diagnostic error flag (1 = fail, 0 = pass)
[4]	Sensor overrange (1 = fail, 0 = pass)
[3]	SPI communications failure (1 = fail, 0 = pass)
[2]	Flash update failed (1 = fail, 0 = pass)
[1]	Power supply above 5.25 V 1 = power supply ≥ 5.25 V, 0 = power supply ≤ 5.25 V
[0]	Power supply below 4.75 V 1 = power supply ≤ 4.75 V, 0 = power supply ≥ 4.75 V

Alarm Registers

The alarm function provides monitoring for two independent conditions. The `ALM_CTRL` register provides control inputs for data source, data filtering (prior to comparison), static comparison, dynamic rate-of-change comparison, and output indicator configurations. The `ALM_MAGx` registers establish the trigger threshold and polarity configurations.

Table 25 gives an example of how to configure a static alarm. The `ALM_SMPLx` registers provide the numbers of samples to use in the dynamic rate-of-change configuration. The period equals the number in the `ALM_SMPLx` register, multiplied by the sample period time, established by the `SMPL_PRD` register. See Table 26 for an example of how to configure the sensor for this type of function.

Table 22. ALM_MAG1, ALM_MAG2

Bit	Description
[15]	Comparison polarity 1 = greater than, 0 = less than
[14]	Not used
[13:0]	Data bits that match the format of the trigger source selection

Table 23. ALM_SMPL1, ALM_SMPL2

Bit	Description
[15:8]	Not used
[7:0]	Data bits: number of samples (both 0x00 and 0x01 = 1)

Table 24. ALM_CTRL Bit Designations

Bits	Value	Description
[15:12]		Alarm 2 source selection
	0000	Disable
	0001	Power supply output
	0010	X-axis gyroscope output
	0011	Y-axis gyroscope output
	0100	Z-axis gyroscope output
	0101	X-axis accelerometer output
	0110	Y-axis accelerometer output
	0111	Z-axis accelerometer output
	1000	Gyroscope temperature output
	1001	X-axis inclinometer output
	1010	Y-axis inclinometer output
	1011	Auxiliary ADC input
[11:8]		Alarm 1 source selection (same as Alarm 2)
[7]		Rate of change (ROC) enable for Alarm 2 1 = rate of change, 0 = static level
[6]		Rate of change (ROC) enable for Alarm 1 1 = rate of change, 0 = static level
[5]		Not used
[4]		Comparison data filter setting ¹ 1 = filtered data, 0 = unfiltered data
[3]		Not used
[2]		Alarm output enable 1 = enabled, 0 = disabled
[1]		Alarm output polarity 1 = active high, 0 = active low
[0]		Alarm output line select 1 = DIO2, 0 = DIO1

¹ Incline outputs always use filtered data in this comparison.

Table 25. Alarm Configuration Example 1

DIN	Description
0xAF55, 0xAE17	ALM_CTRL = 0x5517. Alarm 1 input = XACCL_OUT. Alarm 2 input = XACCL_OUT. Static level comparison, filtered data. DIO2 output indicator, positive polarity.
0xA783, 0xA641	ALM_MAG1 = 0x8341. Alarm 1 is true if XACCL_OUT > 0.5 g.
0xA93C, 0xA8BF	ALM_MAG2 = 0x3CBF. Alarm 2 is true if XACCL_OUT < -0.5 g.

Table 26. Alarm Configuration Example 2

DIN	Description
0xAF76, 0xAE87	ALM_CTRL = 0x7687. Alarm 1 input = ZACCL_OUT. Alarm 2 input = YACCL_OUT. Rate of change comparison, unfiltered data. DIO2 output indicator, positive polarity.
0xB601	SMPL_PRD = 0x0001. Sample rate = 819.2 SPS.
0xAB08	ALM_SMPL1 = 0x0008. Alarm 1 rate of change period = 9.77 ms.
0xAC50	ALM_SMPL2 = 0x0050. Alarm 2 rate of change period = 97.7 ms.
0xA783, 0xA641	ALM_MAG1 = 0x8341. Alarm 1 is true if XACCL_OUT > 0.5 g.
0xA93C, 0xA8BE	ALM_MAG2 = 0x3CBE. Alarm 2 is true if XACCL_OUT < -0.5 g.

OUTLINE DIMENSIONS

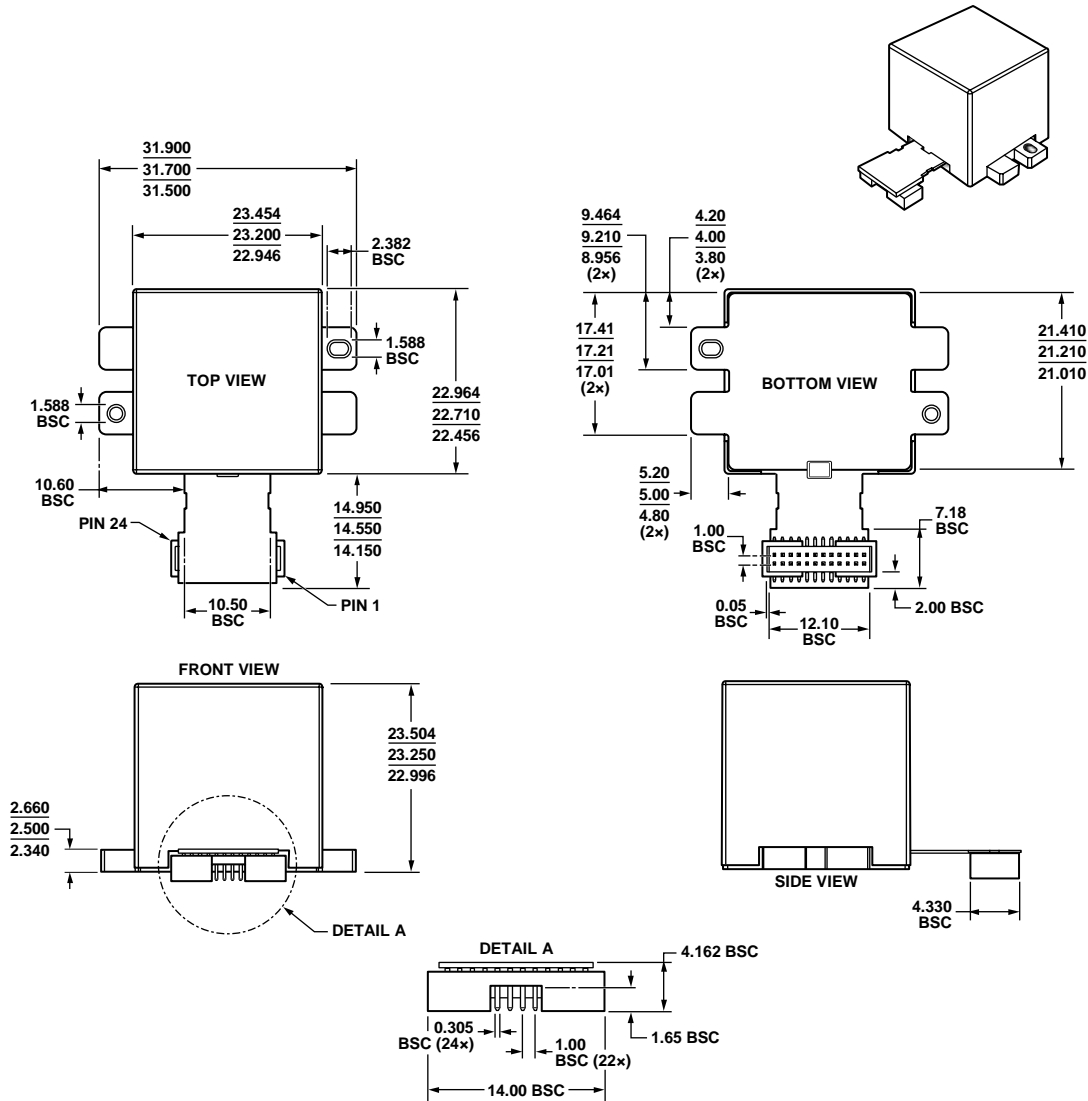

Figure 16. 24-Lead Module with Connector Interface (ML-24-2)
Dimensions shown in millimeters

01108-C

ORDERING GUIDE

Model	Temperature Range	Package Description	Package Option
ADIS16364BMLZ ¹	-40°C to +105°C	24-Lead Module with Connector Interface	ML-24-2
ADIS16364/PCBZ ¹		Interface Board	

¹ Z = RoHS Compliant Part.