

Selectable Adjustable/Fixed Low Dropout 300mA Linear Regulator

Features

- **Wide Operating Voltage: 2.8~6V**
- **Low Dropout Voltage:**
230mV(Typical) @ 300mA
- **Guaranteed 300mA Output Current**
- **Two Modes for Setting Output Voltage**
 - Fixed Output Voltage: 1~5V
 - Adjustable Output Voltage: 0.8~5.5V
- **Current-Limit Protection with Foldback Current**
- **Internal Soft-Start**
- **Over-Temperature Protection**
- **Stable with Low ESR Ceramic Capacitor**
- **SOT-23-5 Package**
- **Lead Free and Green Devices Available (RoHS Compliant)**

Applications

- Cellular Phones
- Portable and Battery-Powered Equipment
- Notebook and Personal Computers

Simplified Application Circuit

1. Fixed Output Voltage Mode

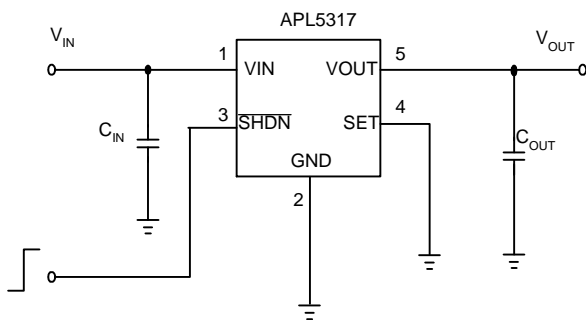

General Description

The APL5317 is a low dropout linear regulator which only needs a single input voltage supply from 2.8 to 6V, and it can deliver current up to 300mA to a set output voltage. It can work with low ESR ceramic capacitors that make it ideal for using in the battery-powered applications, such as notebook computers and cellular phones. Its typical dropout voltage is only 230mV at 300mA loading. The APL5317 provides two output voltage operation modes, the fixed output voltage mode and the adjustable output voltage, controlled by the SET pin for setting the output voltage. The fixed output voltage mode sets the output to a preset voltage (only 1.2V available now) in the chip by connecting SET pin to the ground, and the adjustable output voltage mode needs two resistors as a voltage divider connected to SET pin to define the output. The current-limit with current foldback and thermal shutdown functions protect the device against current over-loads and over temperature. The APL5317 is available in a SOT-23-5 package.

Pin Configuration

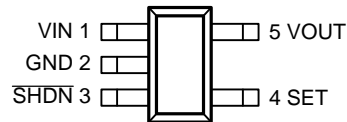

SOT-23-5

2. Adjustable Output Voltage Mode

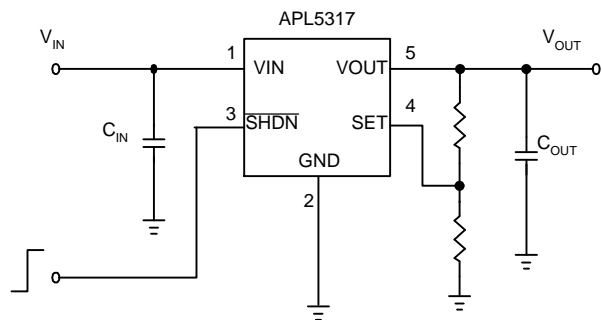

ANPEC reserves the right to make changes to improve reliability or manufacturability without notice, and advise customers to obtain the latest version of relevant information to verify before placing orders.

Ordering and Marking Information

<p>APL5317 □□□□ - □□ □</p> <p>□□□□ — Assembly Material □□ — Handling Code □□ — Temperature Range □□ — Package Code □□ — Voltage Code</p>	<p>Package Code B : SOT-23-5 Operating Junction Temperature Range I : -40 to 85 °C Handling Code TR : Tape & Reel Voltage Code (Note 1) 12 : 1.2V Assembly Material G: Halogen and Lead Free Device</p>
APL5317 B: 375X	X - Date code
APL5317-12 B: 375X	X - Date code

Note : ANPEC lead-free products contain molding compounds/die attach materials and 100% matte tin plate termination finish; which are fully compliant with RoHS. ANPEC lead-free products meet or exceed the lead-free requirements of IPC/JEDEC J-STD-020C for MSL classification at lead-free peak reflow temperature. ANPEC defines “Green” to mean lead-free (RoHS compliant) and halogen free (Br or Cl does not exceed 900ppm by weight in homogeneous material and total of Br and Cl does not exceed 1500ppm by weight).

Note 1: For other voltage versions, please contact ANPEC for details.

Note 2: Because APL5317 and APL5317-12 are identical, the marking of APL5317 is same as APL5317-12.

Absolute Maximum Ratings (Note 3)

Symbol	Parameter	Rating	Unit
V_{IN}	VIN Supply Voltage (VIN to GND)	-0.3 ~ 6.5	V
V_{SHDN}	SHDN Input Voltage (SHDN to GND)	-0.3 ~ 6.5	V
P_D	Power Dissipation	Internally Limited	W
T_J	Junction Temperature	-40 ~ 150	°C
T_{STG}	Storage Temperature	-65 ~ 150	°C
T_{SDR}	Maximum Lead Soldering Temperature, 10 Seconds	260	°C

Note 3: Absolute Maximum Ratings are those values beyond which the life of a device may be impaired. Exposure to absolute maximum rating conditions for extended periods may affect device reliability.

Thermal Characteristics

Symbol	Parameter	Typical Value	Unit
θ_{JA}	Thermal Resistance-Junction to Ambient (Note 4)	240	°C/W
θ_{JC}	Thermal Resistance-Junction to Case	130	°C/W

Note 4 : θ_{JA} is measured with the component mounted on a high effective thermal conductivity test board in free air.

Recommended Operating Conditions

Symbol	Parameter	Range	Unit
V_{IN}	VIN Supply Voltage	2.8 ~ 6	V
V_{OUT}	Output Voltage	0.8 ~ 5.5	V
I_{OUT}	VOU Output Current	0 ~ 300	mA

Recommended Operating Conditions (Cont.)

Symbol	Parameter	Range	Unit
C _{IN}	Input Capacitor	0.22 ~ 100	μF
C _{OUT}	Output Capacitor	1.5 ~ 33	μF
T _J	Junction Temperature	-40 ~ 125	°C

Electrical Characteristics

Unless otherwise specified, these specifications apply over V_{IN} = V_{OUT}+1V (min V_{IN}=2.8V), I_{OUT}=0~300mA, C_{IN} = 1μF, C_{OUT} = 2.2μF, T_A = -40 to 85°C. Typical values are at T_A = 25°C.

Symbol	Parameter	Test Conditions	APL5317			Unit
			Min.	Typ.	Max.	
V _{IN}	Input Voltage		2.8	-	6	V
V _{OUT}	Output Voltage Range		0.8	-	5.5	V
I _Q	Quiescent Current	I _{OUT} =10mA ~300mA	-	135	160	μA
V _{REF}	Reference Voltage	Measured on SET, V _{IN} =V _{OUT} +1V(min V _{IN} =2.8V), I _{OUT} =10mA	-	0.8	-	V
	Output Voltage Accuracy	T _A =25°C, V _{IN} =V _{OUT} +1V(min V _{IN} =2.8V), I _{OUT} =10mA	-1	-	+1	%
	Output Voltage Accuracy	T _A =-40°C ~ 85°C, V _{IN} =V _{OUT} +1V(min V _{IN} =2.8V), I _{OUT} =0~300mA	-2	-	+2	%
V _{DROP}	Dropout Voltage	V _{OUT} = 2.5V, I _{OUT} = 300mA	-	230	360	mV
		V _{OUT} = 3.3V, I _{OUT} = 300mA	-	170	300	
PSRR	Power Supply Ripple Rejection Ratio	f = 10kHz, I _{OUT} = 300mA	-	45	-	dB
	Noise	f = 80Hz to 100kHz, I _{OUT} = 300mA	-	160	-	μV _{RMS}
I _{LIMIT}	Current-Limit		450	600	-	mA
I _{SHORT}	Foldback Current	V _{OUT} = 0V	-	80	-	mA
	SHDN Input Voltage High		1.6	-	-	V
	SHDN Input Voltage Low		-	-	0.4	
	Shutdown VIN Supply Current	SHDN = Low, V _{IN} = 6V	-	0.1	1	μA
	SHDN Pull Low Resistance		-	3	-	MΩ
	V _{OUT} Discharge MOSFET R _{DS(ON)}	SHDN = Low	-	60	-	Ω
	Over Temperature Threshold		-	160	-	°C
	Over Temperature Hysteresis		-	40	-	°C
	SET Input Threshold for Fixed/Adjustable Output Voltage Mode		-	100	-	mV
	SET Input Bias Current	V _{SET} =0.8V	-100	-	100	nA
T _{SS}	Soft-Start Interval		-	60	-	μs

Typical Operating Characteristics

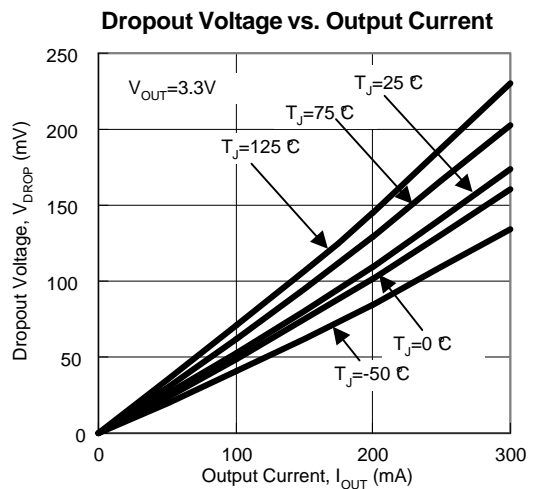
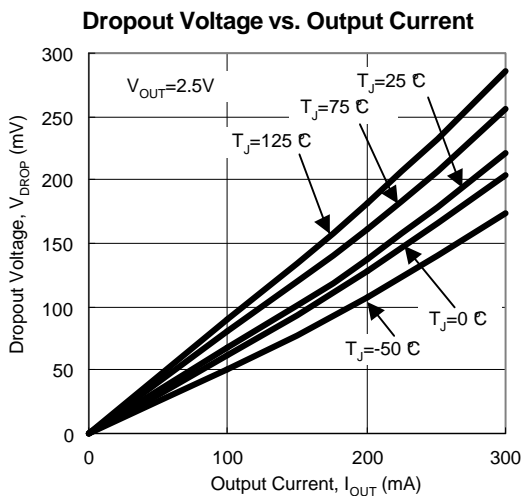
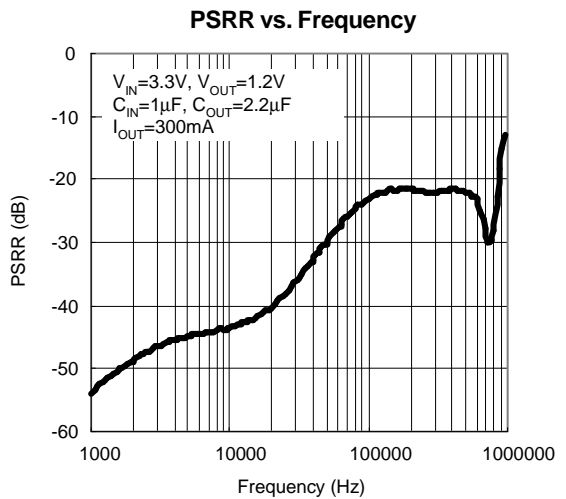
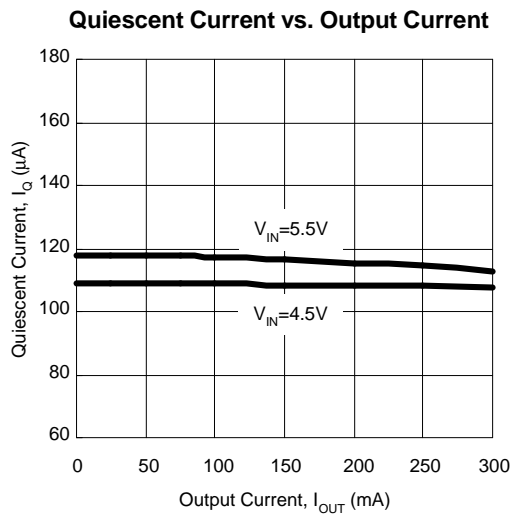
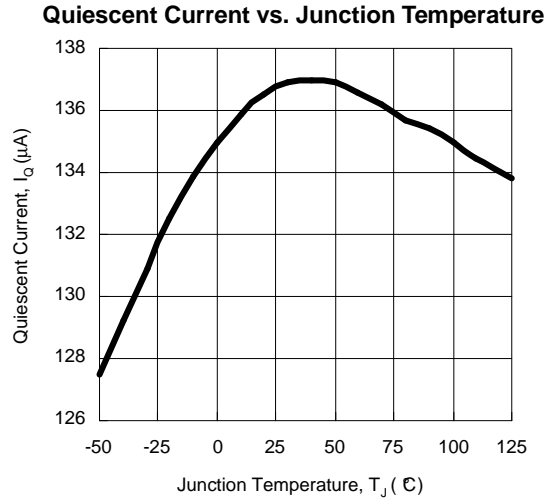
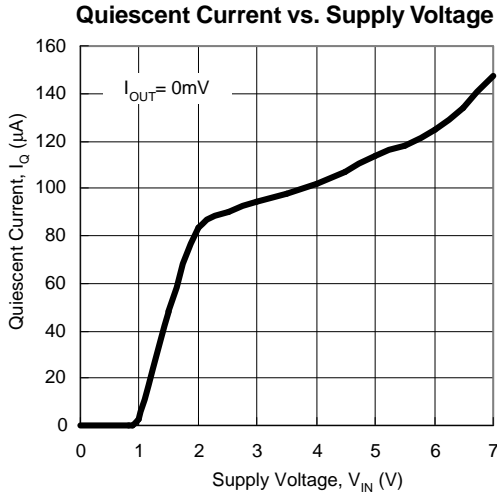

Typical Operating Characteristics (Cont.)

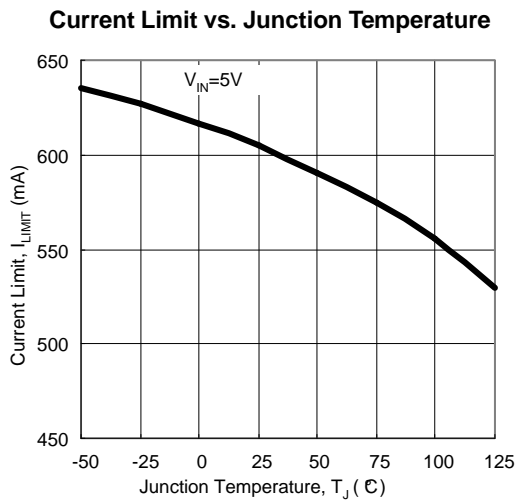
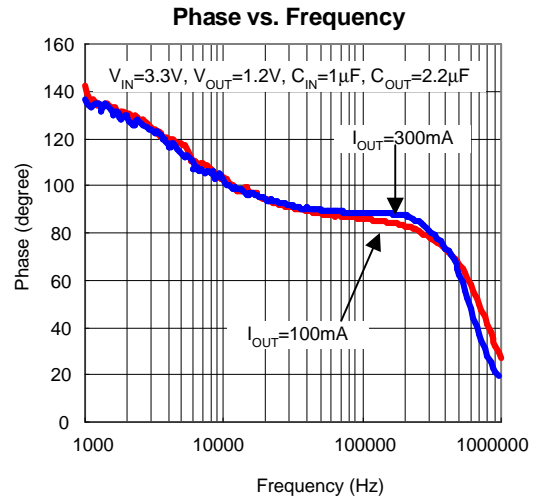
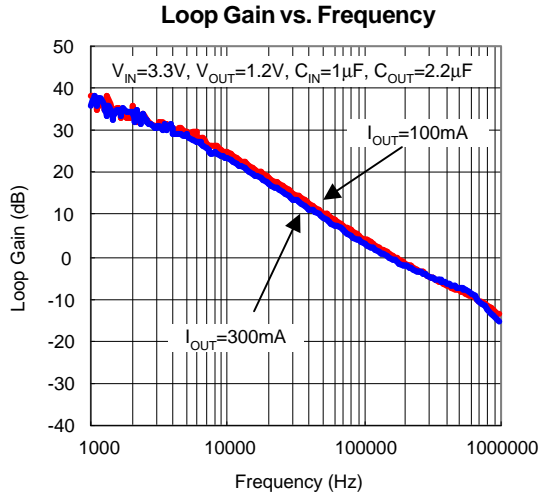

Operating Waveforms

Load Transient

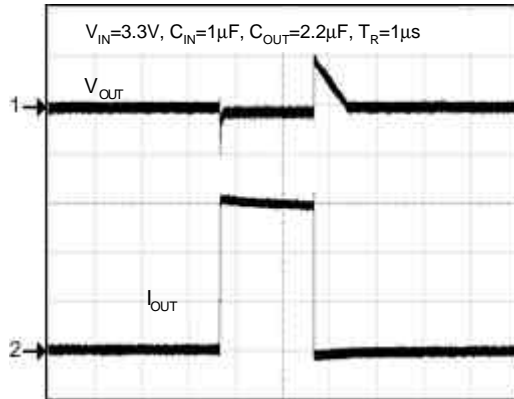

CH1 : V_{OUT} , 50mV/div, AC
 CH2 : I_{OUT} , 100mA/div, DC
 Time : 100μs/div

Line Transient

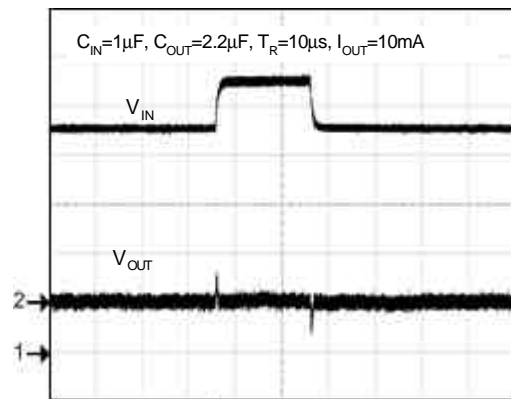

CH1 : V_{IN} , 1V/div, DC
 CH2 : V_{OUT} , 20mV/div, AC
 Time : 100μs/div

Enable

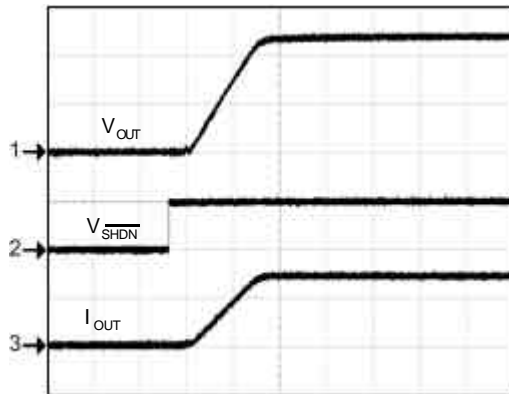

CH1 : V_{OUT} , 500mV/div
 CH2 : V_{SHDN} , 5V/div
 CH3 : I_{OUT} , 200mA/div
 Time : 50μs/div

Shutdown

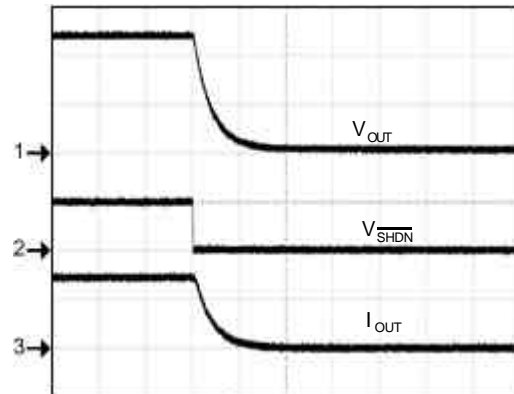

CH1 : V_{OUT} , 500mV/Div
 CH2 : V_{SHDN} , 5V/Div
 CH3 : I_{OUT} , 200mA/Div DC
 Time : 10μs/Div

Operating Waveforms (Cont.)

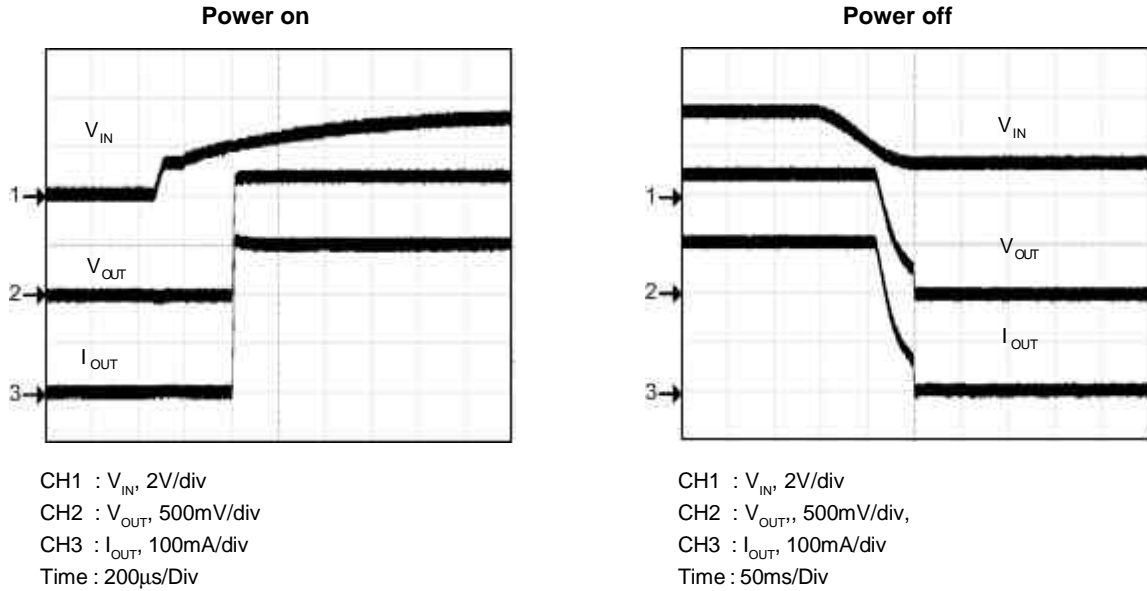

Pin Description

PIN		FUNCTION
NO.	NAME	
1	VIN	Voltage supply input pin
2	GND	Ground pin
3	$\overline{\text{SHDN}}$	Shutdown control pin, logic high: enable; logic low: shutdown
4	SET	Connect this pin to the ground for fixed output voltage operation. Connect this pin to an external resistor divider for adjustable output voltage mode operation.
5	VOUT	Regulator output pin

Block Diagram

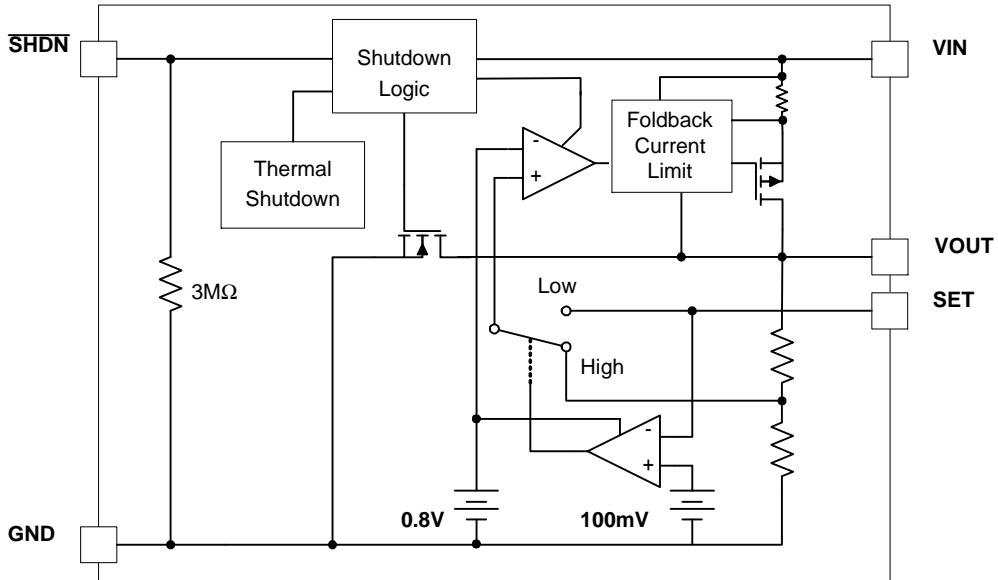

Typical Application Circuits

1. Fixed Output Voltage Mode

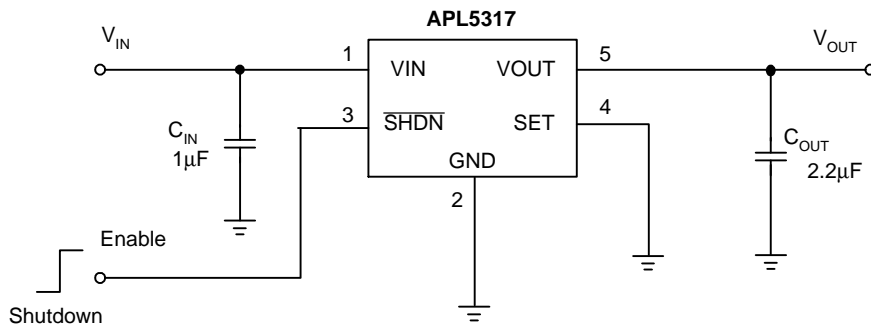

2.2μF/GRM155R60J225M Murata

Typical Application Circuits (Cont.)

2. Adjustable Output Voltage Mode

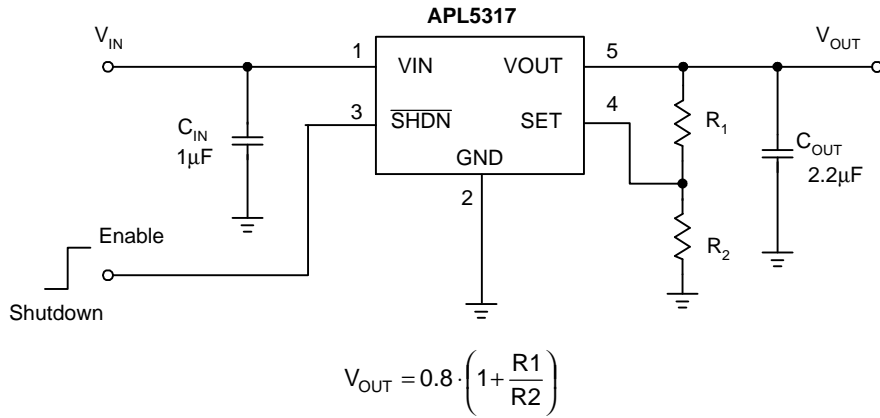

Function Description

Internal Soft-Start

An internal soft-start function controls rising rate of the output voltage to limit the surge current at start-up. The typical soft-start interval is about 80μs.

Output Voltage Regulation

The APL5317 can work in either fixed or adjustable mode by connecting the SET to GND or a resistor-divider which receives the feedback voltage of the regulator. The output voltage set by the resistor-divider is determined by:

$$V_{OUT} = 0.8 \cdot \left(1 + \frac{R1}{R2} \right)$$

Where R1 is connected from VOUT to SET with Kelvin sensing and R2 is connected from SET to GND. The recommended value of R2 is in the range of 100 to 100kΩ. An error amplifier works with a temperature compensated 0.8V reference and an output PMOS regulates the output to the presetting voltage. The error amplifier is designed with high bandwidth and DC gain provides very fast transient response and less load regulation. It compares the reference with the feedback voltage and amplifies the difference to drive the output PMOS which provides load current from VIN to VOUT.

Thermal Shutdown

A thermal shutdown circuit limits the junction temperature of APL5317. When the junction temperature exceeds +160°C, a thermal sensor turns off the output PMOS, allowing the device to cool down. The regulator regulates the output again through initiation of a new soft-start cycle after the junction temperature is cooled by 40°C. The thermal shutdown is designed with a 40°C hysteresis to lower the average junction temperature during continuous thermal overload conditions, extending lifetime of the device. For normal operation, device power dissipation should be externally limited, so that junction temperature will not exceed 125°C.

Under-Voltage Lock Out (UVLO)

The APL5317 monitors the input voltage to prevent wrong logic control. The UVLO function initiates a soft-start process after input voltage exceeds its rising UVLO threshold during power on. The UVLO function also shuts off the output when the input voltage falls below its falling threshold. Typical UVLO hysteresis voltage is 0.8V.

Shutdown Control

The APL5317 has an active-low shutdown function. Force $\overline{\text{SHDN}}$ high (>1.6V) enables the V_{OUT} ; force $\overline{\text{SHDN}}$ low (<0.4V) disables the V_{OUT} . $\overline{\text{SHDN}}$ is internally pulled low by a resistor (3MΩ typical). If $\overline{\text{SHDN}}$ is not used, it will connect to VIN for normal operation.

Application Information

Input Capacitor

The APL5317 requires proper input capacitors to supply surge current during stepping load transients to prevent the input rail from dropping. Because the parasitic inductor from the voltage sources or other bulk capacitors to the VIN limit the slew rate of the surge current, place the Input capacitors near VIN as close as possible. Input capacitors should be larger than 1μF and a minimum ceramic capacitor of 1μF is necessary.

Output Capacitor

The APL5317 needs a proper output capacitor to maintain circuit stability and improve transient response over temperature and current. In order to insure the circuit stability, the proper output capacitor value should be larger than 2.2μF. With X5R and X7R dielectrics, 2.2μF is sufficient at all operating temperatures. Large output capacitor value can reduce noise and improve load-transient response and PSRR, however, it also affects power on issue. Equation (1) shows the relationship between the maximum C_{OUT} value and V_{OUT}.

$$C_{OUT(max)} = 31 - \frac{6}{V_{OUT}} \dots\dots\dots(1)$$

Where the unit of C_{OUT} is μF and V_{OUT} is V, Figure 1 shows the curve of maximum output capacitor over the output voltage. The output voltage range is from 0.8 to 5.5V and the output capacitor value should be under the line. Output capacitors must be placed at the load and the ground pin as close as possible and the impedance of the layout must be minimized.

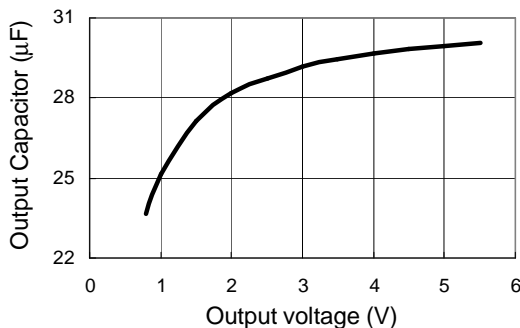

Figure 1

Operation Region and Power Dissipation

The APL5317 maximum power dissipation depends on the thermal resistance and temperature difference between the die junction and ambient air. The power dissipation P_D across the device is:

$$P_D = (T_J - T_A) / \theta_{JA}$$

where (T_J-T_A) is the temperature difference between the junction and ambient air. θ_{JA} is the thermal resistance between junction and ambient air. Assuming the T_A=25°C and maximum T_J=160°C (typical thermal limit threshold), the maximum power dissipation is calculated as:

$$P_{D(max)} = (160-25)/240 = 0.56(W)$$

For normal operation, do not exceed the maximum junction temperature rating of T_J = 125 °C. The calculated power dissipation should less than:

$$P_D = (125-25)/240 = 0.41(W)$$

The GND provides an electrical connection to ground and channels heat away. Connect the GND to the ground by using a large pad or a ground plane.

Layout Consideration

Figure 2 illustrates the layout. Below is a checklist for your layout:

1. Please place the input capacitors close to the VIN.
2. Ceramic capacitors for load must be placed near the load as close as possible.
3. To place APL5317 and output capacitors near the load is good for performance.
4. Large current paths, the bold lines in figure 2, must have wide tracks.
5. Divider resistor R1 and R2 must be placed near the SET as close as possible.

Application Information (Cont.)

PCB Layout Consideration (Cont.)

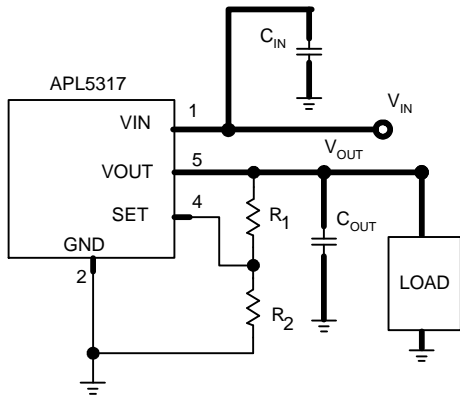
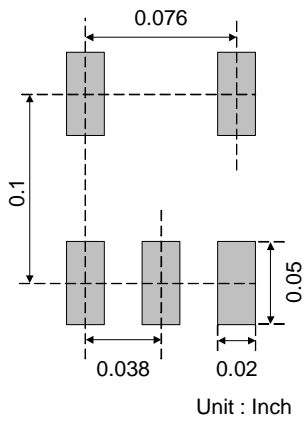

Figure 2

Recommended Minimum Footprint

SOT-23-5



Package Information

SOT-23-5

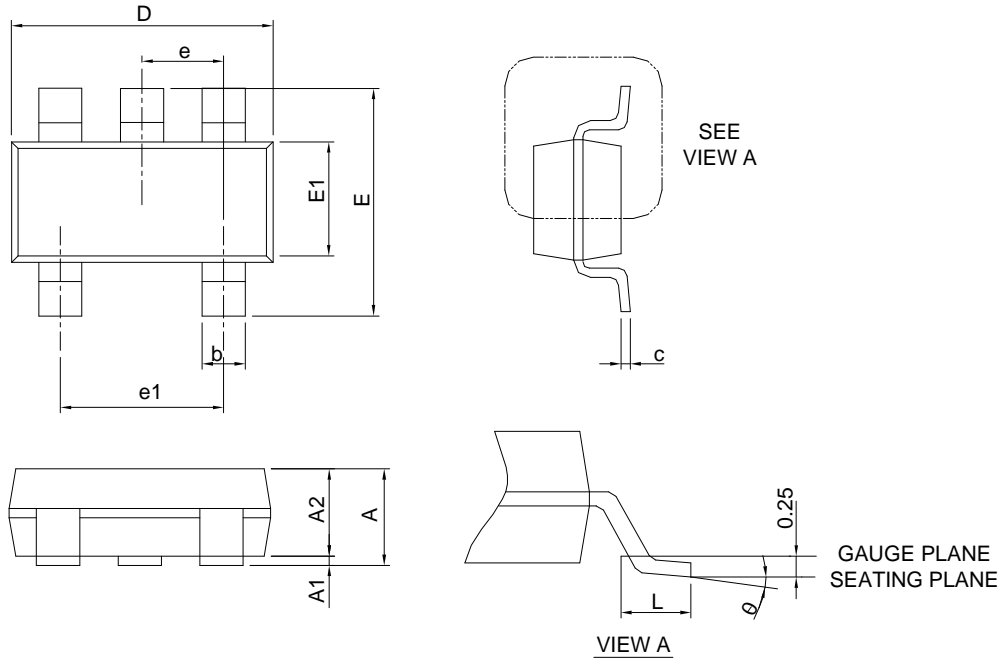

DIMENSIONS	SOT-23-5			
	MILLIMETERS		INCHES	
	MIN.	MAX.	MIN.	MAX.
A		1.45		0.057
A1	0.00	0.15	0.000	0.006
A2	0.90	1.30	0.035	0.051
b	0.30	0.50	0.012	0.020
c	0.08	0.22	0.003	0.009
D	2.70	3.10	0.016	0.122
E	2.60	3.00	0.102	0.118
E1	1.40	1.80	0.055	0.071
e	0.95 BSC		0.037 BSC	
e1	1.90 BSC		0.075 BSC	
L	0.30	0.60	0.012	0.024
θ	0°	8°	0°	8°

Note : 1. Follow JEDEC TO-178 AA.
 2. Dimension D and E1 do not include mold flash, protrusions or gate burrs. Mold flash, protrusion or gate burrs shall not exceed 10 mil per side.

Carrier Tape & Reel Dimensions

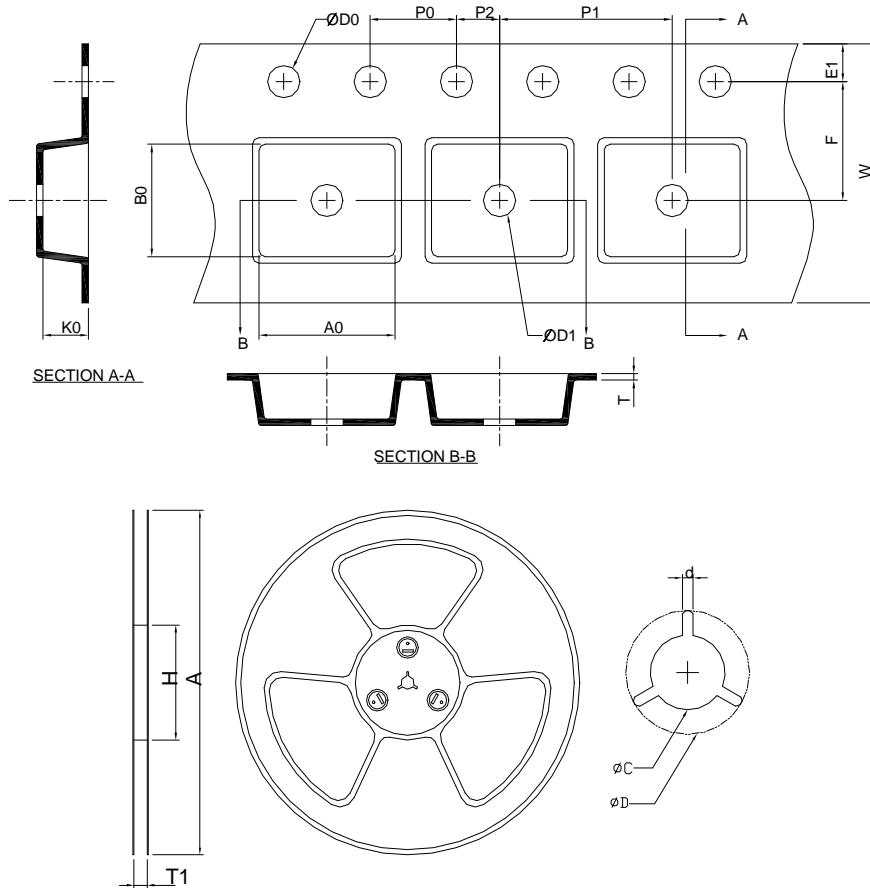

Application	A	H	T1	C	d	D	W	E1	F
SOT-23-5	178.0 ±0.00	50 MIN.	8.4+2.00 -0.00	13.0+0.50 -0.20	1.5 MIN.	20.2 MIN.	8.0 ±0.30	1.75 ±0.10	3.5 ±0.05
	P0	P1	P2	D0	D1	T	A0	B0	K0
	4.0 ±0.10	4.0 ±0.10	2.0 ±0.05	1.5+0.10 -0.00	1.0 MIN.	0.6+0.00 -0.40	3.20 ±0.20	3.10 ±0.20	1.50 ±0.20

(mm)

Devices Per Unit

Package Type	Unit	Quantity
SOT-23-5	Tape & Reel	3000

Taping Direction Information

SOT-23-5

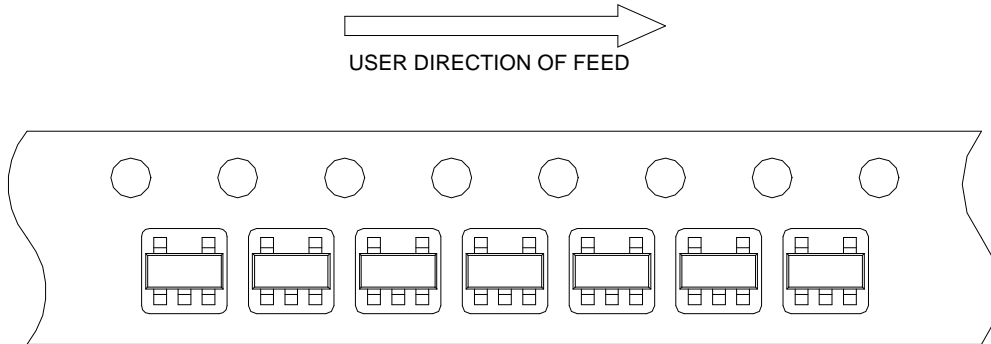

Classification Profile

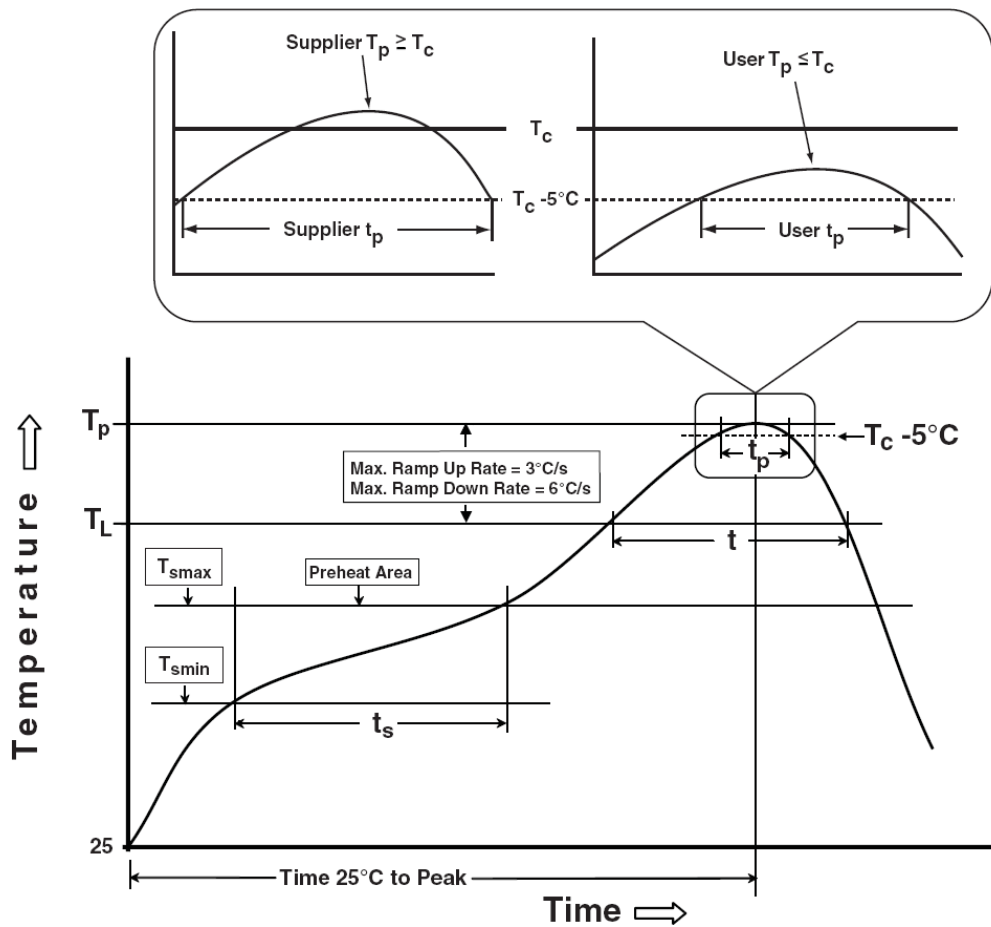

Classification Reflow Profiles

Profile Feature	Sn-Pb Eutectic Assembly	Pb-Free Assembly
Preheat & Soak		
Temperature min (T_{smin})	100 °C	150 °C
Temperature max (T_{smax})	150 °C	200 °C
Time (T_{smin} to T_{smax}) (t_s)	60-120 seconds	60-120 seconds
Average ramp-up rate (T_{smax} to T_p)	3 °C/second max.	3°C/second max.
Liquidous temperature (T_L)	183 °C	217 °C
Time at liquidous (t_L)	60-150 seconds	60-150 seconds
Peak package body Temperature (T_p)*	See Classification Temp in table 1	See Classification Temp in table 2
Time (t_p)** within 5°C of the specified classification temperature (T_c)	20** seconds	30** seconds
Average ramp-down rate (T_p to T_{smax})	6 °C/second max.	6 °C/second max.
Time 25°C to peak temperature	6 minutes max.	8 minutes max.
* Tolerance for peak profile Temperature (T_p) is defined as a supplier minimum and a user maximum.		
** Tolerance for time at peak profile temperature (t_p) is defined as a supplier minimum and a user maximum.		

Table 1. SnPb Eutectic Process – Classification Temperatures (T_c)

Package Thickness	Volume mm ³ <350	Volume mm ³ ≥350
<2.5 mm	235 °C	220 °C
≥2.5 mm	220 °C	220 °C

Table 2. Pb-free Process – Classification Temperatures (T_c)

Package Thickness	Volume mm ³ <350	Volume mm ³ 350-2000	Volume mm ³ >2000
<1.6 mm	260 °C	260 °C	260 °C
1.6 mm – 2.5 mm	260 °C	250 °C	245 °C
≥2.5 mm	250 °C	245 °C	245 °C

Reliability Test Program

Test item	Method	Description
SOLDERABILITY	JESD-22, B102	5 Sec, 245°C
HOLT	JESD-22, A108	1000 Hrs, Bias @ 125°C
PCT	JESD-22, A102	168 Hrs, 100%RH, 2atm, 121°C
TCT	JESD-22, A104	500 Cycles, -65°C~150°C
ESD	MIL-STD-883-3015.7	VHBM 2KV, VMM 200V
Latch-Up	JESD 78	10ms, 1 _{tr} 100mA

Customer Service

Anpec Electronics Corp.

Head Office :

No.6, Dusing 1st Road, SBIP,

Hsin-Chu, Taiwan, R.O.C.

Tel : 886-3-5642000

Fax : 886-3-5642050

Taipei Branch :

2F, No. 11, Lane 218, Sec 2 Jhongsing Rd.,

Sindian City, Taipei County 23146, Taiwan

Tel : 886-2-2910-3838

Fax : 886-2-2917-3838