

**Ø 9,43" x 3,346"    Ø 239,5 x 85 mm**

**62GP**

**ETRI®**

AC High Performance Fans

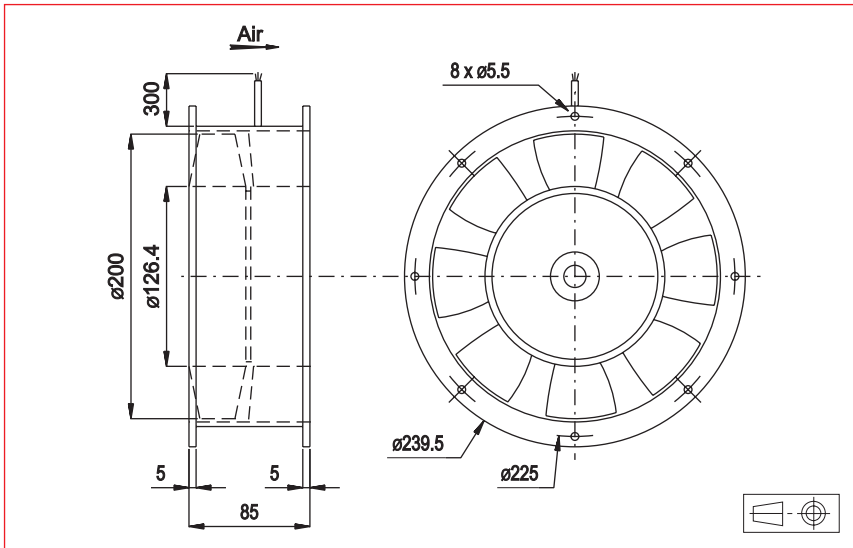

**Approvals**

CE, NATO codification

**Life expectancy**

L-10 LIFE AT 40°C:  
25 000 hours

**AC Motor**

Housing material: aluminium  
Impeller material: aluminium  
Weight: 4,2 kg  
Bearing system: ball bearings

**Available with:**

- Safety switch
- Terminal block
- Plastic impeller (61G series)

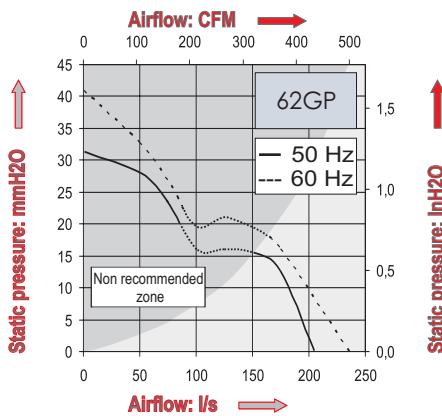

Part Number	Nominal voltage	Airflow	Noise level	Nominal speed	Frequency	Phases	Capacitor (not included)	Input power	Nominal Current	Starting Current	Connection type		Operating temperature	
	V	l/s	dB(A)	RPM	Hz		µF	W	mA	mA	Leads	Terminals	Min.°C	Max.°C
62GP016DC13	220	205	63	2900	50	3		45	270	1300	X		-10	70
	380	205	63	2900	50	3		45	155	750	X		-10	70
	220	240	66	3400	60	3		58	230	1200	X		-10	70
	380	240	66	3400	60	3		58	135	700	X		-10	70
	220	205	63	2900	50	1	3,2	46	260	1100	X		-10	70
	380	205	63	2900	50	1	1	46	150	650	X		-10	70
	220	240	66	3400	60	1	3,2	61	280	1000	X		-10	70
	380	240	66	3400	60	1	1	61	160	600	X		-10	70

**Additional versions:**

Salt spray protected - Shock and vibration protected - Marine specifications  
Wide temperature range - Other voltages (consult factory)

**Accessories:**

Refer to Accessories leaflet