

STRUCTURE	Silicon Monolithic Integrated Circuit
PRODUCT SERIES	Single-Phase Full-Wave Motor Driver for Fan Motor
TYPE	B A 6 9 0 6 F
FEATURES	Soft switched drive

○ABSOLUTE MAXIMUM RATINGS

Parameter	Symbol	Limit	Unit
Supply voltage	Vcc	15	V
Power dissipation	Pd	780 *	mW
Operating temperature	Topr	-40~+100	°C
Storage temperature	Tstg	-55~+150	°C
Output current	Iomax	0.7 * *	A
Output voltage	VOUT	15	V
AL signal output current	IAL	15	mA
AL signal output voltage	VAL	15	V
Junction temperature	Tjmax	150	°C

* To use at temperature above Ta=25°C reduce 6.24mW/°C.
(On 70.0mm×70.0mm×1.6mm glass epoxy board)

* * This value is not to be over Pd.

○OPERATING CONDITIONS

Parameter	Symbol	Limit	Unit
Operating supply voltage range	Vcc	3.0~14.0	V
Hall input voltage range	VH	0~Vcc-2.0	V

* This product is not designed for production against radioactive rays.

* This document may be strategic data subject to COCOM regulations.

○ELECTRICAL CHARACTERISTICS (Unless otherwise specified Ta=25°C, Vcc=5V)

Parameter	Symbol	Limit			Unit	Conditions
		Min.	Typ.	Max.		
Circuit current	Icc	1.5	3.4	8.7	mA	At output OFF
Charge current of capacitor for lock detection	ILDC	1.50	2.75	4.50	μA	VLD=1.1V
Discharge current of capacitor for lock detection	ILDD	0.24	0.48	0.90	μA	VLD=1.1V
Charge-discharge current ratio of capacitor for lock detection	rCD	4.2	5.7	9.5	-	rCD=ILDC/ILDD
Clamp voltage of capacitor for lock detection	VLDCL	1.14	1.80	2.47	V	
Comparison voltage of capacitor for lock detection	VLDCP	0.47	0.76	1.06	V	
Output voltage L	VOL	-	0.2	0.3	V	Io=200mA
Output voltage H	VOH	3.9	4.1	-	V	Io=-200mA
FG terminal voltage L	VALL	-	0.3	0.5	V	IALL=5mA
FG terminal leak current	IALL	-	0	50	μA	VAL=15V
Hall input offset voltage	Hofs	-10	-	10	mV	
Hall input-output gain	GHO	320	500	680	-	

○PACKAGE OUTLINES

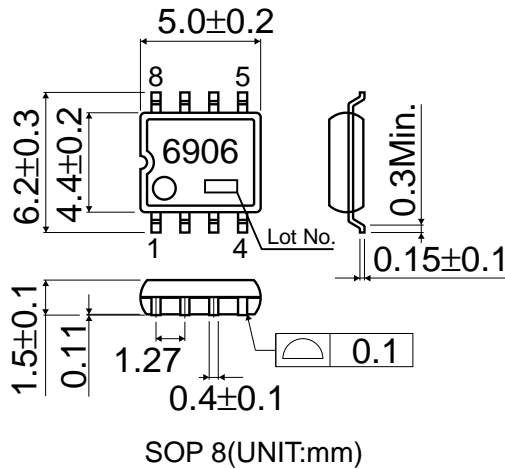

○BLOCK DIAGRAM

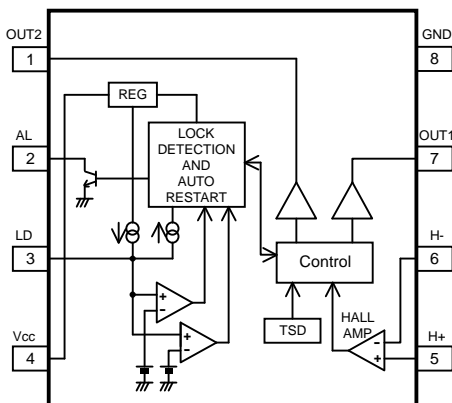

○Terminal name

Pin No.	Terminal name
1	OUT2
2	AL
3	LD
4	Vcc
5	H+
6	H-
7	OUT1
8	GND

CAUTIONS

- 1) Absolute maximum ratings
There is possibility of destruction in using beyond the absolute maximum rating. In case of destruction, a failure mode can not be defined (short mode or open mode). Therefore when special mode is envisaged where absolute maximum rating may be exceeded, please take a physical safety measure such as fuse.
- 2) Reverse connection of power supply connector
Reverse connection of power supply connector may break IC. Take a measure against reverse connection destruction such as inserting a diode between power supply and Vcc terminal.
- 3) Power supply line
Back electromotive force causes regenerated current to power supply line, therefore take a measure such as placing a capacitor between power supply and GND for routing regenerated current, and fully ensure that the capacitor characteristics have no problem before determine a capacitor value
- 4) GND potential
Ensure that the potential of GND terminal is the minimum potential in any operating condition. Also ensure that all terminals except GND terminal do not fall below GND voltage including transient characteristics. However, it is possible that the motor output terminal may deflect below GND because of influence by back electromotive force of motor. Malfunction may possibly occur depending on use condition, environment, and property of individual motor. Please make fully confirmation that no problem is found on operation of IC.
- 5) Thermal design
Consider the power dissipation under actual use condition and apply thermal design with sufficient margin.
- 6) Mounting failures
In attaching IC to printed board, pay enough attention to the direction and dislocation of IC. Mounting failures may break IC. In addition, destruction is also possible when circuit is shorted by foreign substance brought between outputs or between output and power supply - GND.
- 7) Operation in strong electromagnetic field
Use in strong electromagnetic field may cause malfunction, please be careful.
- 8) ASO
Please consider that the output Tr does not exceed the absolute maximum rating and ASO.
- 9) Thermal shut down circuit
This IC has thermal shut down (TSD) circuit. Operation temperature is 175°C(typ.) and has a hysteresis width of 25°C(typ.). When IC chip temperature rises and TSD circuit works, the output terminal becomes an open state. TSD circuit is simply for the purpose of intercepting IC from overheating, and not for protecting and assuring IC. Therefore do not continue to use IC thereafter with this circuit operating and do not use IC assuming the operation of this circuit.
- 10) Inspection with a set board
When connecting a capacitor to a pin with low impedance in inspection on a set board, stress may possibly be applied to IC, therefore be sure to apply discharging in each process. In attaching to and detaching from jigs in inspection process, be sure to turn off power before connecting, and turn off power before removing IC. In addition, apply grounding to assembling process as a measure of anti-static electricity, and use full caution in transporting and storing.
- 11) GND wiring pattern
When there are small signal GND and large current GND, separate the large current GND pattern from small signal GND pattern. It is recommended to apply one-point grounding at the reference point of the set in order that resistance of wiring pattern and large current do not cause change of voltage of small signal GND. Please be cautious not to fluctuate the wiring pattern of GND of external mounted parts.
- 12) Capacitor between output and GND
When a large capacitor is connected between output and GND, if Vcc is shorted with 0V or GND for some cause, it is possible that the current charged in the capacitor may flow into the output resulting in destruction. Keep the capacitor between output and GND below 100uF.
- 13) IC terminal input
When Vcc voltage is not applied to IC, do not apply voltage to each input terminal. When voltage above Vcc or below GND is applied to the input terminal, parasitic element is actuated due to the structure of IC. Operation of parasitic element causes mutual interference between circuits, resulting in malfunction as well as destruction in the last. Do not use in a manner where parasitic element is actuated.

Notes

No copying or reproduction of this document, in part or in whole, is permitted without the consent of ROHM CO.,LTD.

The content specified herein is subject to change for improvement without notice.

The content specified herein is for the purpose of introducing ROHM's products (hereinafter "Products"). If you wish to use any such Product, please be sure to refer to the specifications, which can be obtained from ROHM upon request.

Examples of application circuits, circuit constants and any other information contained herein illustrate the standard usage and operations of the Products. The peripheral conditions must be taken into account when designing circuits for mass production.

Great care was taken in ensuring the accuracy of the information specified in this document. However, should you incur any damage arising from any inaccuracy or misprint of such information, ROHM shall bear no responsibility for such damage.

The technical information specified herein is intended only to show the typical functions of and examples of application circuits for the Products. ROHM does not grant you, explicitly or implicitly, any license to use or exercise intellectual property or other rights held by ROHM and other parties. ROHM shall bear no responsibility whatsoever for any dispute arising from the use of such technical information.

The Products specified in this document are intended to be used with general-use electronic equipment or devices (such as audio visual equipment, office-automation equipment, communication devices, electronic appliances and amusement devices).

The Products are not designed to be radiation tolerant.

While ROHM always makes efforts to enhance the quality and reliability of its Products, a Product may fail or malfunction for a variety of reasons.

Please be sure to implement in your equipment using the Products safety measures to guard against the possibility of physical injury, fire or any other damage caused in the event of the failure of any Product, such as derating, redundancy, fire control and fail-safe designs. ROHM shall bear no responsibility whatsoever for your use of any Product outside of the prescribed scope or not in accordance with the instruction manual.

The Products are not designed or manufactured to be used with any equipment, device or system which requires an extremely high level of reliability the failure or malfunction of which may result in a direct threat to human life or create a risk of human injury (such as a medical instrument, transportation equipment, aerospace machinery, nuclear-reactor controller, fuel-controller or other safety device). ROHM shall bear no responsibility in any way for use of any of the Products for the above special purposes. If a Product is intended to be used for any such special purpose, please contact a ROHM sales representative before purchasing.

If you intend to export or ship overseas any Product or technology specified herein that may be controlled under the Foreign Exchange and the Foreign Trade Law, you will be required to obtain a license or permit under the Law.

Thank you for your accessing to ROHM product informations.

More detail product informations and catalogs are available, please contact your nearest sales office.

ROHM Customer Support System

THE AMERICAS / EUROPE / ASIA / JAPAN

www.rohm.com

Contact us : webmaster@rohm.co.jp