

# TS128M~8GSDOM7H

## 7P Horizontal Type SATA Flash Modules

### Description

Serial-ATA is designed as a successor to the legacy SATA standard. The new standard is dedicated to achieve higher transfer rate with thinner cables and more reliable operation than Parallel ATA interface. SATA Flash Modules is perfect replacement storage device for PCs, Laptops, gaming systems, and handheld devices.

### Placement

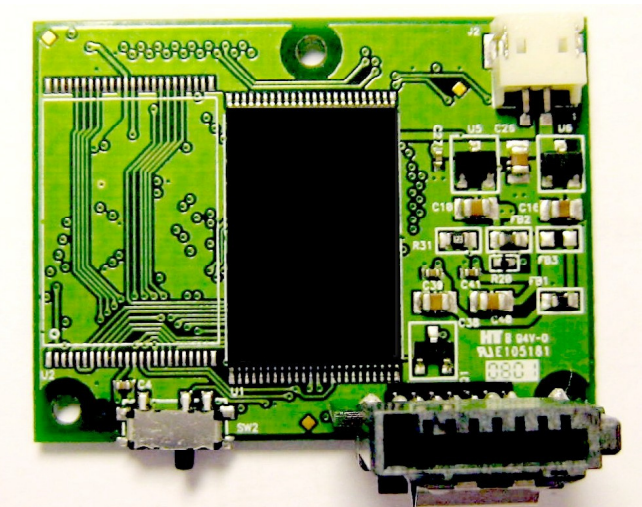
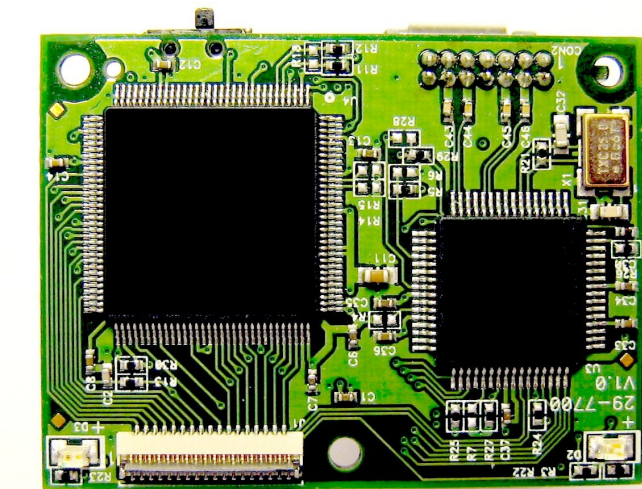

### Features

- RoHS compliant
- Fully compatible with devices and OS that support the SATA 1.0a 1.5Gbps standard
- 7 pin female SATA connector with latch
- Connect to motherboard directly without cable
- Non-volatile Flash Memory for outstanding data retention
- The on-chip hardware 13/24 bit BCH-ECC engines can correct up to 24 bit errors per 1,024 byte data.
- Support global wear-leveling algorithm which ensures maximum lifespan.
- Supports
  - Ultra DMA Mode 0 to 5
  - Multiword DMA mode 0 to 2
  - PIO Mode 0 to 4
- Supports ATA Security Commands
- Support S.M.A.R.T function (self-definition)
- Mechanical write-protect switch
- Low Power Consumption
- Power Supply: 3.3V  $\pm$  5%(UDMA mode 5) / 5.0V  $\pm$  10%(UDMA mode 4 or lower)
- Shock resistance

### Dimensions

Side	Millimeters	Inches
A	40.0 $\pm$ 0.3	1.57 $\pm$ 0.012
B	30.0 $\pm$ 0.2	1.18 $\pm$ 0.008
C*	24.3 $\pm$ 0.5	0.96 $\pm$ 0.020

\* Please refer to Mechanical Drawing

# TS128M~8GSDOM7H

7P Horizontal Type  
SATA Flash Modules

## Specifications

Physical Specification		
Form Factor	SATA Flash Module Horizontal Type	
Storage Capacities	128M~8GB	
Dimensions (mm)	Length	40.0 ± 0.3
	Width	30.0 ± 0.2 (Not including Write-Protect Switch and SATA connector)
	Height	24.3 ± 0.5 (refer to mechanical drawing)
Input Voltage	5V ± 10% / 3.3V ± 5%	
Weight	8 g	
Connector	Signal: SATA 7 pins female connector with latch Power: 2P 1.5mm pitch wafer connector	

Environmental Specifications	
Operating Temperature	0 °C to 70 °C
Storage Temperature	- 40 °C to 85 °C

Power Consumption		
4GB SATA Flash Modules Power Consumption (DC 5V @25°C)		<b>Crystal Disk Mark 1.0.6 / 50MB</b>
	Read	212.2 mA(peak)
	Write	207.3 mA(peak)
	Standby	111.8 mA

# TS128M~8GSDOM7H

## 7P Horizontal Type SATA Flash Modules

Reliability	
Data Reliability	13bit/1K Byte BCH ECC(2k+64 / 4k+128 byte per page flash) 24bit/1K Byte BCH ECC(4k+208 byte per page flash)
Data Retention	10 years
Connector Durability	500 mating cycles

Performance*				
Model P/N	Read (KB/s)	Write (KB/s)	Random Read (KB/s)	Random Write (KB/s)
2GB SATA Flash Module	53696	25491	51174	10518

\* Note : The performance is based on Samsung K9F8G08U0M, single channel. Environment: at 25 °C, tested with GA-8IG1000MK, 256 MB RAM, SATA interface support UDMA5, Windows® XP Version 2002 SP2, benchmark utility : HDBENCH (version 3.4006), copied file 100MB

Actual Capacity				
Model P/N	Capacity	C/H/S	Capacity	User capacity (Bytes)
TS512MSDOM7H	512M	971 / 16 / 63	477MB	500,432,896
TS1GSDOM7H	1GB	1966 / 16 / 63	967MB	1,014,333,440
TS2GSDOM7H	2GB	3900 / 16 / 63	1.87GB	2,008,801,280
TS4GSDOM7H	4GB	7785 / 16 / 63	3.73GB	4,009,922,560
TS8GSDOM7H	8GB	15538 / 16 / 63	7.46GB	8,016,560,128

\* Note: FAT format for <4GB, FAT32 format for 4~8GB

Certification	
EMC	CE, FCC and BSMI (T.B.D)

# TS128M~8GSDOM7H

7P Horizontal Type  
SATA Flash Modules

## Mechanical Drawing

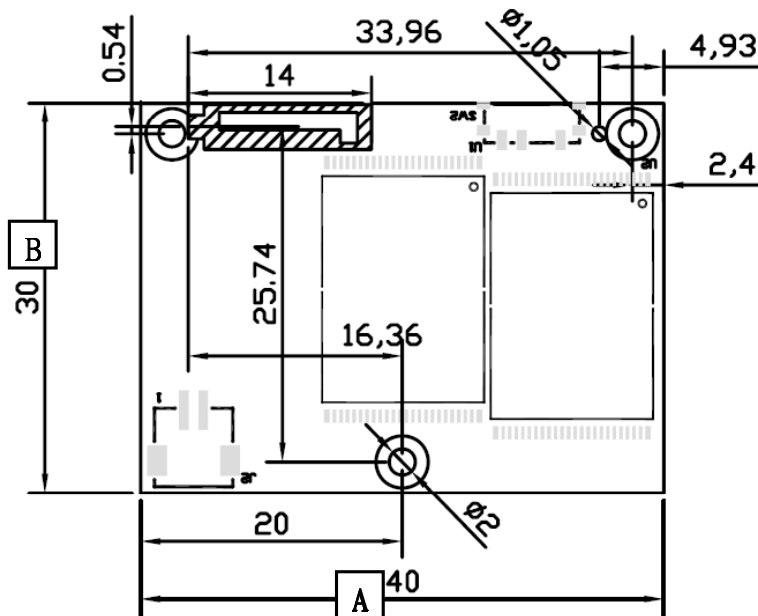

Bottom View (Normal Type)

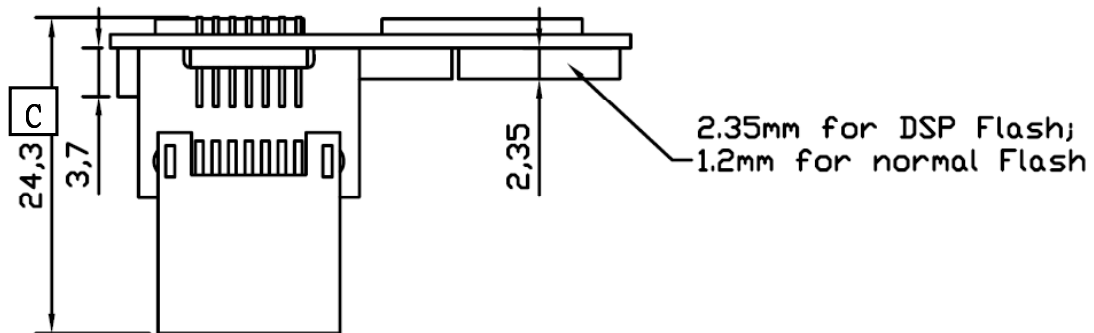

Side View (Normal Type)



# TS128M~8GSDOM7H

## 7P Horizontal Type SATA Flash Modules

### Functionality

#### Pin Assignments

Pin No.	Pin Name
01	GND
02	A+
03	A-
04	GND
05	B-
06	B+
07	GND

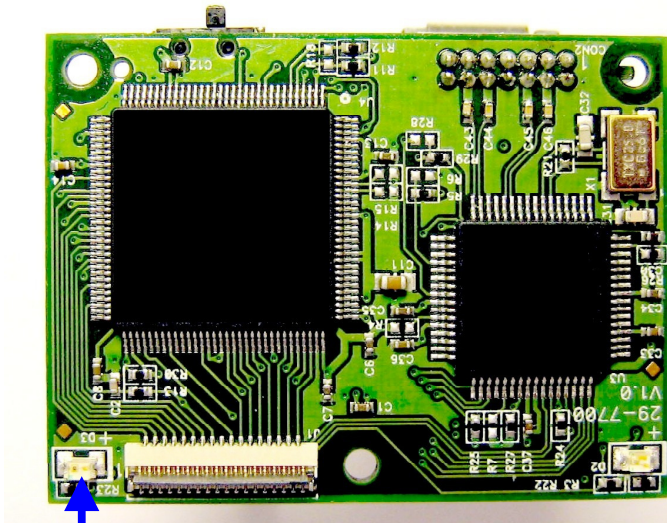
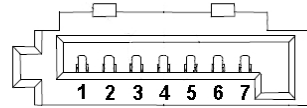

Disk Active  
Indicator

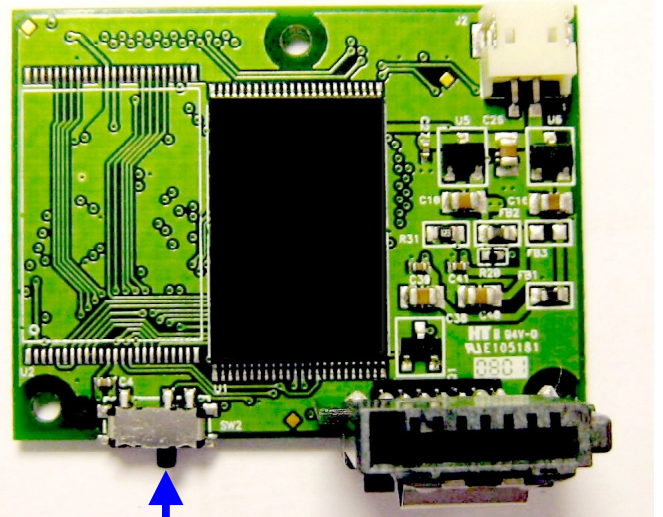

Write-Protect  
Disabled

### Block Diagram

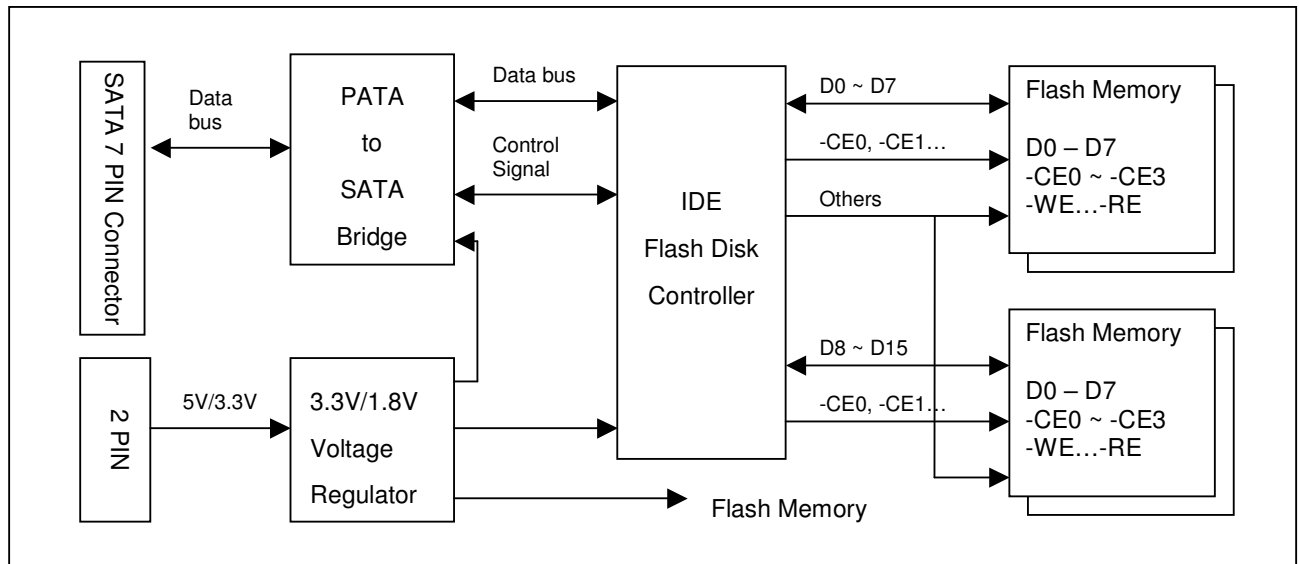

### DC Characteristics

Parameter	Symbol	Min.	Max.	Unit	Remark
Supply Voltage	$V_{CC}$	2.97	5.5	V	
High level output voltage	$V_{OH}$	$V_{CC} - 0.8$		V	
Low level output voltage	$V_{OL}$		0.8	V	
High level input voltage	$V_{IH}$	2.4		V	Non-schmitt trigger
		2.05		V	Schmitt trigger <sup>1</sup>
Low level input voltage	$V_{IL}$		0.6	V	Non-schmitt trigger
			1.25	V	Schmitt trigger <sup>1</sup>
Pull up resistance <sup>2</sup>	$R_{PU}$	52.7	141	KOhm	
Pull down resistance	$R_{PD}$	47.5	172	kOhm	

1. Include CE1, CE2, HREG, HOE, HIOE, HWE, HIOW pins.

2. Include CE1, CE2, HREG, HOE, HIOE, HWE, HIOW, CSEL(P35), PDIAG, DASP pins.

### Command Set

	Command	Code	FR	SC	SN	CY	DH	LBA	Status	Note
1	Check Power Mode	E5 or 98h	-	-	-	-	Y	-	Support	
2	Execute Drive Diagnostic	90h	-	-	-	-	Y	-	Support	
3	Erase Sector	C0h	-	Y	Y	Y	Y	Y	Support	
4	Flush Cache	E7h	-	-	-	-	Y	-	Support	
5	Format Track	50h	-	Y	-	Y	Y	Y	Support	
6	Identify Device	ECh	-	-	-	-	Y	-	Support	
7	Idle	E3h or 97h	-	Y	-	-	Y	-	Support	
8	Idle Immediate	E1h or 95h	-	-	-	-	Y	-	Support	
9	Initialize Drive Parameters	91h	-	Y	-	-	Y	-	Support	
10	NOP	00h	-	-	-	-	Y	-	Support	
11	Read Buffer	E4h	-	-	-	-	Y	-	Support	
12	Read DMA	C8h	-	Y	Y	Y	Y	Y	Support	
13	Read Multiple	C4h	-	Y	Y	Y	Y	Y	Support	
14	Read Sector(s)	20h or 21h	-	Y	Y	Y	Y	Y	Support	
15	Read Verify Sector(s)	40h or 41h	-	Y	Y	Y	Y	Y	Support	
16	Recalibrate	1Xh	-	-	-	-	Y	-	Support	
17	Request Sense	03h	-	-	-	-	Y	-	Support	
18	Security Disable Password	F6h	-	-	-	-	Y	-	Support	
19	Security Erase Prepare	F3h	-	-	-	-	Y	-	Support	
20	Security Erase Unit	F4h	-	-	-	-	Y	-	Support	
21	Security Freeze Lock	F5h	-	-	-	-	Y	-	Support	
22	Security Set Password	F1h	-	-	-	-	Y	-	Support	
23	Security Unlock	F2h	-	-	-	-	Y	-	Support	
24	Seek	7Xh	-	-	Y	Y	Y	Y	Support	
25	Set Feature	EFh	Y	-	-	-	Y	-	Support	
26	Set Multiple Mode	C6h	-	Y	-	-	Y	-	Support	
27	Set Sleep Mode	E6h or 99h	-	-	-	-	Y	-	Support	
28	Standby	E2 or 96h	-	-	-	-	Y	-	Support	
29	Standby Immediate	E0 or 94h	-	-	-	-	Y	-	Support	



30	Translate Sector	87h	-	Y	Y	Y	Y	Y	Support	
31	Wear Level	F5h	-	-	-	-	Y	-	Support	
32	Write Buffer	E8h	-	-	-	-	Y	-	Support	
33	Write DMA	CAh	-	Y	Y	Y	Y	Y	Support	
34	Write Multiple	C5h	-	Y	Y	Y	Y	Y	Support	
35	Write Multiple w/o Erase	CDh	-	Y	Y	Y	Y	Y	Support	
36	Write Sector(s)	30h or 31h	-	Y	Y	Y	Y	Y	Support	
37	Write Sector(s) w/o Erase	38h	-	Y	Y	Y	Y	Y	Support	
38	Write Verify	3Ch	-	Y	Y	Y	Y	Y	Support	

### Definitions

FR = Features Register

SC =Sector Count register (00H to FFH, 00H means 256 sectors)

SN = Sector Number register

CY = Cylinder Low/High register

DH = Head No. (0 to 15) of Drive/Head register

LBA = Logic Block Address Mode Support

- = Not used for the command

Y = Used for the command

### SMART Command Set

#### ● SMART Command Set

SMART Feature Register Values			
D0h	Read Data	D5h	Read Log
D1h	Read Attribute Threshold	D6h	Write Log
D2h	Enable/Disable Autosave	D8h	Enable SMART Operations
D3h	Save Attribute Values	D9h	Disable SMART Operations
D4h	Execute OFF-LINE Immediate	DAh	Return Status

1. If reserved size is below the Threshold, the status can be read from Cylinder register by Return Status command (DAh).

#### ● SMART Data Structure

BYTE	F / V	Decription
0-1	X	Revision code
2-361	X	Vendor specific
362	V	Off line data collection status
363	X	Self-test execution status byte
364-365	V	Total time in seconds to complete off-line data collection activity
366	X	Vendor specific
367	F	Off-line data collection capability
368-369	F	SMART capability
370	F	Error logging capability 7-1 Reserved 0 1=Device error logging supported
371	X	Vendor specific
372	F	Short self-test routine recommended polling time (in minutes)
373	F	Extended self-test routine recommended polling time (in minutes)
374	F	Conveyance self-test routine recommended polling time (in minutes)
375-385	R	Reserved
386-395	F	Date Code
396-397	F	Number of initial invalid block (396 = MSB, 397 = LSB)
398-399	V	Number of run time bad block (398 = MSB, 399 = LSB)
400	V	Number of spare block

511	V	Data structure checksum
-----	---	-------------------------

F=the content of the byte is fixed and does not change.  
V=the content of the byte is variable and may change depending on the state of the device or the commands executed by the device.  
X=the content of the byte is vendor specific and may be fixed or variable.  
R=the content of the byte is reserved and shall be zero.

\* 4 Byte value : [MSB] [2] [1] [LSB]

### ID Table Information

Word Address	Default Value	Total Bytes	Data Field Type Information
	044Ah	2	General configuration – Bit Significant with ATA-7 definitions.
1	XXXXh	2	Default number of cylinders
2	0000h	2	Reserved
3	00XXh	2	Default number of heads
4	0000h	2	Obsolete
5	0240h	2	Obsolete
6	XXXXh	2	Default number of sectors per track
7-8	XXXXh	4	Number of sectors per card (Word 7 = MSW, Word 8 = LSW)
9	XXXXh	2	Obsolete
10-19	aaaa	20	Serial number in ASCII (Right Justified)
20	0002h	2	Obsolete
21	0002h	2	Obsolete
22	0000h	2	Number of ECC bytes passed on Read/Write Long Commands
23-26	aaaa	8	Firmware revision in ASCII. Big Endian Byte Order in Word
27-46	aaaa	40	Model number in ASCII (Left Justified) Big Endian Byte Order in Word
47	XXXXh	2	Maximum number of sectors on Read/Write Multiple command
48	0000h	2	Reserved
49	0F00h	2	Capabilities ( Default)
50	0000h	2	Reserved
51	0200h	2	PIO data transfer cycle timing mode (PIO mode 2)
52	0000h	2	Obsolete
53	0007h	2	Field Validity
54	XXXXh	2	Current numbers of cylinders
55	XXXXh	2	Current numbers of heads
56	XXXXh	2	Current sectors per track
57-58	XXXXh	4	Current capacity in sectors (LBAs)(Word 57 = LSW, Word 58 = MSW)
59	0100h	2	Multiple sector setting
60-61	XXXXh	4	Total number of sectors addressable in LBA Mode
62	0000h	2	Reserved
63	0007h	2	Multiword DMA transfer. (Support Multiword mode 0-2)
64	0003h	2	Advanced PIO modes supported (Support PIO mode 3 and PIO mode 4)
65	0078h	2	Minimum Multiword DMA transfer cycle time per word. (120ns)
66	0078h	2	Recommended Multiword DMA transfer cycle time. (120ns)
67	0078h	2	Minimum PIO transfer cycle time without flow control (120ns)

<b>Word Address</b>	<b>Default Value</b>	<b>Total Bytes</b>	<b>Data Field Type Information</b>
68	0078h	2	Minimum PIO transfer cycle time with IORDY flow control (120ns)
69-79	0000h	22	Reserved
80	0080h	2	Major revision number
81	0000h	2	Minor revision number
82	742Bh	2	Command sets supported 0
83	5008h	2	Command sets supported 1
84	4003h	2	Command sets supported 2
85	XXXXh	2	Command sets Enable 0
86	XXXXh	2	Command sets Enable 1
87	4003h	2	Command sets Enable 2
88	003Fh	2	Ultra DMA Mode Supported and Selected
89	0001h	2	Time required for Security erase unit completion (2 min)
90	0000h	2	Time required for Enhanced security erase unit completion
91	0000h	2	Current Advanced power management value
92	0000h	2	Reserved
93	XXXXh	2	Hardware configuration test result
94-127	0000h	68	Reserved
128	0001h	2	Security status (Default)
129-159	0000h	62	Vendor unique bytes
160	0000h	2	Power requirement description
161-255	0000h	190	Reserved

# TS128M~8GSDOM7H

7P Horizontal Type  
SATA Flash Modules

## Ordering Information

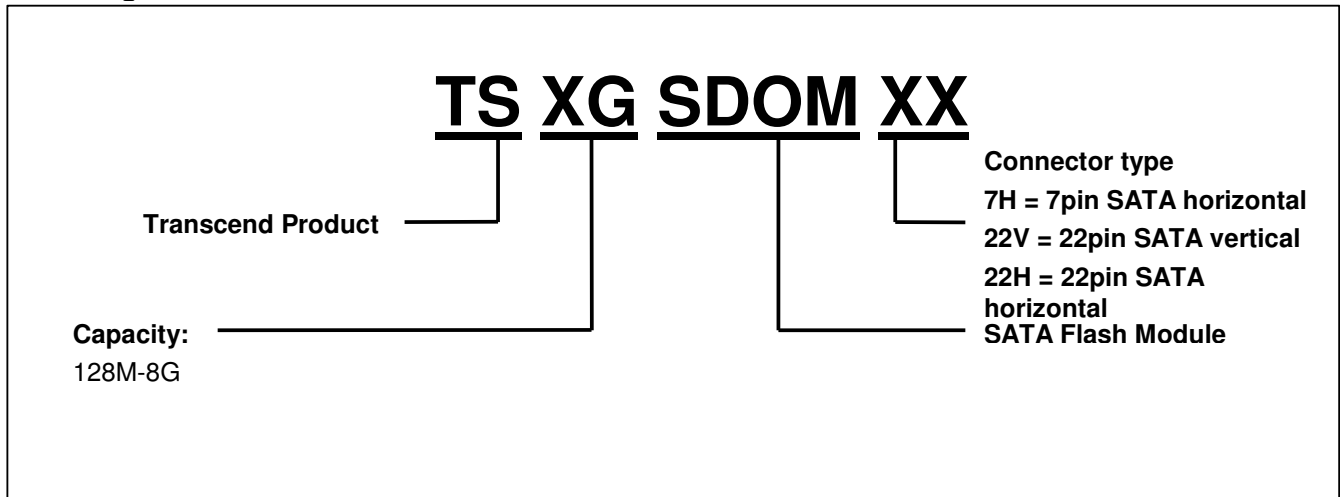

1. The above technical information is based on industry standard data and has been tested to be reliable. However, Transcend makes no warranty, either expressed or implied, as to its accuracy and assumes no liability in connection with the use of this product. Transcend reserves the right to make changes to the specifications at any time without prior notice.

2. For specific capacity, performance, and reliability requirement, please contact with sales.

	<b>USA</b> <b>Los Angeles:</b> E-mail: <a href="mailto:sales@transcendusa.com">sales@transcendusa.com</a> <b>Maryland:</b> E-mail: <a href="mailto:sales_md@transcendusa.com">sales_md@transcendusa.com</a> <a href="http://www.transcendusa.com">www.transcendusa.com</a>
	<b>CHINA</b> E-mail: <a href="mailto:sales@transcendchina.com">sales@transcendchina.com</a> <a href="http://www.transcendchina.com">www.transcendchina.com</a>
<b>TAIWAN</b> No.70, XingZhong Rd., NeiHu Dist., Taipei, Taiwan, R.O.C TEL +886-2-2792-8000 Fax +886-2-2793-2222 E-mail: <a href="mailto:sales@transcend.com.tw">sales@transcend.com.tw</a> <a href="http://www.transcend.com.tw">www.transcend.com.tw</a>	<b>GERMANY</b> E-mail: <a href="mailto:vertrieb@transcend.de">vertrieb@transcend.de</a> <a href="http://www.transcend.de">www.transcend.de</a>
	<b>HONG KONG</b> E-mail: <a href="mailto:sales@transcend.com.hk">sales@transcend.com.hk</a> <a href="http://www.transcendchina.com">www.transcendchina.com</a>
	<b>JAPAN</b> E-mail: <a href="mailto:sales@transcend.co.jp">sales@transcend.co.jp</a> <a href="http://www.transcend.jp">www.transcend.jp</a>
	<b>THE NETHERLANDS</b> E-mail: <a href="mailto:sales@transcend.nl">sales@transcend.nl</a> <a href="http://www.transcend.nl">www.transcend.nl</a>
	<b>United Kingdom</b> E-mail: <a href="mailto:sales@transcend-uk.com">sales@transcend-uk.com</a> <a href="http://www.transcend-uk.com">www.transcend-uk.com</a>
	<b>Korea</b> E-mail: <a href="mailto:sales@transcend.co.kr">sales@transcend.co.kr</a> <a href="http://www.transcend.co.kr">www.transcend.co.kr</a>