

3-phase diode bridge *plus* thyristor PGH series Power Module

PGH series power module includes 3-phase diode bridge and inrush current limiting thyristor in a package. This series are widely applied to rectification circuit in popular 3-phase inverters. This paper shows how to use PGH series, and also

covers information on 3-phase rectification circuit, driver circuit, and selection of heatsink. In addition, it provides designers, who are not very familiar with thyristor, with its basic application information.

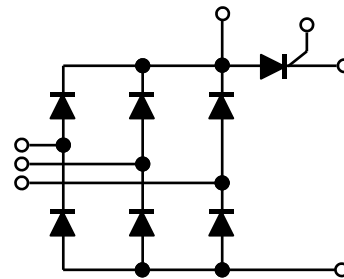
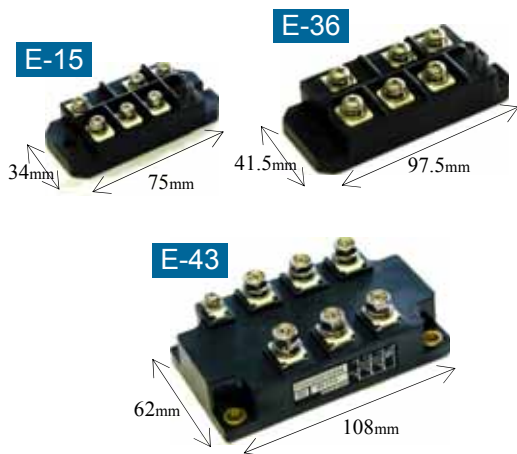

PGH series

PGH series Packages

List of PGH series

Part Number	$I_{T(AV)}, I_{F(AV)}$ (A)	V_{DRM}, V_{RRM} (V)	Case Outline
PGH308	30	800	E-15
PGH3016AM	30	1600	E-36
PGH508AM	50	800	E-36
PGH5016AM	50	1600	E-36
PGH758AM	75	800	E-36
PGH7516AM	75	1600	E-36
PGH1008AM	100	800	E-36
PGH10016AM	100	1600	E-36
PGH1508AM	150	800	E-43
PGH15016AM	150	1600	E-43
PGH2008AM	200	800	E-43
PGH20016AM	200	1600	E-43

Power modules must be installed on heatsink. And, unless proper cares are taken, reliability problem or failure would possibly occur. Firstly, precautions on assemble are shown for your reference.

●Mounting to Heatsink

- Mounting surface of heatsink should be free from burrs, intrusions and indentations, thus it should have enough flatness.
- Before mounting, remove blemish and foreign material on both surfaces of device and heatsink.

And, apply thermal compounds (Shinetsu G746 is recommended) thinly and evenly. Also, be careful not to spread grease to screw.

- Be sure not to exceed rated fastening torque.

●Tightening screws

•To mount module with multiple screw holes, firstly, tighten loosely all the screws. After that, fully tighten all the screws up to the specified torque. Rough estimate for tentative tightening is that spring washer is forced to be pressed lightly. Tightening sequence is shown below.



Sequence of tightening screws

●3-phase AC-DC converter and PGH series

Three-phase full-wave rectifiers are generally used in high power inverters for AC-DC conversion. Unless charging current during switch-on period is not limited, life of electrolytic capacitor becomes to be significantly short.

thyristor would be more suitable choice for this usage. The PGH type modules have three-phase diode bridge and one thyristor in a package, and, as expected, these are the best to this application. For comparatively small power supply like PC power, NTC thermistors are widely applied, but, in high power field, we recommend our PGH type modules.

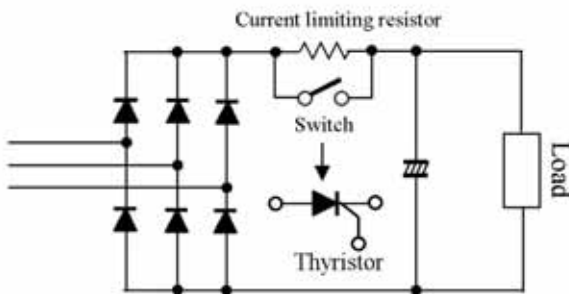

Three phase full-wave AC DC converter including rush current limiting function

This is three phase AC DC converter including inrush current limiting function. The resistor limits inrush current, and it is shorted via switch after transitional period during which capacitor is charging. Although mechanical relay is used as this switch, if life of contact would be considered,

●3-phase full-wave rectifier

On the next page, you will find a table that shows the relationships among peak, average and RMS of alternative input, DC output, and diode current in three phase full-wave rectifier. This table will be a useful reference to select diode and other components. In addition, information on single-phase circuit is also indicated in the table.

The peak reverse voltage applied to diode in PGH module is 2.45 times phase voltage in three-phase rectifier. Actually, the peak voltage to diode is 490V for three phase 200V line, and 980V for 400V line.

● Required voltage rating of diode and thyristor depending on AC line voltage, and Line filter

AC line voltage and PGH series lineup are as

Rectification circuit					
Each diode (Resistive load)	Average current	I_{dAVG}	$0.5 I_{dAVG}$	$0.5 I_{dAVG}$	$0.333 I_{dAVG}$
	RMS current	$1.57 I_{dAVG}$	$0.785 I_{dAVG}$	$0.785 I_{dAVG}$	$0.579 I_{dAVG}$
	Peak current	$3.14 I_{dAVG}$	$1.57 I_{dAVG}$	$1.57 I_{dAVG}$	$1.05 I_{dAVG}$
Each diode (Inductive load)	Average current		$0.5 I_{dAVG}$	$0.5 I_{dAVG}$	$0.333 I_{dAVG}$
	RMS current		$0.707 I_{dAVG}$	$0.707 I_{dAVG}$	$0.578 I_{dAVG}$
	Peak current		I_{dAVG}	I_{dAVG}	I_{dAVG}
Peak reverse voltage to Diode	$1.41 e_{RMS}$	$2.82 e_{RMS}$	$1.41 e_{RMS}$	$2.45 e_{RMS}$	
DC output voltage Peak / Average	3.14	1.57	1.57	1.05	
AC input voltage Line voltage/Phase Voltage		2		1.73	
AC input voltage RMS / Average	2.22	1.11	1.11	0.428	

Table 1 Constants of rectification circuits

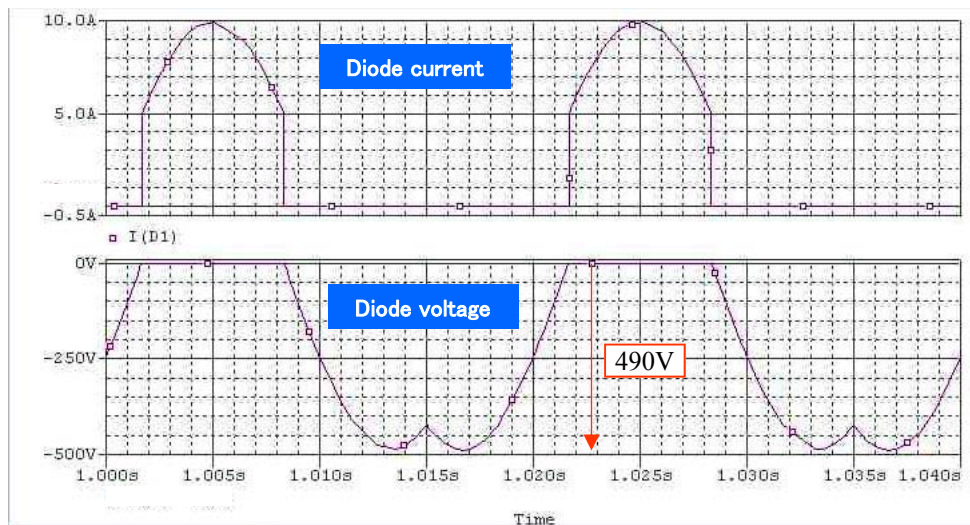
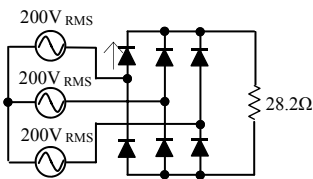

An example of diode current and voltage in three phase full-wave rectification circuit

follows.

For AC200V line: V_{DRM} and V_{RRM} : 800V
 For AC400V line: V_{DRM} and V_{RRM} : 1,600V

Between AC line and bridge rectifier, use appropriate AC line filter. It reduces the noise entering into the equipment not so as to cause any undesired behaviors. Furthermore, it suppresses conducted emission from the equipment. As are expected, external stresses on diode and thyristor, such as surge voltage and current, can be decreased by such filter.

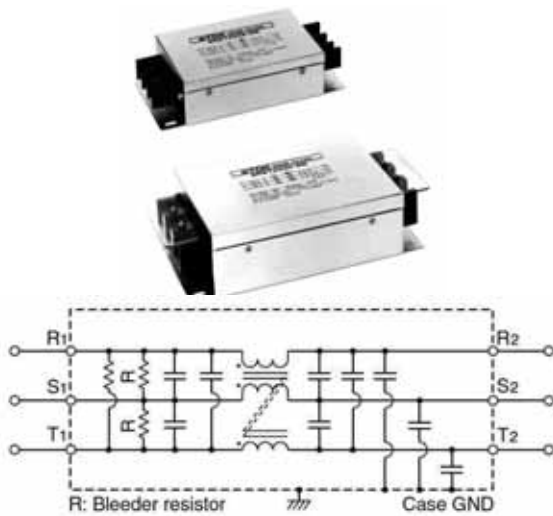

TDK 3-phase line filter and internal diagram

● Thyristor

1, What's thyristor

Thyristor is considered as a diode and a switch connected in serial.

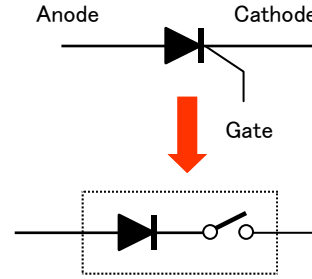

Thyristor

Same as bipolar transistor, thyristor is driven by current. With respect to bipolar transistor, when base current is applied, collector current of h_{FE} times base current flows. In contrast, thyristor is switched on by gate current that is higher than a specific value (gate trigger current). The following figure illustrates these relationships. You will see that collector current of bipolar transistor flows during the whole period when base current flows, but thyristor keeps anode current flowing even after the gate current is cut off. So, you need not supply thyristor with continuous gate current

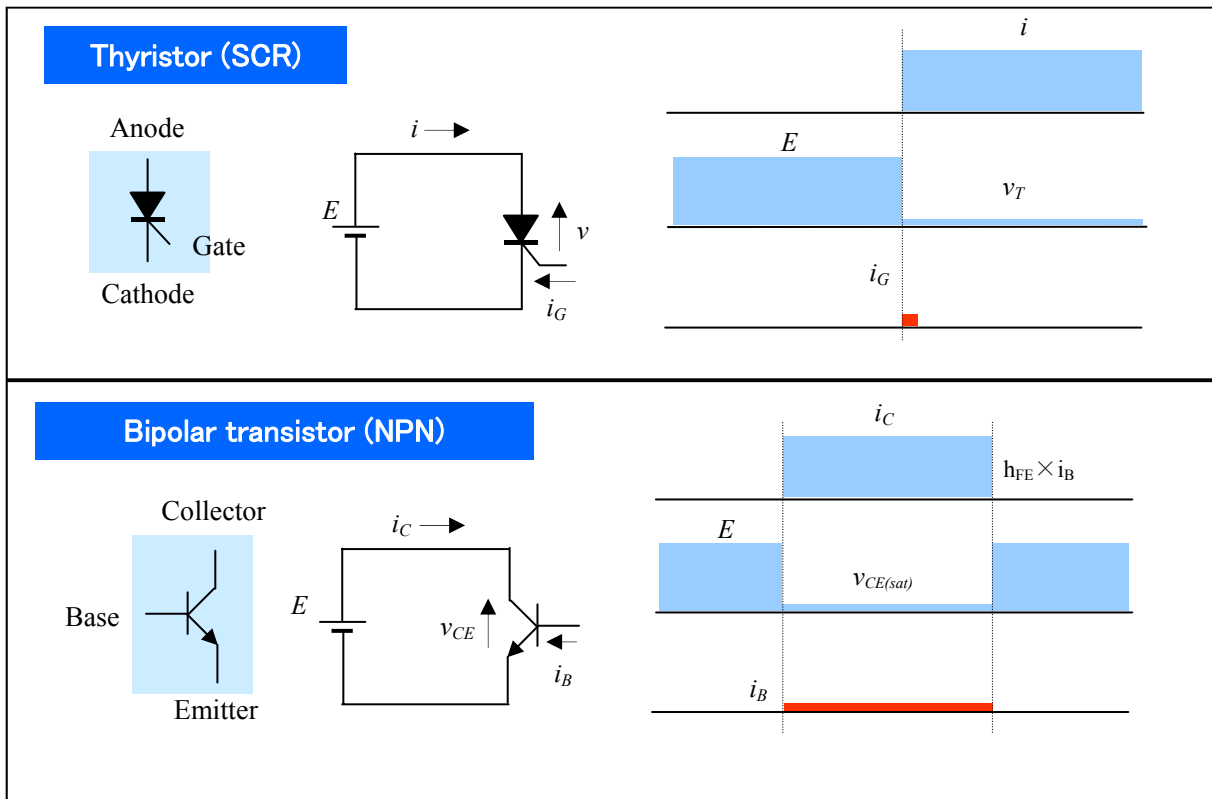

during all of the on-period. At present, major switching devices, such as MOSFET and IGBT, are driven by voltage, but thyristor is current-driven device. Please keep in mind this fact when you design gate firing circuit for thyristor.

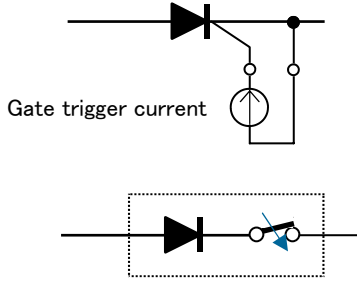

Gate current turns on Thyristor

2, Behaviors of Thyristor as a switch — Holding current, and Latching current

2-1, Holding current

Once thyristor turns on, the on-state is maintained as far as anode current is larger than a certain value. In other words, thyristor turns off when anode current decreases to a certain value. The “certain current” is the holding current, and that of PGH308 (30A 800V) is 70mA typical at 25°C. (Refer to individual datasheet.) Now, let's see the influence of holding current in an actual circuit.

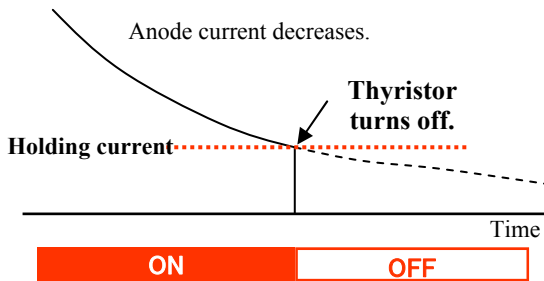

Holding current

Supposing that pulse trigger current is applied only once. Thyristor is turned on, however, if the load is resistive and anode-cathode voltage goes to zero, anode current altogether decreases to below holding current. After that, positive voltage would be applied to anode, however, thyristor maintains off-state so far as gate current would be applied again.

2-2. Latching current

Assume that, due to slow rise of anode current, the current doesn't reach a certain level before gate current is terminated, thyristor turns off. It follows that, after removal of gate current, the

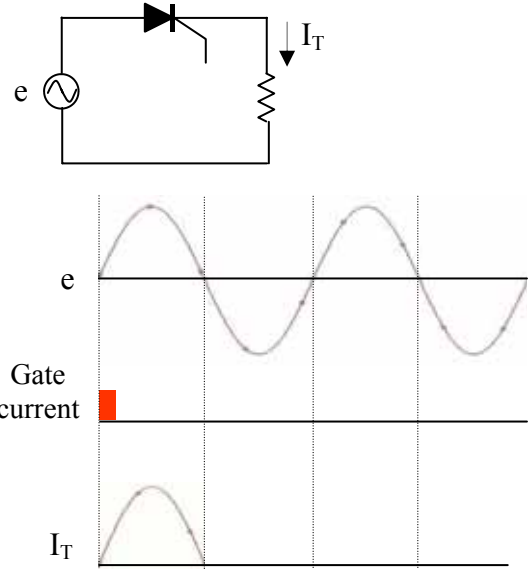

Thyristor turns off when anode current becomes below holding current.

minimum anode current which can maintain on-state is the latching current. For example, typical latching current of PGH308 (30A 800V) is 90mA (25°C).

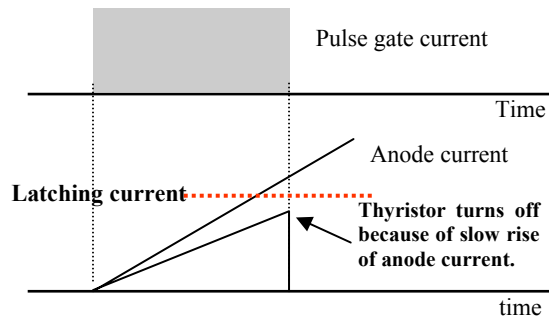

Latching current

If thyristor cannot be turned on or on-state may not be able to maintain, increase gate pulse width or try multiple gate pulses. Both holding current and latching current are temperature-dependent, and they become larger at low temperature. Compared with at 25°C, they are about twice larger at -40°C.

3, Gate drive

3-1 How to achieve sure turn-on

3-1-1 Temperature dependence of gate characteristics

In datasheet of PGH308, you will find a graph of gate characteristics like this.

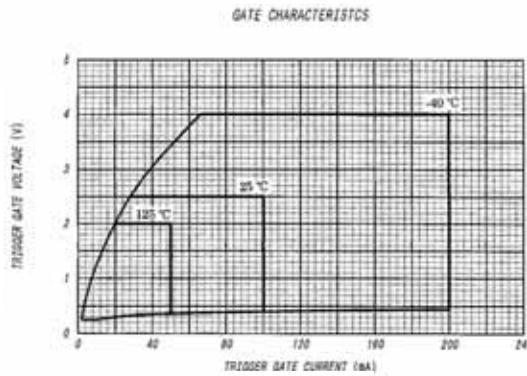

This graph shows required gate current and voltage to trigger all the PGH308 at -40°C, at 25°C and 125°C. For example, we know that DC current of 100mA can turn on every PGH308 at 25°C, and accompanied gate voltage is less than 2.5V.

Based on this graph, let us find out how large is the gate trigger current at a certain temperature, which comes from the lowest operating temperature of the equipment in which the thyristor will be installed. Trigger currents at -40, 25°C, and 125°C are plotted on the graph like below, and we can estimate that trigger current at -20°C is around 150mA.

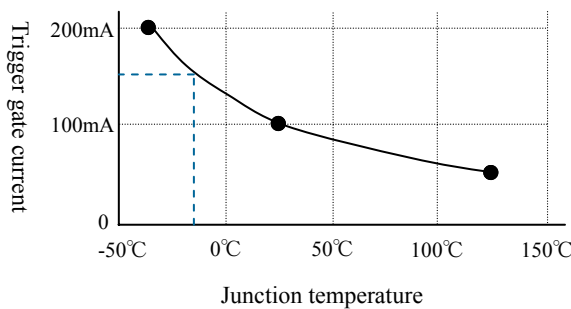

Temperature dependence of gate current

3-1-2 Pulse width dependence of gate trigger current

In case that pulse gate current is applied, and pulse width is shorter than 20μs, required gate current to turn on thyristor is large compared with DC. Furthermore, a remarkable increase in gate trigger current is needed when the pulse duration falls below 10 μs specifically. For example, pulse trigger current of 5μs width is twice larger than

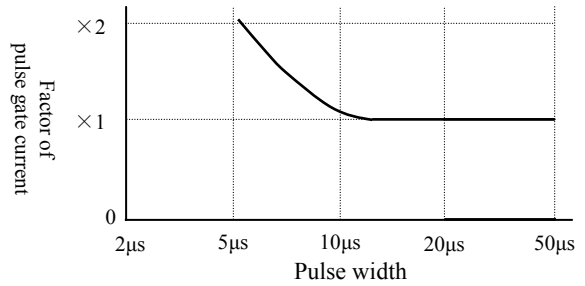

Typical pulse trigger current

DC. Assuming that the minimum operating temperature is -20°C and pulse width is 5μs, the estimated peak trigger current is 300mA (150mA × 2). Accordingly, combination of dependence in temperature and dependence in pulse width will give you how large is the required gate current to trigger.

3-2 Ratings of gate current, voltage, and power

Rating is the limit where stress on device may spoil its reliability significantly or cause catastrophic damage. As shown on the graph below, the three ratings - peak gate current, voltage, and power (gate current times gate voltage) - are defined. In addition, average gate power is also limited. For detailed information, refer to individual datasheet.

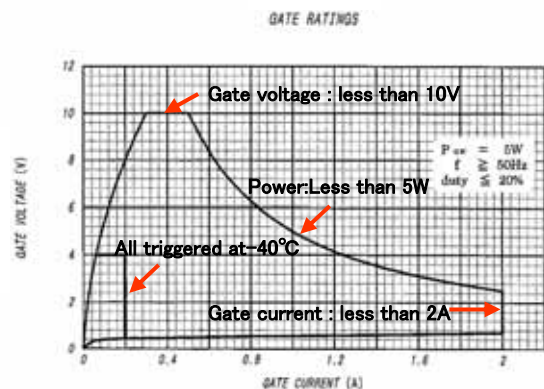

Gate ratings

To turns on thyristor firmly, gate current and gate voltage tend to become high. Be careful in average power for DC triggering, and in peak power for pulse triggering.

3-3 To avoid trigger by noise (To avoid malfunction)

The maximum gate voltage not to trigger is 0.25V (T_j = 125°C, 2/3 · V_{DRM}). This implies that more than 0.25V between gate and cathode may possibly turn on the thyristor.

In order to avoid unintended turn-on by noise (malfunction), such measures are expected to be effective.

*Connect cathode of trigger signal to the terminal ex-



clusive for trigger.

*Gate serial diode

Noise as high as diode forward voltage (approximately 0.7 V) is cancelled. However, the drive signal is cut by the voltage, and, if necessary, it should be compensated..

*Gate parallel diode

The diode may prevent an excessive gate reverse voltage.

*Gate parallel capacitor (0.01~0.1μF)

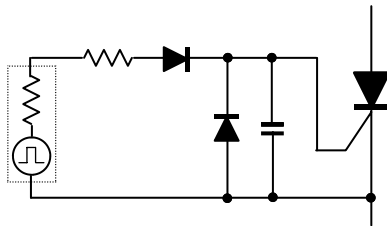

Measures to avoid gate malfunction

3-4 Gate load line

A gate load line is used to specify the power-supply voltage to gate trigger circuit, and current-limiting resistance (including power supply inter-

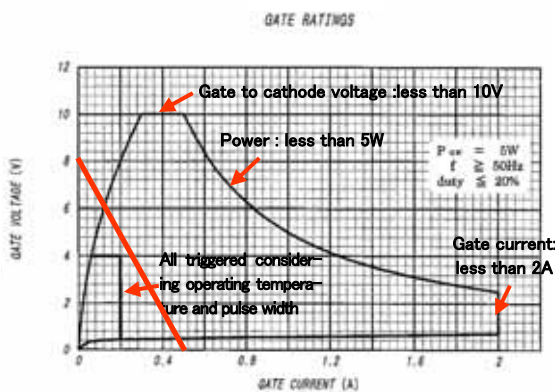

Gate load line

nal resistance). Accordingly, considering minimum operating temperature and width of triggering pulse, we can design gate driver that can turn-on every device, where drive current, voltage, and power are all well within the corresponding ratings.

As shown in the figure below, at first, plot open-circuit power-supply voltage of the gate trigger circuit on the voltage axis (vertical axis), and plot short-circuit current at the current axis (horizontal axis). Then, link these two points by straight line. This gate load line should exceed area that all devices can be triggered, and should also satisfy all the ratings - gate current, gate voltage, and gate power. In this example, short-circuit current is 0.5A, and open voltage is 8V. Therefore, we know that the current-limiting resistance is 16 Ω.

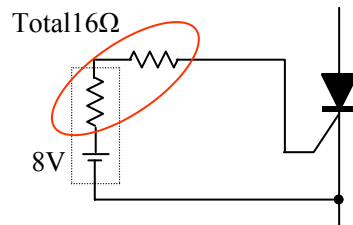

Design example of gate load line

The load line is a classical way of thinking. At present, we can easily realize constant-voltage or constant-current drivers. IGBT and MOSFET are driven by voltage, however, thyristor is driven by current. Consequently, when designing gate driver for thyristor, apply constant-current basis design.

Incidentally, reverse power loss of thyristor increases significantly in case of applying DC gate current while reverse voltage is applied to anode to cathode. Because reverse voltage isn't applied to PGH in standard applications, this fact is not meaningful. However, remember that it's an important nature of thyristor.

4, Thermal design (Choice of heatsink)

Including PGH, base plate of power module is generally made of copper. However, unless combined with heatsink, temperature rise is so

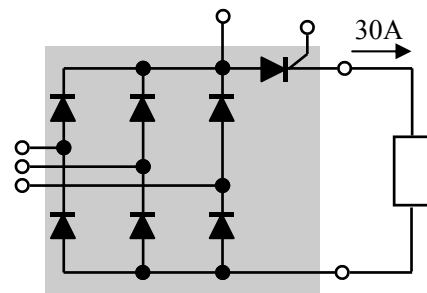

PGH508AM

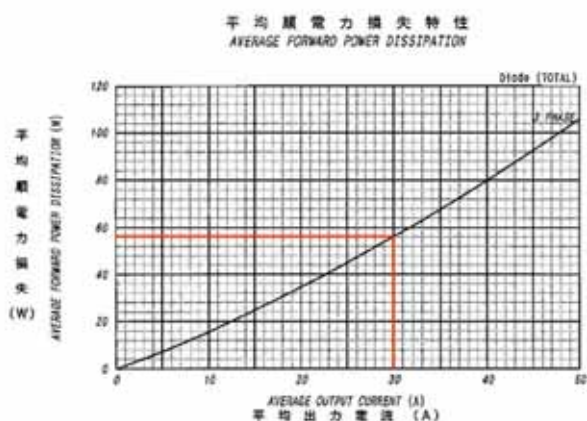

Diode average forward power dissipation
(6 diodes total)

high that it can carry only an extremely small current. As a result, appropriate heatsink is inevitable for power module to show practical current handling capability. And, again, apply thermal compound (Shinetsu silicon G746 or equivalent) uniformly and thinly to mounting surfaces of power module and heat sink. Supposing this, contact thermal resistance is prescribed.

Now, thermal design for PGH508AM to carry 30A is shown below. Thermal resistances (R_{th}) are defined as follows.

- Contact $R_{th}(c-f)$ $0.06^{\circ}\text{C}/\text{W}$
- Diode junction to case $R_{th}(j-c)$ $0.27^{\circ}\text{C}/\text{W}$
- Thyristor junction to case $R_{th}(j-c)$ $0.8^{\circ}\text{C}/\text{W}$

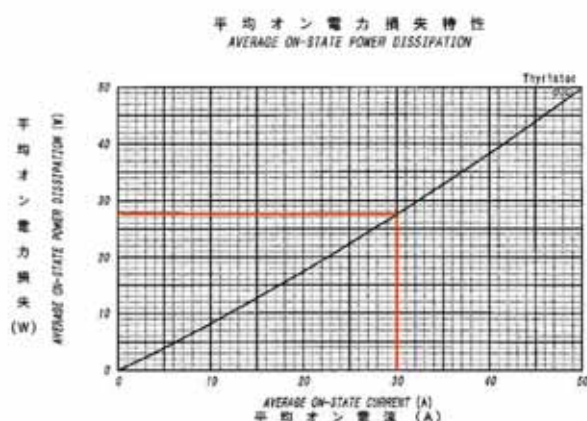

Thyristor average on-state power dissipation

Upper graphs show the power dissipations of diode and thyristor as follows.

- Diode (6 diodes total) 56W
- Thyristor 27.5W

Dissipation of diode is that of 6 diodes total, and thermal resistance is defined corresponding to this situation.

Followings show graphical explanation how to calculate temperature rise.

Junction temperature rise referred to case temperature

- Thyristor $R_{th}(j-c)=0.8^{\circ}\text{C}/\text{W}$
- Diode $R_{th}(j-c)=0.27^{\circ}\text{C}/\text{W}$



Temperature difference between junction and case	
Diode	Thyristor
15.1°C (56×0.27)	22°C (27.5×0.8)

Case temperature rise referred to Ambient temperature and Fin temperature

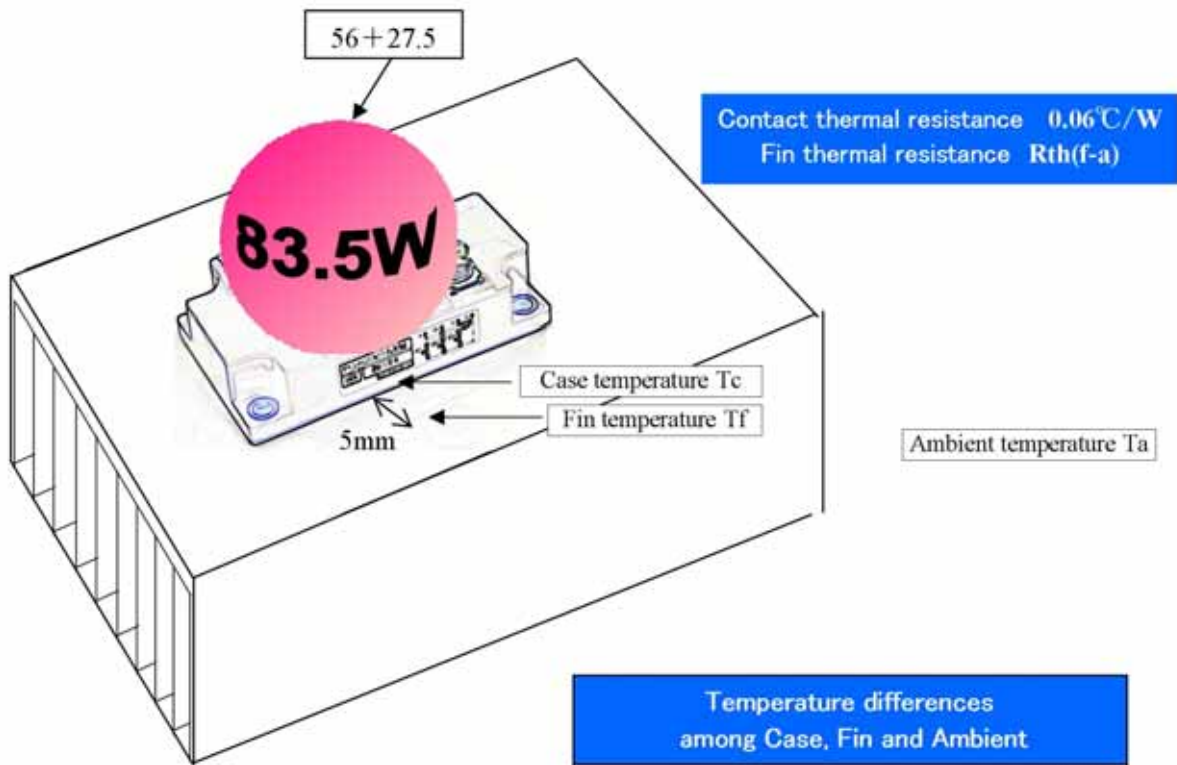

Temperature differences among Case, Fin and Ambient	
$T_c - T_f$	$0.06 \times 83.5 = 5.0 (^{\circ}\text{C})$
$T_f - T_a$	$R_{th}(f-a) \times 83.5$

Consequently, temperature difference between junction and fin is as follows.

- Diode $15.1 + 5 = 20.1 (^{\circ}\text{C})$
- Thyristor $22 + 5 = 27 (^{\circ}\text{C})$

The temperature rise of thyristor is higher than that of diode, and we will focus on thyristor. Since its maximum junction temperature is 150°C , we can conclude that maximum allowable fin temperature is 123°C ($150^{\circ}\text{C} - 27^{\circ}\text{C}$).

$$T_f - T_a = R_{th}(f-a) \times 83.5$$

Assuming that maximum ambient temperature is 50°C , we can calculate the highest limit of fin thermal resistance as follows.

$$R_{th}(f-a) \leq (123 - 50) / 83.5 = 0.87 (^{\circ}\text{C}/\text{W})$$

Here, specific device (PGH508AM) under specific operating condition (Output current: 30A, $T_a: 50^{\circ}\text{C}$) was discussed, and we calculated the required fin (heatsink) thermal resistance. In other situations, refer to this example and obtain an appropriate heat sink corresponding to the device and to the operating condition.

5, Surge on-state current, I^2t , di/dt , dv/dt

Thyristor in PGH module is generally free from these ratings and characteristics, however, data-sheet includes these items which are intrinsic to thyristor. For your reference, these are explained briefly.

5-1 Surge on-state current, I^2t , Critical rate of rise of turn-on current di/dt

These are ratings, and these indicate the limit whether device may encounter catastrophic failure or not. Since each is non-repetitive rating, only once of such stress may result in destruction or significant deterioration in reliability.

It is the surge on-state current that prescribes destructive current of 50Hz (or 60Hz) sinusoidal half-wave, and pulse width is 10ms (or 8.3 ms). In regard to graph of surge on-state current, horizontal axis shows the time from 0.02 ms (1pulse) to 2sec (100 pulses), and vertical axis shows the peak value of surge on-state current.

Based on surge on-state current of 1 pulse (10ms), I^2t defines current tolerance between 2ms

and 10ms. Here, the I is RMS current. Assuming that 1 pulse surge on-state current is 600A, I^2t can be calculated as follows.

$$(600/\sqrt{2})^2 \times 0.01 = 1,800A^2s$$

This figure is useful when thyristor is protected by (cutting) fuse. There is a similar regulation in fuse, too, so we can choose a matched pair where thyristor doesn't fail but fuse is broken.

Critical rate of rise of turn-on current di/dt defines how large is the destructive limit below 2ms. After gate current is applied, it takes about 100 μ s before all the area of thyristor turns into on-state. In other words, if pulse width of current is very short, partial conduction occurs. As a result, small area owes the power, and power density in the area also becomes very high.

It is the di/dt that, for such reason, prescribes the rating against sharp rising current pulse.

These three current rating are represented on common time axis as follows.

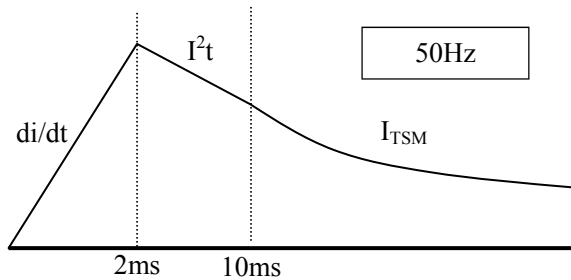

At present, we don't worry whether major power switching devices, such as MOSFET or IGBT, would withstand starting-up current or not even if how fast it is. This is because very small unit-cells are accumulated in one chip, and their high frequency characteristics are remarkably excellent compared with thyristor. By contrast, general thyristor is made of single thyristor unit. Therefore, on-region begins from neighborhood area of gate, and it spreads to the whole chip with time.

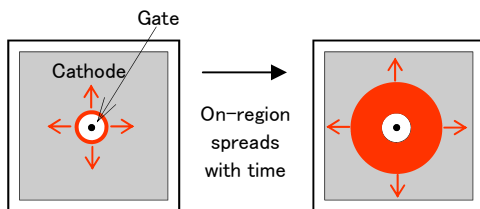

On-region spread of Thyristor chip

If critical rate-of-rise of on-state current di/dt is 100A/ μ s, for example, thyristor may fail when anode current reaches more than 100A at 1 μ s,

200A at 2 μ s, ... after turn-on (after gate current begins to flow). The initial turned-on area depends on gate drive current. The faster and the larger on-gate is, the larger initial turn-on area is. For that reason, faster and larger gate current, such as $i_G=200mA$ and $di_G/dt=0.2A/\mu s$, is specified as standard condition for di/dt for a thyristor that has maximum trigger gate current of 50mA at 25 °C.

When high di/dt is anticipated, additional reactor in the anode current loop is effective to suppress di/dt . Additionally, enough large and sharp on-gate current within gate ratings, is also valid to improve di/dt capability of thyristor itself.

5-2 Critical rate of rise of off-state voltage dv/dt

As explained, thyristor is normally turned on by gate current. However, it may be also turned on by high dv/dt of anode voltage. It is the critical rate of rise of off-state voltage dv/dt , which prescribes the limit of rising. Displacement current into inner capacitance of thyristor chip has similar effect to gate current.

The dv/dt is a typical cause of thyristor malfunctions. Thyristor chips which have dv/dt capability of 100V/ μ s or more have internal resistance that can bypass displacement current. Countermeasures against malfunction by dv/dt include application of thyristor that has higher dv/dt capability, addition of RCD to gate circuit same as for noise, and controlling dv/dt itself by CR snubber.

