

Eight Channel *ActivePath*TM Power Management IC

FEATURES

- Eight Functions Integrated Into One Package:
 - *ActivePath*TM Li+ Charger and System Power Selection
 - 1.3A High Efficiency Step-Down DC/DC
 - 1.0A High Efficiency Step-Down DC/DC
 - 0.55A High Efficiency Step-Down DC/DC
 - 360mA Low Noise, High PSRR LDOs
 - 360mA Low Noise, High PSRR LDOs
 - 30mA RTC LDO/Backup Battery Charger
- I²CTM Serial Interface
- Minimal External Components
- Compatible with USB or AC-Adapter Charging
- 5mm × 5mm, Thin-QFN (TQFN55-40) Package
 - Only 0.75mm Height, RoHS Compliant

APPLICATIONS

- Personal Navigation Devices
- Portable Media Players
- Smart Phones

GENERAL DESCRIPTION

The patent-pending ACT8810 is a complete, cost effective, highly-efficient *ActivePMU*TM power management solution that is ideal for a wide range of high performance portable handheld applications such as personal navigation devices (PNDs). This device integrates the *ActivePath*TM complete battery charging and management system with six power supply channels.

The *ActivePath* architecture automatically selects the best available input supply for the system. If the external input source is not present or the system load current is more than the input source can provide, the *ActivePath* supplies additional current from the battery to the system. The charger is a complete, thermally-regulated, stand-alone single-cell linear Li+ charger that incorporates an internal power MOSFET.

REG1, REG2, and REG3 are three independent, fixed-frequency, current-mode step-down DC/DC converters that output 1.3A, 1.0A, and 0.55A, respectively. REG4 and REG5 are high performance, low-noise, low-dropout linear regulators that output up to 360mA each. REG6 is a RTC LDO that outputs up to 30mA for a real time clock. Finally, an I²C serial interface provides programmability for the DC/DC converters and LDOs.

Tiny 5mm × 5mm 40-pin Thin-QFN package that is just 0.75mm thin.

SYSTEM BLOCK DIAGRAM

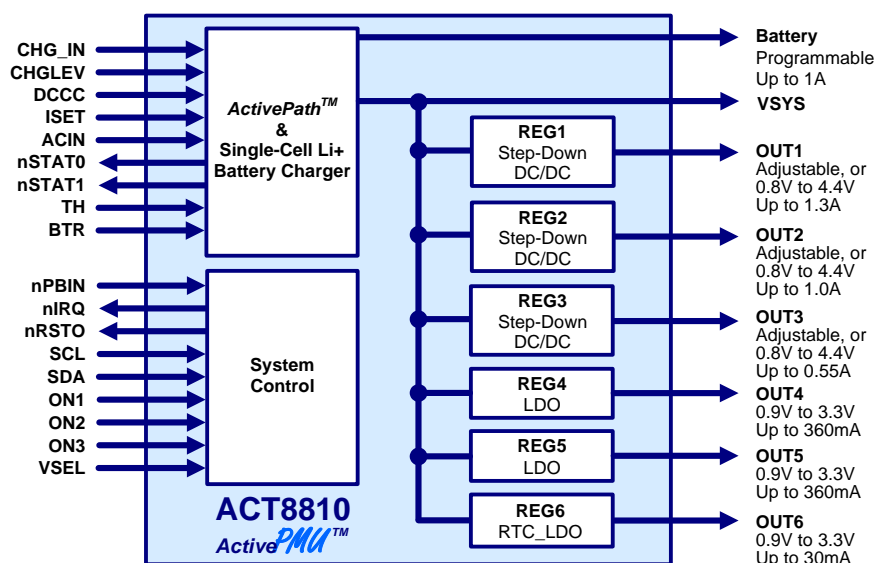

PRODUCT OPTIONS

Block	Function	Output Voltage ^①	Capability ^②
ActivePath	System Power Selection	4.6V	Up to 2.4A
CHGR	Battery Charger	4.20V (4.10V to 4.30V available)	Programmable up to 1A
REG1	Step-Down DC/DC	Adjustable, or 0.8V to 4.4V	1.3A
REG2	Step-Down DC/DC		1.0A
REG3	Step-Down DC/DC		0.55A
REG4	LDO	0.9V to 3.3V	360mA
REG5	LDO		360mA
REG6	RTC LDO		30mA

①: Output voltage options detailed in this table represent standard voltage options, and are available for samples or production orders. Contact Active-Semi for more information regarding semi-custom output voltage combinations.

②: Contact factory for additional available products or custom requirements.

FUNCTIONAL BLOCK DIAGRAM

