

Silicon PNP Power Transistors

2N5597 2N5599 2N5601 2N5603

DESCRIPTION

- With TO-66 package
- Excellent safe operating area
- Low collector saturation voltage

APPLICATIONS

- For high frequency power amplifier ; audio power amplifier and drivers.

PINNING(see Fig.2)

PIN	DESCRIPTION
1	Base
2	Emitter
3	Collector

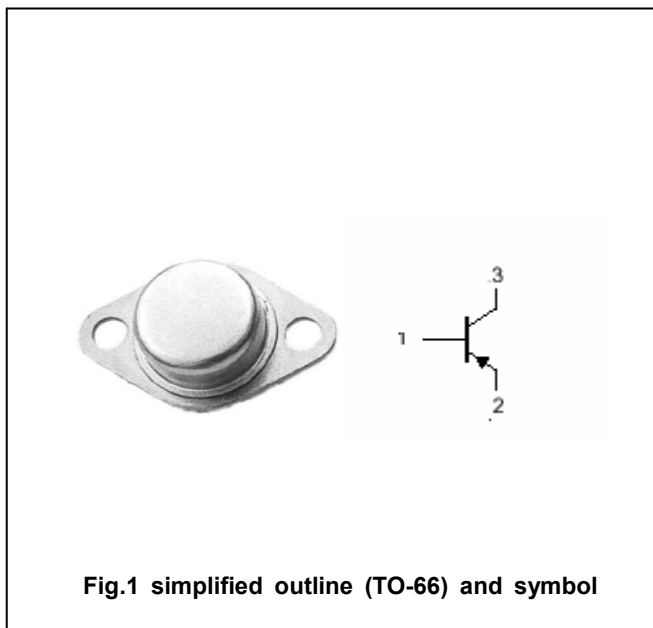

Fig.1 simplified outline (TO-66) and symbol

Absolute maximum ratings(Ta=□)

SYMBOL	PARAMETER	CONDITIONS	VALUE	UNIT
V _{CBO}	Collector-base voltage	2N5597	-80	V
		2N5599/5601	-100	
		2N5603	-120	
V _{CEO}	Collector-emitter voltage	2N5597	-60	V
		2N5599/5601	-80	
		2N5603	-100	
V _{EBO}	Emitter-base voltage	Open collector	-5	V
I _C	Collector current		-2	A
P _D	Total power dissipation	T _C =25□	20	W
T _j	Junction temperature		150	□
T _{stg}	Storage temperature		-65~150	□

THERMAL CHARACTERISTICS

SYMBOL	PARAMETER	VALUE	UNIT
R _{th j-c}	Thermal resistance junction to case	4.37	□/W

Silicon PNP Power Transistors 2N5597 2N5599 2N5601 2N5603

CHARACTERISTICST_j=25 °C unless otherwise specified

SYMBOL	PARAMETER		CONDITIONS	MIN	TYP.	MAX	UNIT
V _{CEO(SUS)}	Collector-emitter sustaining voltage	2N5597	I _C =-50mA ; I _B =0	-60			V
		2N5599/5601		-80			
		2N5603		-100			
V _{CEsat}	Collector-emitter saturation voltage		I _C =-1A; I _B =-0.1A			-1.0	V
V _{BE}	Base-emitter on voltage		I _C =-1A ; V _{CE} =-5V			-1.5	V
I _{CBO}	Collector cut-off current		V _{CB} =Rated V _{CBO} ; I _E =0			-0.1	mA
I _{CEO}	Collector cut-off current		V _{CE} = Rated V _{CEO} , I _B =0			-1.0	mA
I _{EBO}	Emitter cut-off current		V _{EB} =-5V; I _C =0			-0.1	mA
h _{FE}	DC current gain	2N5597/5601	I _C =-1A ; V _{CE} =-5V	70		200	
		2N5599/5603		30		90	
f _T	Transition frequency	2N5597/5601	I _C =-0.5A ; V _{CE} =-10V	60			MHz
		2N5599/5603		50			

Silicon PNP Power Transistors 2N5597 2N5599 2N5601 2N5603

PACKAGE OUTLINE

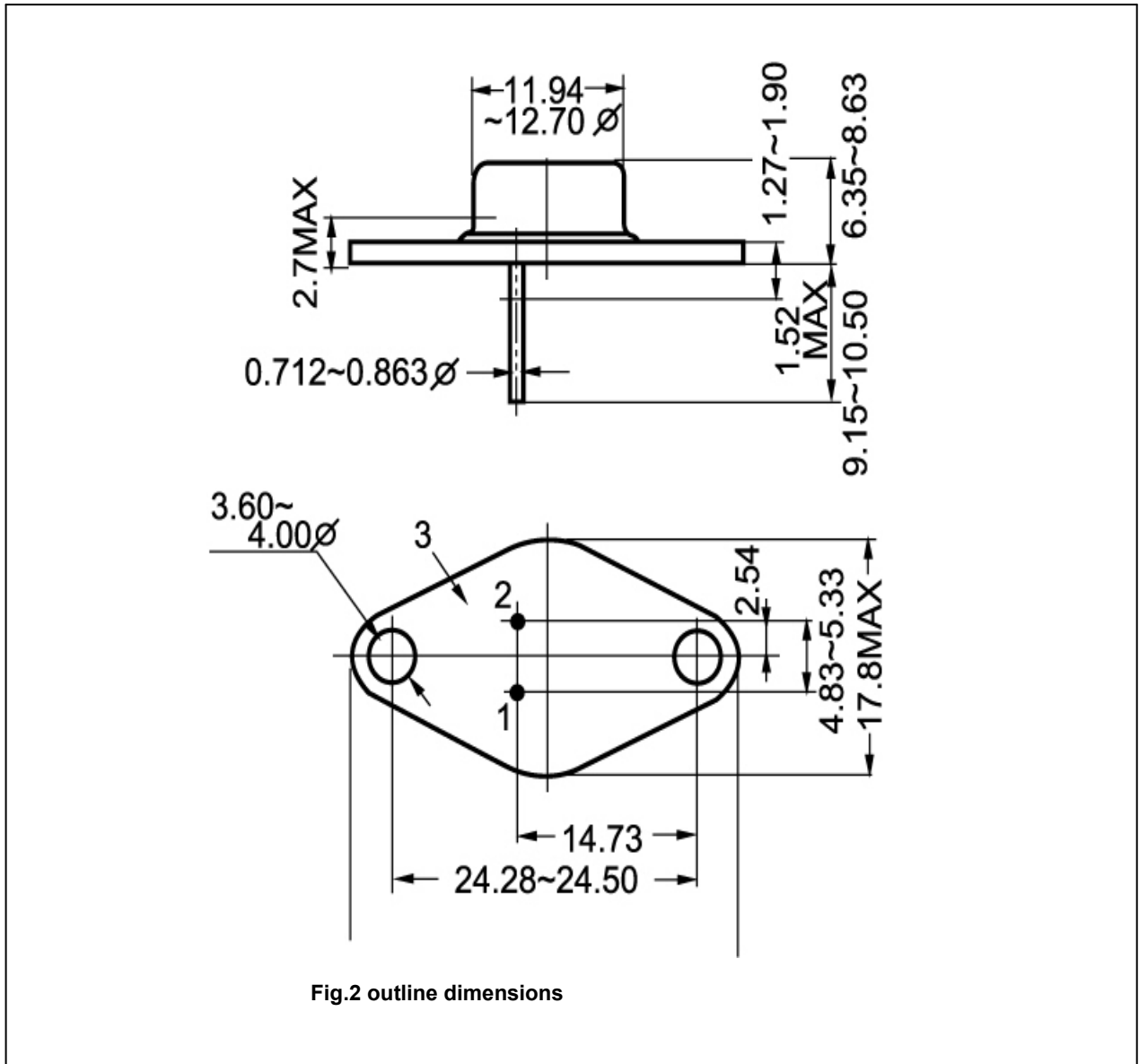

Fig.2 outline dimensions