

Power Inductor CDRH**D**R Series



■ Features

- ◎ Magnetically shielded construction.
- ◎ Storage temperature range: -40°C~+105°C.
- ◎ Operating temperature range: -40°C~+105°C(including coil's self-heat).
- ◎ Competitive price due to improvement of productivity efficiency.
- ◎ RoHS Compliance.

■ Applications

Ideally used in Mobile phone,PDA,MP3,DSC/DVC,HDD,etc as DC-DC converter inductors.

■ Shapes and Dimensions/Recommended Land Patterns(mm)

◆ Dimensions

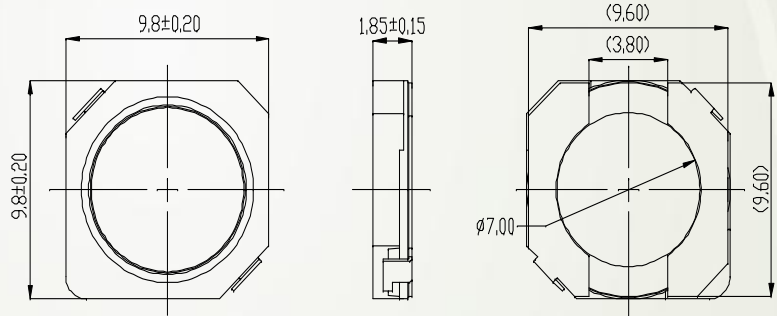

CDRH98D18R

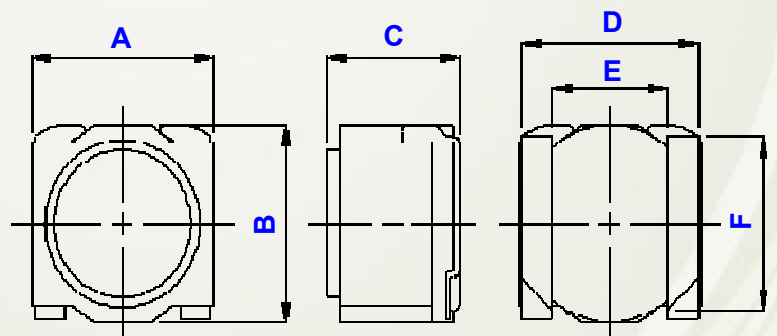

Type name	A Max.	B Max.	C Max.	D	E	F
CDRH50D28R	5.3	5.3	3.0	4.8	3.2	4.2
CDRH50D43R	5.3	5.3	4.5	4.8	3.2	4.2
CDRH60D28R	6.3	6.3	3.0	5.8	3.8	5.3
CDRH60D43R	6.3	6.3	4.5	5.8	3.8	5.3

Power Inductor CDRH**D**R Series

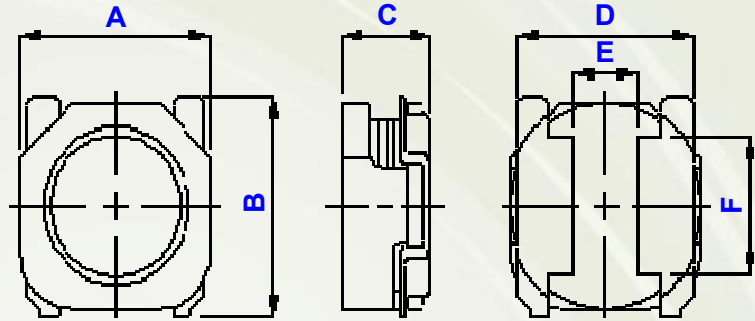

Type name	A Max.	B Max.	C Max.	D	E	F
CDRH30D14R	3.15	3.3	1.5	2.8	1.0	2.0
CDRH30D16R	3.15	3.3	1.8	2.8	1.0	2.0
CDRH38D14R	3.95	4.2	1.5	3.5	1.0	3.0
CDRH38D14R/HP	3.95	4.2	1.5	3.5	1.0	3.0
CDRH38D14R/LD	3.95	4.2	1.5	3.5	1.0	3.0
CDRH38D16R	3.95	4.2	1.8	3.5	1.0	3.0
CDRH38D16R/HP	3.95	4.2	1.8	3.5	1.0	3.0
CDRH38D16R/LD	3.95	4.2	1.8	3.5	1.0	3.0

◆ Land pattern (mm)

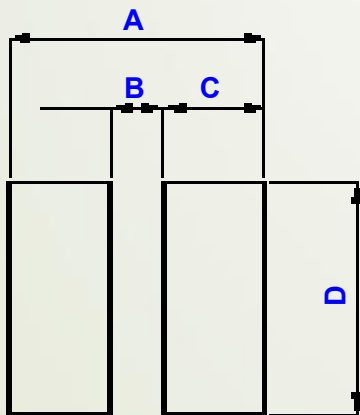

Type Name	A	B	C	D
CDRH30D14R	3.0	0.8	1.1	2.2
CDRH30D16R	3.0	0.8	1.1	2.2
CDRH38D14R	3.8	0.8	1.5	3.2
CDRH38D14R/HP	3.8	0.8	1.5	3.2
CDRH38D14R/LD	3.8	0.8	1.5	3.2
CDRH38D16R	3.8	0.8	1.5	3.2
CDRH38D16R/HP	3.8	0.8	1.5	3.2
CDRH38D16R/LD	3.8	0.8	1.5	3.2
CDRH50D28R	5.2	3.0	1.1	4.8
CDRH50D43R	5.2	3.0	1.1	4.8
CDRH60D28R	6.2	3.6	1.3	5.9
CDRH60D43R	6.2	3.6	1.3	5.9
CDRH89D18R	10.2	3.6	3.3	10.2

Power Inductor CDRH**D**R Series



■ Electrical Characteristics specification.

◆ CDRH30D14R

Sumida P/N	Inductance (μH)	D.C.R. ($\text{m}\Omega$)	Saturation Current (A) ※1		Temperature Rise Current (A) ※2
			(at 20°C)	(at 100°C)	
CDRH30D14RNP-1R0NC	1.0 \pm 30%	39 \pm 25%	1.90	1.40	2.43
CDRH30D14RNP-1R4NC	1.4 \pm 30%	50 \pm 25%	1.60	1.20	2.10
CDRH30D14RNP-2R2NC	2.2 \pm 30%	74 \pm 25%	1.30	1.00	1.62
CDRH30D14RNP-3R3MC	3.3 \pm 20%	111 \pm 20%	1.05	0.80	1.28
CDRH30D14RNP-4R7MC	4.7 \pm 20%	153 \pm 20%	0.90	0.68	1.16
CDRH30D14RNP-6R4MC	6.4 \pm 20%	223 \pm 20%	0.75	0.56	0.95
CDRH30D14RNP-100MC	10 \pm 20%	394 \pm 20%	0.60	0.46	0.63

◆ CDRH30D16R

Sumida P/N	Inductance (μH)	D.C.R. ($\text{m}\Omega$) Max. (Typ.)	Saturation Current (A) ※1	Temperature Rise Current (A) ※2
CDRH30D16RNP-1R0NC	1.0 \pm 30%	37.5(30)	1.88	2.73
CDRH30D16RNP-1R5NC	1.5 \pm 30%	47.5(38)	1.52	2.30
CDRH30D16RNP-2R2NC	2.2 \pm 30%	58.8(47)	1.28	1.95
CDRH30D16RNP-3R3MC	3.3 \pm 30%	93.8(75)	1.05	1.52
CDRH30D16RNP-4R7MC	4.7 \pm 30%	150(120)	0.88	1.11
CDRH30D16RNP-6R8MC	6.8 \pm 20%	210(175)	0.74	0.97
CDRH30D16RNP-100MC	10 \pm 20%	252(210)	0.60	0.86
CDRH30D16RNP-150MC	15 \pm 20%	498(415)	0.50	0.56
CDRH30D16RNP-220MC	22 \pm 20%	624(520)	0.41	0.52
CDRH30D16RNP-330MC	33 \pm 20%	948(770)	0.33	0.39

Power Inductor CDRH**D**R Series



◆ CDRH38D14R

Sumida P/N	Inductance (μH)	D.C.R. (mΩ) Max. (Typ.)	Saturation Current (A) ※1	Temperature Rise Current (A) ※2
CDRH38D14RNP-1R2NC	1.2±30%	28.8(23)	1.88	3.60
CDRH38D14RNP-1R6NC	1.6±30%	40(32)	1.64	3.00
CDRH38D14RNP-2R2NC	2.2±30%	55(44)	1.40	2.50
CDRH38D14RNP-3R3MC	3.3±20%	90(72)	1.12	1.90
CDRH38D14RNP-4R2MC	4.2±20%	114(91)	1.00	1.55
CDRH38D14RNP-6R8MC	6.8±20%	163(136)	0.80	1.32
CDRH38D14RNP-100MC	10±20%	270(225)	0.66	0.95
CDRH38D14RNP-150MC	15±20%	402(335)	0.53	0.76
CDRH38D14RNP-220MC	22±20%	642(535)	0.43	0.60
CDRH38D14RNP-330MC	33±20%	972(810)	0.36	0.48

◆ CDRH38D14R/HP

Sumida P/N	Inductance (μH)	D.C.R. (mΩ) Max. (Typ.)	Saturation Current (A) ※1	Temperature Rise Current (A) ※2
CDRH38D14RHPNP-R90NC	0.9±30%	25(20)	2.75	4.30
CDRH38D14RHPNP-1R2NC	1.2±30%	37.5(30)	2.40	3.40
CDRH38D14RHPNP-1R7NC	1.7±30%	53.8(43)	2.00	2.70
CDRH38D14RHPNP-2R2NC	2.2±30%	68.8(55)	1.80	2.40
CDRH38D14RHPNP-3R6MC	3.6±20%	113(90)	1.40	1.70
CDRH38D14RHPNP-4R3MC	4.3±20%	138(115)	1.28	1.45
CDRH38D14RHPNP-6R3MC	6.3±20%	222(185)	1.05	1.04
CDRH38D14RHPNP-100MC	10±20%	348(290)	0.83	0.83
CDRH38D14RHPNP-150MC	15±20%	552(460)	0.68	0.66
CDRH38D14RHPNP-220MC	22±20%	840(700)	0.56	0.54

Power Inductor CDRH**D**R Series



◆ CDRH38D14R/LD

Sumida P/N	Inductance (μH)	D.C.R. (mΩ) Max. (Typ.)	Saturation Current (A) ※1	Temperature Rise Current (A) ※2
CDRH38D14RLDNP-1R2NC	1.2±30%	27.5(22)	1.20	3.58
CDRH38D14RLDNP-1R5NC	1.5±30%	32.5(26)	1.08	3.30
CDRH38D14RLDNP-2R2NC	2.2±30%	43.8(35)	0.92	2.65
CDRH38D14RLDNP-3R3MC	3.3±20%	72.5(58)	0.76	2.14
CDRH38D14RLDNP-4R7MC	4.7±20%	90(72)	0.64	1.73
CDRH38D14RLDNP-6R8MC	6.8±20%	130(108)	0.54	1.46
CDRH38D14RLDNP-100MC	10±20%	214(178)	0.43	1.08
CDRH38D14RLDNP-150MC	15±20%	294(245)	0.35	0.85
CDRH38D14RLDNP-220MC	22±20%	480(400)	0.30	0.68
CDRH38D14RLDNP-330MC	33±20%	840(700)	0.24	0.48
CDRH38D14RLDNP-470MC	47±20%	1070(895)	0.21	0.44

◆ CDRH38D16R

Sumida P/N	Inductance (μH)	D.C.R. (mΩ)	Saturation Current (A) ※1		Temperature Rise Current (A) ※2
			(at 20°C)	(at 100°C)	
CDRH38D16RNP-R90NC	0.9±30%	19±25%	2.18	1.73	3.45
CDRH38D16RNP-1R6NC	1.6±30%	27±25%	1.65	1.39	3.05
CDRH38D16RNP-2R2NC	2.2±30%	30±25%	1.41	1.22	2.85
CDRH38D16RNP-3R3MC	3.3±20%	47±25%	1.16	0.99	2.25
CDRH38D16RNP-4R7MC	4.7±20%	68±25%	0.95	0.80	1.75
CDRH38D16RNP-6R8MC	6.8±20%	91±25%	0.81	0.69	1.50
CDRH38D16RNP-100MC	10±20%	127±20%	0.62	0.54	1.30
CDRH38D16RNP-150MC	15±20%	174±20%	0.53	0.47	1.15
CDRH38D16RNP-220MC	22±20%	303±20%	0.44	0.38	0.80
CDRH38D16RNP-330MC	33±20%	431±20%	0.35	0.31	0.68
CDRH38D16RNP-470MC	47±20%	788±20%	0.29	0.24	0.47
CDRH38D16RNP-680MC	68±20%	1007±20%	0.26	0.22	0.42
CDRH38D16RNP-101MC	100±20%	1521±20%	0.20	0.17	0.33

Power Inductor CDRH**D**R Series



◆ CDRH38D16R/HP

Sumida P/N	Inductance (μH)	D.C.R. ($\text{m}\Omega$)	Saturation Current (A) ※1		Temperature Rise Current (A) ※2
			(at 20°C)	(at 100°C)	
CDRH38D16RHPNP-R90NC	0.9 \pm 30%	20 \pm 25%	2.66	2.40	3.30
CDRH38D16RHPNP-1R6NC	1.6 \pm 30%	29 \pm 25%	2.06	1.76	2.95
CDRH38D16RHPNP-2R2NC	2.2 \pm 30%	34 \pm 25%	1.76	1.50	2.65
CDRH38D16RHPNP-3R3MC	3.3 \pm 20%	59 \pm 25%	1.46	1.22	1.95
CDRH38D16RHPNP-4R7MC	4.7 \pm 20%	82 \pm 25%	1.24	1.07	1.60
CDRH38D16RHPNP-6R8MC	6.8 \pm 20%	112 \pm 25%	1.00	0.85	1.35
CDRH38D16RHPNP-100MC	10 \pm 20%	156 \pm 20%	0.84	0.72	1.15
CDRH38D16RHPNP-150MC	15 \pm 20%	216 \pm 20%	0.66	0.56	1.00
CDRH38D16RHPNP-220MC	22 \pm 20%	371 \pm 20%	0.54	0.46	0.75
CDRH38D16RHPNP-330MC	33 \pm 20%	694 \pm 20%	0.45	0.38	0.50
CDRH38D16RHPNP-470MC	47 \pm 20%	847 \pm 20%	0.38	0.32	0.45
CDRH38D16RHPNP-680MC	68 \pm 20%	1357 \pm 20%	0.32	0.27	0.30

◆ CDRH38D16R/LD

Sumida P/N	Inductance (μH)	D.C.R. ($\text{m}\Omega$)	Saturation Current (A) ※1		Temperature Rise Current (A) ※2
			(at 20°C)	(at 100°C)	
CDRH38D16RLDNP-R90NC	0.9 \pm 30%	18 \pm 25%	1.54	1.31	3.80
CDRH38D16RLDNP-1R6NC	1.6 \pm 30%	25 \pm 25%	1.14	0.99	3.15
CDRH38D16RLDNP-2R2NC	2.2 \pm 30%	30 \pm 25%	1.01	0.88	3.00
CDRH38D16RLDNP-3R3MC	3.3 \pm 20%	37 \pm 25%	0.81	0.70	2.60
CDRH38D16RLDNP-4R7MC	4.7 \pm 20%	55 \pm 25%	0.69	0.59	2.00
CDRH38D16RLDNP-6R8MC	6.8 \pm 20%	75 \pm 25%	0.56	0.49	1.75
CDRH38D16RLDNP-100MC	10 \pm 20%	104 \pm 20%	0.47	0.40	1.45
CDRH38D16RLDNP-150MC	15 \pm 20%	163 \pm 20%	0.36	0.32	1.13
CDRH38D16RLDNP-220MC	22 \pm 20%	248 \pm 20%	0.32	0.28	0.90
CDRH38D16RLDNP-330MC	33 \pm 20%	351 \pm 20%	0.26	0.23	0.75
CDRH38D16RLDNP-470MC	47 \pm 20%	490 \pm 20%	0.22	0.19	0.65
CDRH38D16RLDNP-680MC	68 \pm 20%	867 \pm 20%	0.18	0.15	0.45
CDRH38D16RLDNP-101MC	100 \pm 20%	1335 \pm 20%	0.15	0.12	0.35

Power Inductor CDRH**D**R Series



◆ CDRH50D28R

Sumida P/N	Inductance (μH)	D.C.R. (m Ω) Max. (Typ.)	Saturation Current (A) ※1	Temperature Rise Current (A) ※2
CDRH50D28RNP-1R2NC	1.2 \pm 30%	13 \pm 25%	4.80	5.40
CDRH50D28RNP-1R6NC	1.6 \pm 30%	15 \pm 25%	4.20	4.70
CDRH50D28RNP-2R2NC	2.2 \pm 30%	17 \pm 25%	3.65	4.30
CDRH50D28RNP-3R0NC	3.0 \pm 20%	25 \pm 25%	3.10	3.50
CDRH50D28RNP-4R7NC	4.7 \pm 20%	40 \pm 25%	2.50	2.70
CDRH50D28RNP-6R8NC	6.8 \pm 20%	61 \pm 25%	2.10	2.20
CDRH50D28RNP-100NC	10 \pm 20%	87 \pm 25%	1.70	1.75
CDRH50D28RNP-150NC	15 \pm 20%	140 \pm 20%	1.40	1.30
CDRH50D28RNP-220NC	22 \pm 20%	175 \pm 20%	1.15	1.16
CDRH50D28RNP-330NC	33 \pm 20%	248 \pm 20%	0.94	0.98
CDRH50D28RNP-470NC	47 \pm 20%	370 \pm 20%	0.78	0.78

◆ CDRH50D43R

Sumida P/N	Inductance (μH)	D.C.R. (m Ω) Max. (Typ.)	Saturation Current (A) ※1	Temperature Rise Current (A) ※2
CDRH50D43RNP-2R2NC	2.2 \pm 30%	22 \pm 25%	3.60	3.80
CDRH50D43RNP-3R3NC	3.3 \pm 30%	25 \pm 25%	2.90	3.50
CDRH50D43RNP-4R7MC	4.7 \pm 20%	30 \pm 25%	2.44	3.20
CDRH50D43RNP-6R8MC	6.8 \pm 20%	37 \pm 25%	2.12	2.80
CDRH50D43RNP-100MC	10 \pm 20%	47 \pm 25%	1.75	2.40
CDRH50D43RNP-150MC	15 \pm 20%	72 \pm 25%	1.44	1.90
CDRH50D43RNP-220MC	22 \pm 20%	112 \pm 20%	1.16	1.44
CDRH50D43RNP-330MC	33 \pm 20%	160 \pm 20%	0.96	1.25
CDRH50D43RNP-470MC	47 \pm 20%	270 \pm 20%	0.78	0.91
CDRH50D43RNP-680MC	68 \pm 20%	430 \pm 20%	0.65	0.72
CDRH50D43RNP-101MC	100 \pm 20%	545 \pm 20%	0.54	0.65
CDRH50D43RNP-151MC	150 \pm 20%	775 \pm 20%	0.44	0.51
CDRH50D43RNP-221MC	220 \pm 20%	975 \pm 20%	0.36	0.49

Power Inductor CDRH**D**R Series



◆ CDRH60D28R

Sumida P/N	Inductance (μ H)	D.C.R. (m Ω) Max. (Typ.)	Saturation Current (A) ※1	Temperature Rise Current (A) ※2
CDRH60D28RNP-2R2NC	2.2 \pm 30%	20(16)	3.50	4.85
CDRH60D28RNP-3R0NC	3.0 \pm 30%	22.5(18)	3.00	4.45
CDRH60D28RNP-3R9MC	3.9 \pm 20%	27.5(22)	2.70	4.00
CDRH60D28RNP-4R7MC	4.7 \pm 20%	30(24)	2.40	3.75
CDRH60D28RNP-6R8MC	6.8 \pm 20%	46.3(37)	2.00	2.90
CDRH60D28RNP-100MC	10 \pm 20%	72.5(58)	1.60	2.25
CDRH60D28RNP-150MC	15 \pm 20%	111(89)	1.35	1.75
CDRH60D28RNP-220MC	22 \pm 20%	132(110)	1.10	1.55
CDRH60D28RNP-330MC	33 \pm 20%	198(165)	0.93	1.27
CDRH60D28RNP-470MC	47 \pm 20%	300(250)	0.76	1.02
CDRH60D28RNP-680MC	68 \pm 20%	456(380)	0.65	0.80
CDRH60D28RNP-100MC	100 \pm 20%	654(545)	0.54	0.65
CDRH60D28RNP-150MC	150 \pm 20%	942(785)	0.44	0.54

◆ CDRH60D43R

Sumida P/N	Inductance (μ H)	D.C.R. (m Ω) Max. (Typ.)	Saturation Current (A) ※1		Temperature Rise Current (A) ※2
			(at 20°C)	(at 105°C)	
CDRH60D43RNP-1R5NC	1.5 \pm 30%	15 \pm 25%	5.80	4.80	5.20
CDRH60D43RNP-2R2NC	2.2 \pm 30%	17 \pm 25%	4.80	4.00	4.40
CDRH60D43RNP-3R3NC	3.3 \pm 30%	22 \pm 25%	4.40	3.60	4.10
CDRH60D43RNP-4R7MC	4.7 \pm 20%	26 \pm 25%	3.50	2.80	3.80
CDRH60D43RNP-6R8MC	6.8 \pm 20%	31 \pm 25%	3.10	2.50	3.45
CDRH60D43RNP-100MC	10 \pm 20%	38 \pm 25%	2.60	2.00	2.90
CDRH60D43RNP-150MC	15 \pm 20%	78 \pm 25%	2.10	1.60	1.98
CDRH60D43RNP-220MC	22 \pm 20%	118 \pm 20%	1.80	1.30	1.55
CDRH60D43RNP-330MC	33 \pm 20%	178 \pm 20%	1.45	1.12	1.33
CDRH60D43RNP-470MC	47 \pm 20%	270 \pm 20%	1.20	0.90	1.04
CDRH60D43RNP-680MC	68 \pm 20%	325 \pm 20%	1.00	0.75	0.90
CDRH60D43RNP-101MC	100 \pm 20%	415 \pm 20%	0.85	0.66	0.82
CDRH60D43RNP-151MC	150 \pm 20%	670 \pm 20%	0.68	0.52	0.65
CDRH60D43RNP-221MC	220 \pm 20%	1030 \pm 20%	0.56	0.44	0.49
CDRH60D43RNP-331MC	330 \pm 20%	1325 \pm 20%	0.47	0.38	0.45

Power Inductor CDRH**D**R Series



◆ CDRH98D18R

Sumida P/N	Inductance (μH)	D.C.R. ($\text{m}\Omega$) Max. (Typ.)	Saturation Current (A) ※1	Temperature Rise Current (A) ※2
CDRH98D18RNP-4R3MC	4.3 \pm 20%	38.5(31)	3.30	3.70
CDRH98D18RNP-6R8MC	6.8 \pm 20%	66(53)	2.75	2.75
CDRH98D18RNP-100MC	10 \pm 20%	81(65)	2.30	2.40
CDRH98D18RNP-150MC	15 \pm 20%	125(100)	1.85	1.85
CDRH98D18RNP-220MC	22 \pm 20%	195(156)	1.50	1.50
CDRH98D18RNP-330MC	33 \pm 20%	287(230)	1.25	1.25
CDRH98D18RNP-470MC	47 \pm 20%	410(328)	1.05	1.05

※1、 Saturation Current: This indicates the value of D.C. current when the inductance decreases to 70% of its nominal value.

※2、 Temperature Rise Current: The actual current when temperature of coil becomes $\Delta T=40^{\circ}\text{C}$. ($T_a=20^{\circ}\text{C}$)

For More Information

Hong Kong

Tel.+852-2880-6688
FAX.+852-2565-9600

Shanghai

Tel.+86-021-58363299
FAX.+86-021-58363266

Shenzhen

Tel.+86-755-82910228
FAX.+86-755-82910338

Taipei

Tel.+886-2-27065228
FAX.+886-2-27065229

Tokyo

Tel.+81-3-5202-7112
FAX.+81-3-5202-7105

Seoul

Tel.+82-2-6237-0777
FAX.+82-2-6237-0778

Singapore

Tel.+65-6296-3388
FAX.+65-6296-3390

Malaysia

Tel.+60-3-8733-0900
FAX.+60-3-8737-7384

Chicago

Tel.+1-847-545-6700
FAX. +1-847-545-6720

California

Tel.+1-408-321-9660
FAX. +1-408-321-9308