

SPECIFICATION FOR APPROVAL

PROD. NAME	SHIELDED SMD POWER INDUCTOR	ABC'S DWG NO.	SU1040□□□□F□-□□□
		ABC'S ITEM NO.	

I . CONFIGURATION & DIMENSIONS :

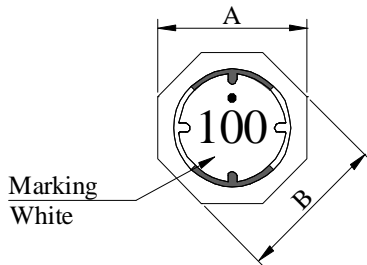

- A : 10.00 ±0.30 m/m
- B : 10.00 ±0.30 m/m
- C : 3.80 ±0.30 m/m
- D : 3.00 typ. m/m
- E : 4.00 typ. m/m
- F : 8.20 typ. m/m
- G : 4.20 ref. m/m
- H : 8.20 ref. m/m
- I : 1.40 ref. m/m

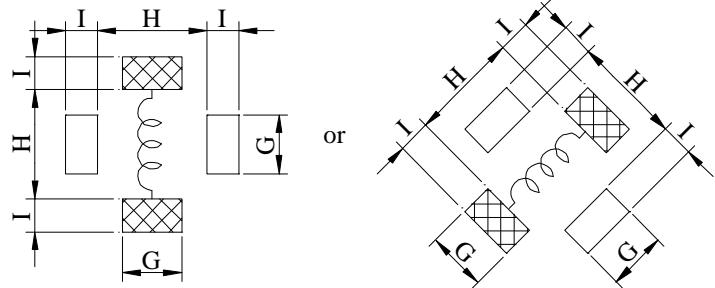
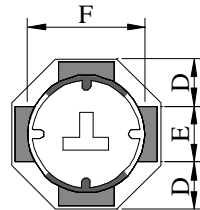
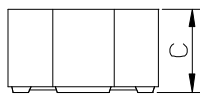

(PCB Pattern)

II . SCHEMATIC DIAGRAM :

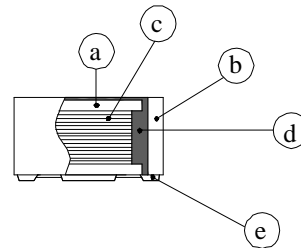
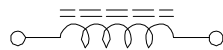

III . MATERIALS :

- a . Core : Ferrite DR core
- b . Core : Ferrite RI core
- c . Wire : Enamelled copper wire (Class F & H)
- d . Adhesive : Epoxy resin
- e . Terminal : Ag/Ni/Sn
- f . Remark : Products comply with RoHS' requirements

Peak Temp : 260°C max.
 Max time above 230°C : 50sec max.
 Max time above 200°C : 70sec max.

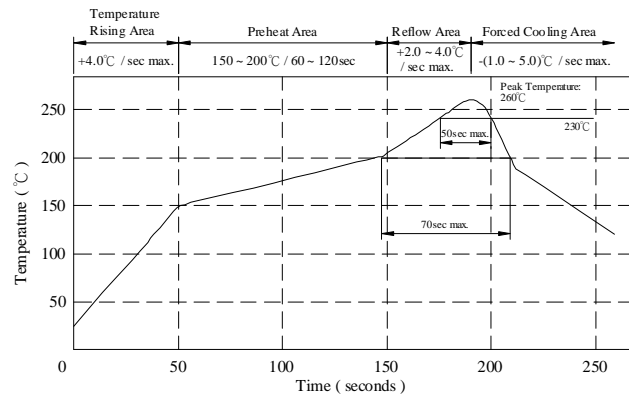

IV . GENERAL SPECIFICATION :

- a . Temp. rise : 40°C typ.
- b . Rated current :
Base on temp. rise & ΔL / LOA=35% typ.
- c . Storage temp. : -40°C ----+125°C
- d . Operating temp. : -40°C ----+105°C
- e . Resistance to solder heat : 260°C.10 secs.

SPECIFICATION FOR APPROVAL

PROD. NAME	SHIELDED SMD POWER INDUCTOR	ABC'S DWG NO.	SU1040□□□□F□-□□□
		ABC'S ITEM NO.	

V . ELECTRICAL CHARACTERISTICS :

DWG No.	Inductance (μ H)	Q ref.	SRF (MHz) typ.	RDC (m Ω)		I _{rms} (A) typ.	I _{sat} (A) typ.
				typ.	max.		
SU10403R8YF□-□□□	3.8 ±30%	14	40.0	13.5	18.0	6.60	5.80
SU10405R0YF□-□□□	5.0 ±30%	12	28.0	17.5	23.0	5.20	4.70
SU10406R2YF□-□□□	6.2 ±30%	12	24.0	21.5	28.0	4.70	4.30
SU1040100YF□-□□□	10.0 ±30%	16	22.0	32.0	42.0	4.40	3.80
SU1040150YF□-□□□	15.0 ±30%	18	16.0	60.0	78.0	2.90	2.80
SU1040220YF□-□□□	22.0 ±30%	16	12.0	75.0	98.0	2.55	2.48
SU1040330YF□-□□□	33.0 ±30%	16	10.0	110.0	140.0	2.05	2.00
SU1040470YF□-□□□	47.0 ±30%	16	8.0	170.0	220.0	1.62	1.56
SU1040680YF□-□□□	68.0 ±30%	16	7.0	245.0	320.0	1.45	1.40
SU1040101YF□-□□□	100.0 ±30%	14	6.0	320.0	415.0	1.18	1.14
SU1040221YF□-□□□	220.0 ±30%	14	4.0	760.0	950.0	0.78	0.72
SU1040331YF□-□□□	330.0 ±30%	14	2.5	1080.0	1350.0	0.62	0.60

- 1) . □ : Packaging Information... A □ : Bulk B □ : Taping Reel
- 2) . "- □□□ : Reference code
- 3) . Inductance Test Freq. : 100KHz / 0.1V
- 4) . Q Test Freq. : 3R8~6R2--7.96MHz , 100~680--2.52MHz , 101~331--0.796MHz
- 5) . I_{sat} base on $\Delta L / L0A=35\%$ typ.
- 6) . I_{rms} base on Temp. rise 40°C typ.

@ Inductance VS. DC Superposition Characteristics

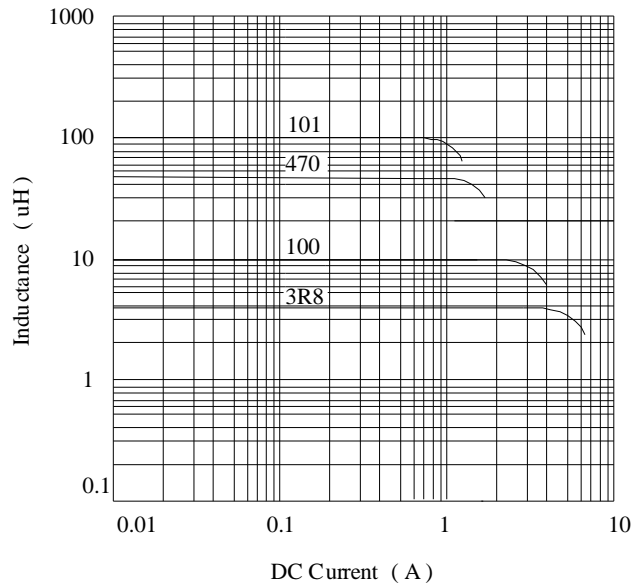

SPECIFICATION FOR APPROVAL

REF :20080805-A

PAGE: 3

PROD. NAME	SHIELDED SMD POWER INDUCTOR	ABC'S DWG NO.	SU1040□□□□F□-□□□
		ABC'S ITEM NO.	

VI . PACKAGING INFORMATION :

(1) Configuration

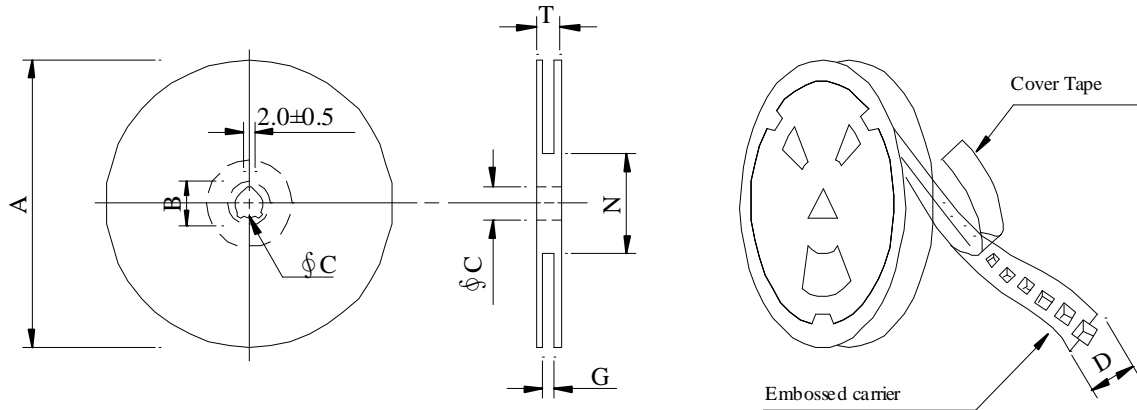

※Carrier tape width : D

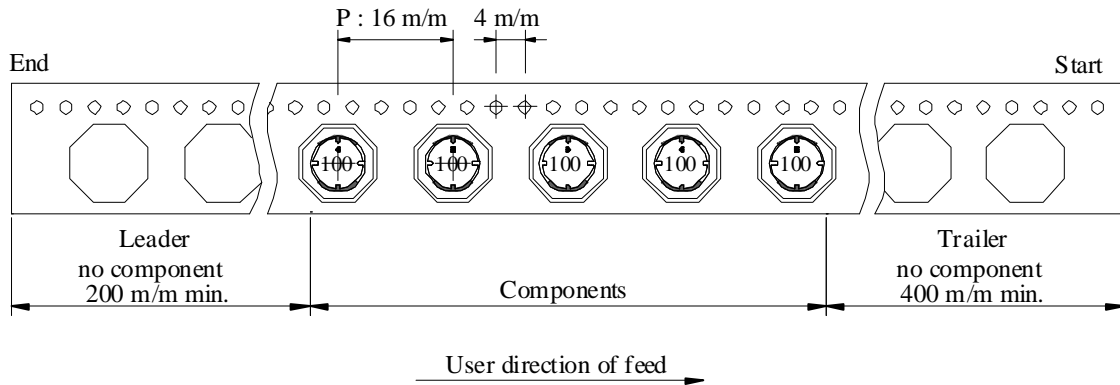

(2) Dimensions

Unit:m/m

Style	A	B	C	D	G	N	T
13 - 24	330	21±0.8	13±0.5	24	26 ⁺⁰	50 ⁻⁰	30.4

(3) QTY & G.W. Per package

Series	Inner : Reel			Outer : Carton		
	QTY (pcs)	G.W. (gw)	Style	QTY (pcs)	G.W. (Kg)	Size (cm)
SU1040	800	1,300	13 - 24	3,200	7.5	40 x 40 x 24

AR-001A

SPECIFICATION FOR APPROVAL

REF :20080805-A

PAGE: 4

PROD. NAME	SHIELDED SMD POWER INDUCTOR	ABC'S DWG NO.	SU1040□□□□F□-□□□
		ABC'S ITEM NO.	

VII . DWGING NUMBER EXPRESSION :

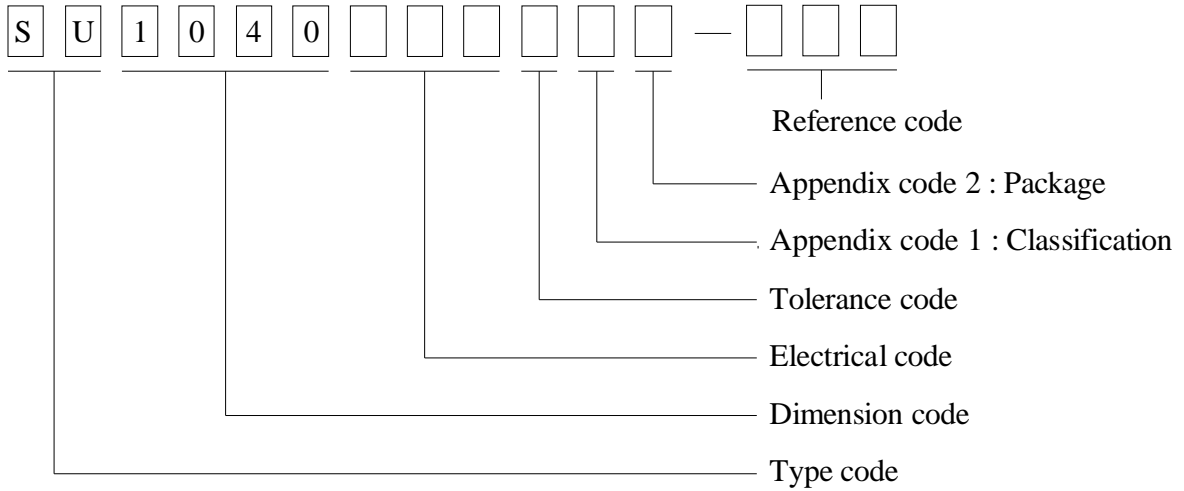

Appendix code 1 : Product Classification

- F : Lead Free Standard products comply with RoHS' requirements
- 1 ~ 9 : Lead Free Special products comply with RoHS' requirements

Appendix code 2 : Package Information

Code	Inner package	Inner package QTY	Remark
A	T.B.D.	T.B.D.	
B	T / R (Reel package)	800 pcs	

SPECIFICATION FOR APPROVAL

REF :20080805-A

PAGE: 5

PROD. NAME	SHIELDED SMD POWER INDUCTOR	ABC'S DWG NO. ABC'S ITEM NO.	SU1040□□□□F□-□□□
---------------	--------------------------------	---------------------------------	------------------

VIII . RELIABILITY TEST :

Test item	Specification	Test condition						
Solderability	More than 95% of the terminal electrode shall be covered With fresh solder.	Preheat : 155°C / 4 hours. Solder : Sn96.5 / Ag3 / Cu0.5 or equivalent Solder temp. : 235±5°C Flux : Rosin Dip time : 5±0.5 seconds						
Thermal shock test (Temp. cycle)	Electrical oharacteristics shall not change more than ±20%	<table style="width: 100%; border: none;"> <tr> <td style="text-align: center;">Room temp. 15 minutes</td> <td style="text-align: center;">→</td> <td style="text-align: center;">-40 °C 30 minutes</td> </tr> <tr> <td style="text-align: center;">Room temp. 15 minutes</td> <td style="text-align: center;">→</td> <td style="text-align: center;">+105 °C 30 minutes</td> </tr> </table> <p>Total : 50 cycles</p>	Room temp. 15 minutes	→	-40 °C 30 minutes	Room temp. 15 minutes	→	+105 °C 30 minutes
Room temp. 15 minutes		→	-40 °C 30 minutes					
Room temp. 15 minutes		→	+105 °C 30 minutes					
Humidity test		Temperature : 40±2°C Humidity : 90±5% Time : 1000 hours						
High temp. Resistance test	Temperature : 105±5°C Applied current : Per spec. Time : 96 hours							

AR-001A



SPECIFICATION FOR APPROVAL

REF :20080805-A

PAGE: 6

PROD. NAME	SHIELDED SMD POWER INDUCTOR	ABC'S DWG NO.	SU1040□□□□F□-□□□
		ABC'S ITEM NO.	

IX . UL CARD :

OBMW2 September 8, 2000
Magnet Wire-Component
JUNG SHING WIRE CO LTD E174837
231 CHUNG CHENG RD, SEC 3 JEN-TEH HSIANG, TAINAN
HSIEN TAIWAN

Mtl Dsg	Mark Dsg	BC	Coat Typ	OC	ANSI Type	Temp Class
AIW	---	Polyamideimide		---	MW81-C	220
CFUEWB	---	Polyurethane		---	MW75C	130
EIAIW	---	Polyesterimide		Polyamideimide	MW35C	200
EILOCKY	---	Polyesterimide		Polyamide	---	180
EILOCKW	---	Polyesterimide		Modified Epoxy	---	200
EIW	---	Polyesterimide		---	---	220
EIW-2	---	Polyesterimide		---	MW74-C	200
FL.EILOCKY	---	Modified Polyester		Polyamide	---	155
LSFFW	---	Polyurethane		---	MW79-C	155
LSUEW	---	Polyurethane		---	---	130
PEW	---	Polyester		---	---	155
PEY	---	Polyester		Nylon	MW24-C	155
SF.FLW	---	Modified Polyester		---	MW26C	155
SF.EIW	---	Polyesterimide		---	MW77C	180
SF.BY@	---	Modified Polyester		Nylon	MW27-C	155
SF.FLY@	---	Modified Polyester		Nylon	MW27-C	155
SF.BLOCKBS	---	Modified Polyester		Modified Polyamide	---	155
SF.EILOCKY#	---	Polyesterimide		Polyamide	---	180
SF.EILOCKBS	---	Polyesterimide		Modified Polyamide	---	180
SF.BW@	---	Modified Polyester		---	MW26C	155
SFFW	---	Polyurethane		---	MW79	155

A not-for-profit organization dedicated to public safety and committed to quality service

287806002 Page 1 of 2

Mtl Dsg	Mark Dsg	BC	Coat Typ	OC	ANSI Type	Temp Class
SFFY	---	Polyurethane		Polyamide	MW80C	155
UEW-1	---	Polyurethane		---	MW2-C	105
UEW-2	---	Polyurethane		---	---	130
UEW-4	---	Polyurethane		---	MW75C	130
UEY	---	Polyurethane		Nylon	MW28-C	130
UEY-2	---	Polyurethane		Polyamide	MW28-C	130

@- May be suffixed by LZ; # - May be suffixed by LZ, EL or LZI.
LZ - Signifies magened wires twisted together; EL - signifies base coated magnet wire laid parallel with top coat applied overall; LZL - signifies base coated magnet wire twisted together and covered with top coat overall.
Marking: Company name or trademarks **JSW** or 聚晶, material designation or marked designation on packaed or reel, and Recognized Component Mark.

See General Information Preceding These Recognitions
For use only in equipment where the acceptability of the combination is determined by Underwriters Laboratories Inc.

287806002 Page 2 of 2 OBMW2/E174837
September 8, 2000

AR-001A



SPECIFICATION FOR APPROVAL

REF :20080805-A

PAGE: 7

PROD. NAME	SHIELDED SMD POWER INDUCTOR	ABC'S DWG NO.	SU1040□□□□F□-□□□
		ABC'S ITEM NO.	

OBMW2 August 27, 1999
Magnet Wire-Component

ELEKTRISOLA (MALAYSLA) SDN BHD E143312
IALAN DAMN SATU IANDA BAIK 28750 BENTONG, PAHANG
DARUL MAKMUR MALAYSIA

Mtl Dsg	Mark Dsg	Coating Type		ANSI Typ	Temp Class
		BC	OC		
Estersol 160	E180	Polyesterimide (solderable)	—	MW-77	180
Amldester 200	A200	Polyesterimide	—	MW-74	200
Polysol-N 155	PN155	Polyurechane	Nylon	MW-80,	155,
				MW-28	100
Polysol 155	P155	Polyurechane	—	MW-79,	155,
				MW-79	130
Polysol 155g	Pg155	Polyurechane	—	MW-79	130
Polysol 155p	Pp155,Gp155	Polyurechane	—	MW-79	155
Polysol 160	P160	Polyurechane	—	MW-79	155
Polysol 180	P180	Polyurechane	—	MW-79	155
Polysol 170	P170 or G170	Polyurechane	—	MW-79	156
Polysol-N 180	PN180	Polyurechane	Nylon	—	180

Marking : Company name/material designation or marked designation and factory identification on package ok reel

See General Information preceding These Recognitions

For use only in equipment where the acceptability of the combination is determined by Underwriters Laboratories Inc.

AR-001A

