

Multi Control Devices TACT Switch™ Low-profile 4-direction with Center-push Function (Surface Mount Type)

SKRV Series



Compact, low-profile type with height of 1.55mm.

Multi Control
Devices

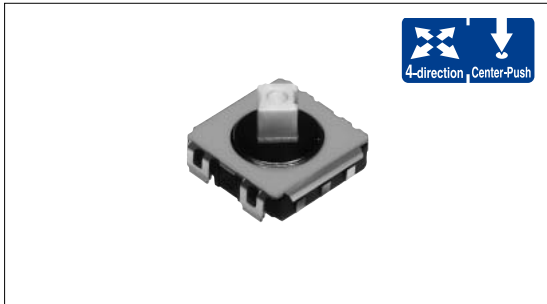

Product Line

Product No.	Operating force		Travel (mm)		Rating (max.)	Rating (min.)	Operating life (5mA 5V DC)	Initial contact resistance	Variety	Minimum order unit (pcs.)
	4-direction	Center-push	4-direction	Center-push						
SKRVAE010	1.2N	2.4N	0.25m	0.15m	50mA	10μA	for each direction 200,000cycles	500m max.	Without guide bosses	1,500
SKRVABE010									With guide bosses	

Specification of Embossed Taping Package (Taping Packaging for Auto-insertion)

Reel Size Unit:mm

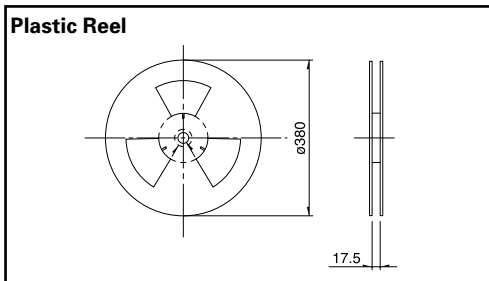

Number of packages (pcs.)			Tape width (mm)
1 reel	1 case /Japan	1 case /export packing	
1,500	12,000	12,000	16

Variable Resistor Type
Switch Type

Dimension

Unit:mm

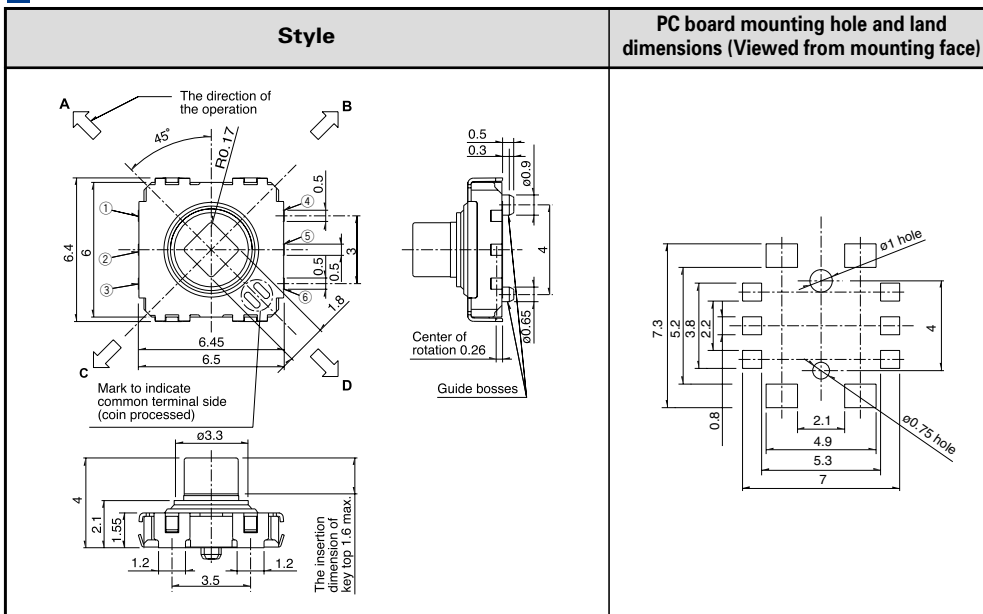

Circuit Diagram

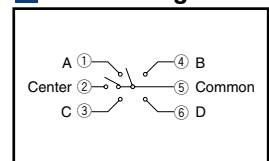













Notes

1. Please always solder the frame to secure switch intensity.
2. Please place purchase orders for taping products per minimum order unit (1 reel or 1 case).

Refer to P.492 for soldering conditions.

List of Varieties

Multi Control Devices

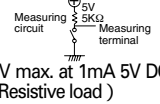
Series		Switch type						
		RKJXT1F	RKJXM	RKJXL	RKJXS	SKRV	SKRH	
Items		SKRHAA, SKRHAB		SKRHAC, SKRHAD				
Photo								
Function								
Dimensions (typical value) (mm)	W	17	20.5	13	11.7	6.45	7.35/7.45	
	D				12.3	6.4	7.5	
	H	10.5	5.45	6.4	2.3	4	5	
Outlined specifications	Number of operating shafts	Single-shaft	Single-shaft/Dual-shaft	Single-shaft				
	Shaft material	Metal			Resin			
	Directional resolution	4-direction	8-direction			4-direction		
	Directional operating feeling (tactile feeling)	With		Without	With			
	Lever return mechanism	With						
	Center-push switch	With						
	Encoder	With	Without/With	Without				
Operating temperature range		-40 to +85	-30 to +80	-30 to +70	-20 to +70		-30 to +85	
Rating (max. χ Resistive load)		10mA 5V DC			50mA 12V DC			
Electrical performance	Output voltage	_____			 1V max. at 1mA 5V DC (Resistive load)		_____	
	Directional resolution	4-direction	8-direction			4-direction		
	Insulation resistance	100M min. 250V DC			50M min. 50V DC	100M min. 100V DC		
	Voltage proof	300V AC for 1min. or 360V AC for 2s			50V AC for 1min.	100V AC for 1min.		
	Directional operating force	40 ± 25mN·m	Direction A, B, C, D 30 ± 20mN·m Direction AB, BC, CD, DA 25 ± 20mN·m	10 ± 7mN·m	0.8 ± 0.5N	1.2 ± 0.6N	1.23 ± 0.69N 1.2 ± 0.69N	
Mechanical performance	Push operating force	5 ± 2N	3 ± 1.5N	4.5 ± 1N	2.5 ± 1.5N	2.4 ± 0.69N	2.35 ± 0.69N	
	Encoder detent torque	15 ± 8mN·m	12 ± 8mN·m	_____				
	Terminal strength	5N for 1min.						
	Actuator strength	Pushing direction	100N			30N	_____	
		Operating direction	0.4N·m	0.3N·m	0.15N·m	20N	_____	
Endurance	Vibration	8.3 ± 1 to 200 ± 4 to 8.3 ± 1Hz, 4.4G fixed (for 15 min./1 cycle) 3 angles each 2 hours				10 to 55 to 10Hz/min., the amplitude is 1.5mm for all the frequencies, in the 3 direction of X, Y and Z for 2 hours respectively		
	Operating life without load	_____						
	Operating life with load (at rated load)	_____						
Environmental performance	Cold	-40 ± 2 for 500h			-40 ± 2 for 96h	-30 ± 2 for 96h		
	Dry heat	85 ± 2 for 500h			85 ± 2 for 96h	80 ± 2 for 96h		
	Damp heat	60 ± 2, 90 to 95%RH for 500h			60 ± 2, 90 to 95%RH for 96h			
Soldering	Manual soldering	350 ± 5 3s max.			350 ± 10 3 ^s	350 max. 3s max.		
	Dip soldering	260 ± 5, 5 ± 1s		260 max. 6s max.	_____			
	Reflow soldering	Please see P.492						
Page		475	476	478	479	480	481	

Variable Resistor Type

Switch Type

Switch Type Multi Control Devices Soldering Conditions492
 Switch Type Multi Control Devices Cautions493

Soldering Conditions

Example of Reflow Soldering Condition

1. Heating method: Double heating method with infrared heater.
2. Temperature measurement: Thermocouple 0.1 to 0.2 CA(K) or CC(T) at solder joints copper foil surface) A heat resistive tape should be used to fix thermocouple.
3. Temperature profile

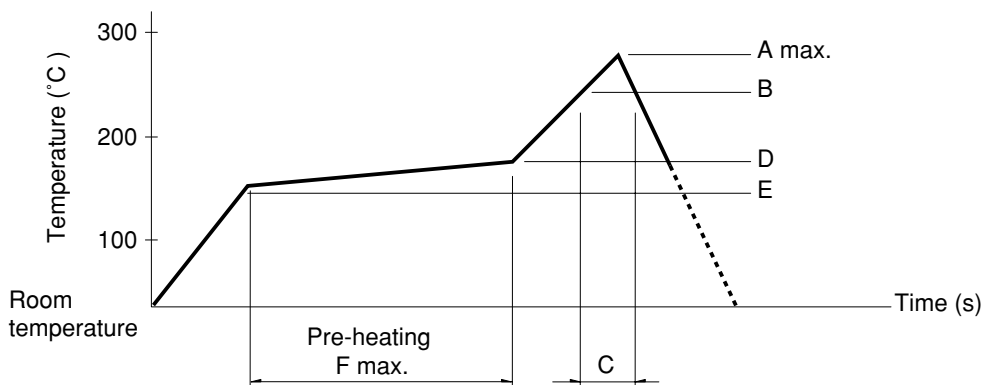

Series(Reflow type)	A() 3s max.	B()	C(s)	D()	E()	F(s)
RKJXS	260	230	40	150	150	120
SLLB, SLLB5	240		20			
SKRV/SKRH/SKQUBA,DB/SSAF/SRBE	260		40	180		

Notes

1. The above temperature shall be measured on the mounting surface of a PC board. There are cases where the PC board's temperature greatly differs from that of the switch, depending on the material, size thickness of PC boards and others. The above-stated conditions shall also apply to switch surface temperatures.
2. Soldering conditions differ depending on reflow soldering machines. Prior verification of soldering condition is highly recommended.