

DESCRIPTION

The PT8914 is a cost-efficient single chip for USB speaker application. It integrated USB controller, 16 bit audio DAC and high power, high efficient Class-D audio amplifier in one chip. Only few external components needed in application circuits makes it suite for the USB powered speaker system.

The I/O interface is totally follow the USB audio class specification, no special driver software needs to install on user's computer and support most popular Operating System in the recent market. The PT8914 is a truly plug and play USB audio device. The embedded GPIO pins provide the mute and volume adjustment functions.

FEATURES

- Compliant with USB2.0 full speed specification.
- Compliant with USB Audio class specification.
- Compliant with USB HID class specification for volume, mute remote control.
- Supply voltage: 4.5~5.5V
- Built-in class-D audio amplifier with 1Watt output power for each channel.
(USB 500mA+8ohm speaker)
- Built-in PLL (48MHz for USB)
- Key pad control for mute, volume up and volume down.
- Packages: 24 pins SOP

APPLICATION

- USB Speaker

BLOCK DIAGRAM

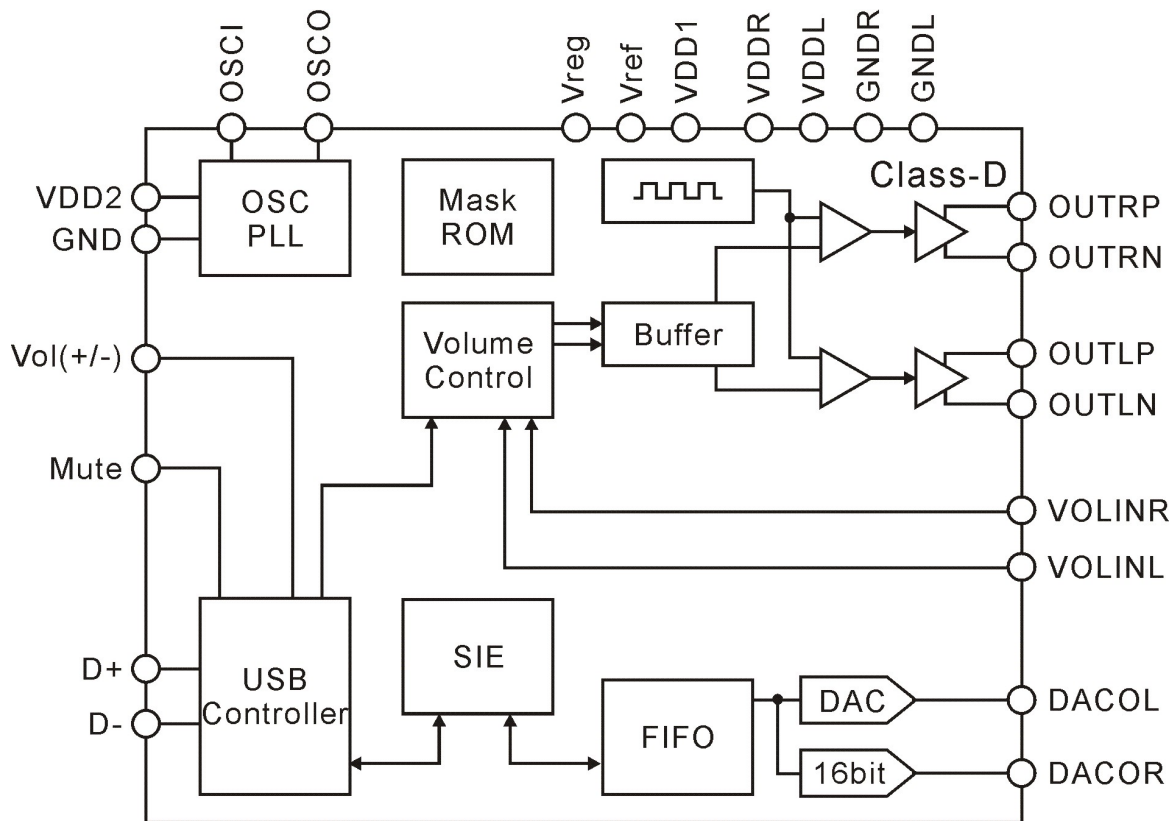

APPLICATION CIRCUIT

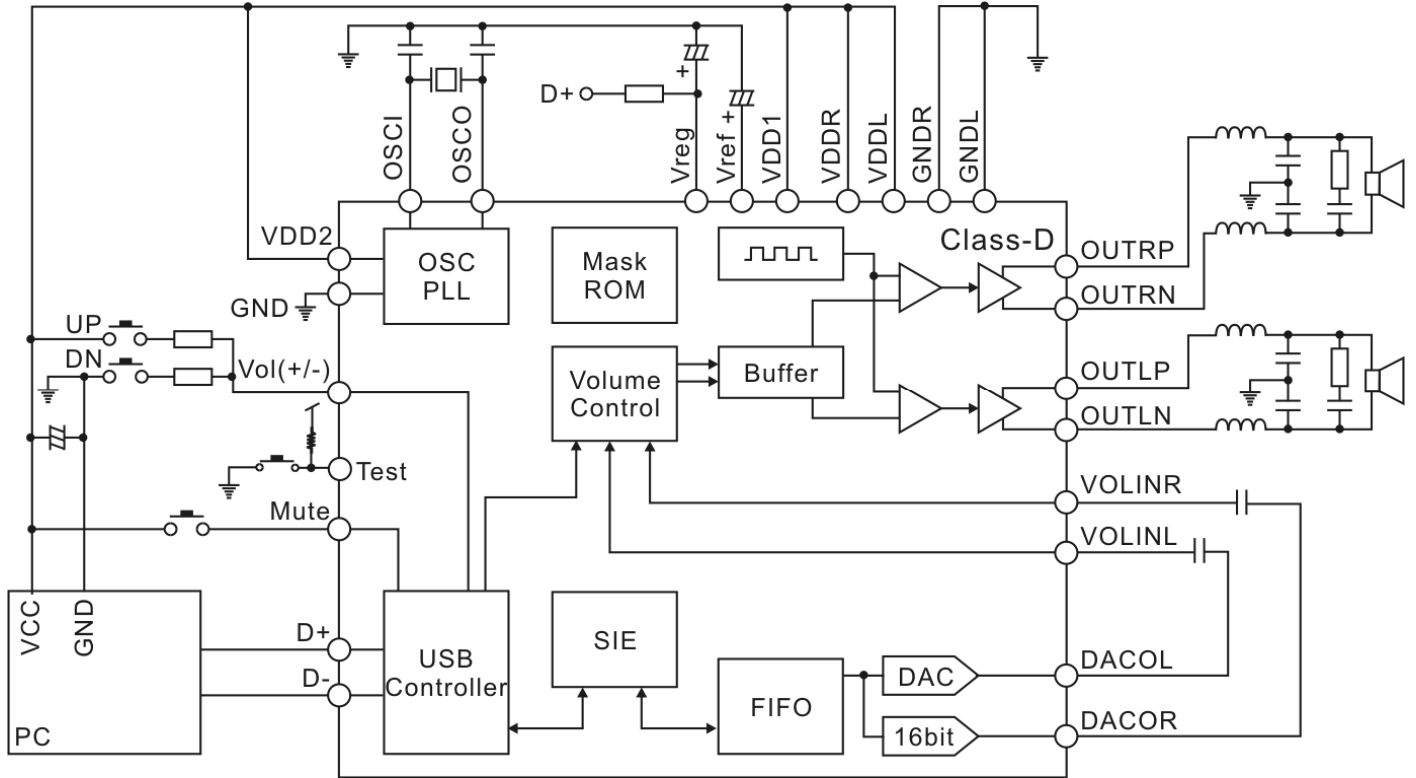

ORDER INFORMATION

Valid Part Number	Package Type	Top Code
PT8914-S	24 Pins, SOP, 300mil	PT8914-S

PIN CONFIGURATION

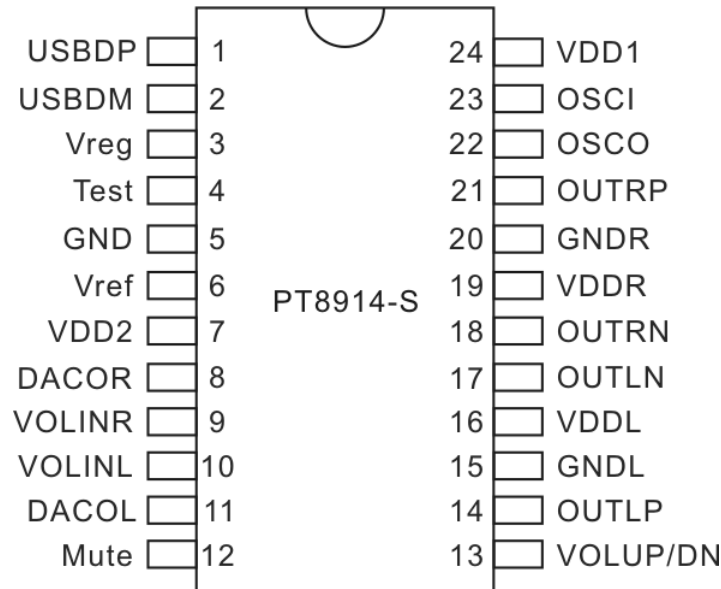

PIN DESCRIPTION

Pin Name	I/O	Description	Pin No.
USBDP	I	USB data plus	1
USBDM	I	USB data minus	2
Vreg	Power	Regulator 3.3V power	3
Test	I	Tie to high, tie to low to issue remote wake up signal	4
GND	power	DAC ground	5
Vref	Power	Reference voltage	6
VDD2	Power	DAC power	7
DACOR	O	DAC output right channel	8
VOLINR	I	Volume in right channel	9
VOLINL	I	Volume in left channel	10
DACOL	O	DAC output left channel	11
MUTE	I	GPIO, Mute	12
VOLUP/DN	I	GPIO, Volume up/down	13
OUTLP	O	Left channel positive output	14
GNDL	Power	Left channel ground	15
VDDL	Power	Left channel power	16
OUTLN	O	Left channel negative output	17
OUTRN	O	Right channel negative output	18
VDDR	Power	Right channel power	19
GNDR	Power	Right channel ground	20
OUTRP	O	Right channel positive output	21
OSCO	O	Output for 12MHz oscillator	22
OSCI	I	Input for 12MHz oscillator	23
VDD1	Power	USB 5V power	24

IMPORTANT NOTICE

Princeton Technology Corporation (PTC) reserves the right to make corrections, modifications, enhancements, improvements, and other changes to its products and to discontinue any product without notice at any time.

PTC cannot assume responsibility for use of any circuitry other than circuitry entirely embodied in a PTC product. No circuit patent licenses are implied.

Princeton Technology Corp.
2F, 233-1, Baociao Road,
Sindian, Taipei 23145, Taiwan
Tel: 886-2-66296288
Fax: 886-2-29174598
<http://www.princeton.com.tw>