

Features

- Single 3-V Supply Voltage
- High Power-added Efficient Power Amplifier (P_{out} Typically 23 dBm)
- Ramp-controlled Output Power
- Low-noise Preamplifier (NF Typically 2.1 dB)
- Biasing for External PIN Diode T/R Switch
- Current-saving Standby Mode
- Few External Components
- QFN20 Package with Extended Performance

1. Description

The T7024 is a monolithic SiGe transmit/receive front-end IC with power amplifier, low-noise amplifier and T/R switch driver. It is especially designed for operation in TDMA systems like Bluetooth® and WDCT.

Due to the ramp-control feature and a very low quiescent current, an external switch transistor for V_S is not required.

Figure 1-1. Block Diagram

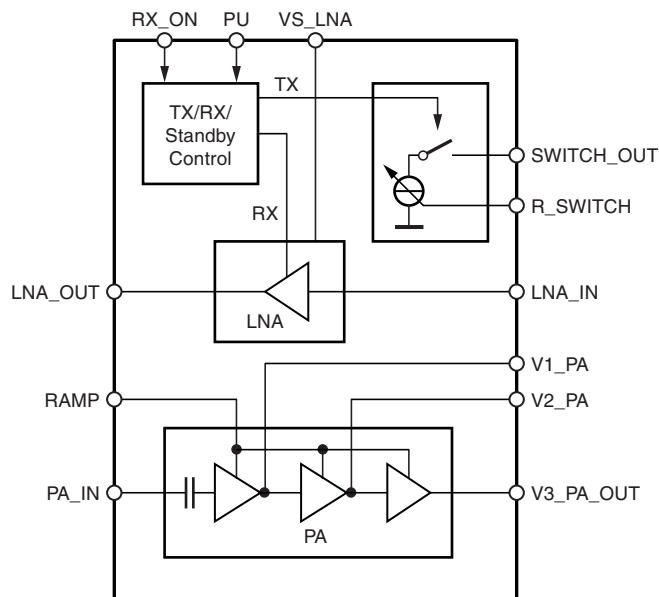

Bluetooth/ISM 2.4-GHz Front-end IC

T7024

2. Pin Configuration

Figure 2-1. Pinning QFN20

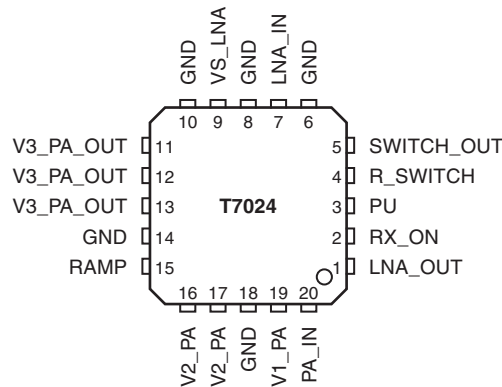

Table 2-1. Pin Description

Pin	Symbol	Function
1	LNA_OUT	Low-noise amplifier output
2	RX_ON	RX active high
3	PU	Power-up active high
4	R_SWITCH	Resistor to GND sets the PIN diode current
5	SWITCH_OUT	Switched current output for PIN diode
6	GND	Ground
7	LNA_IN	Low-noise amplifier input
8	GND	Ground
9	VS_LNA	Supply voltage input for low-noise amplifier
10	GND	Ground
11	V3_PA_OUT	Inductor to power supply and matching network for power amplifier output
12	V3_PA_OUT	Inductor to power supply and matching network for power amplifier output
13	V3_PA_OUT	Inductor to power supply and matching network for power amplifier output
14	GND	Ground
15	RAMP	Power ramping control input
16	V2_PA	Inductor to power supply for power amplifier
17	V2_PA	Inductor to power supply for power amplifier
18	GND	Ground
19	V1_PA	Supply voltage for power amplifier
20	PA_IN	Power amplifier input
Slug	GND	Ground

3. Absolute Maximum Ratings

Stresses beyond those listed under “Absolute Maximum Ratings” may cause permanent damage to the device. This is a stress rating only and functional operation of the device at these or any other conditions beyond those indicated in the operational sections of this specification is not implied. Exposure to absolute maximum rating conditions for extended periods may affect device reliability.

Parameters	Symbol	Value	Unit
Supply voltage Pins VS_LNA, V1_PA, V2_PA, V3_PA_OUT	V_S	6	V
Junction temperature	T_j	150	°C
Storage temperature	T_{stg}	-40 to +125	°C
RF input power LNA	P_{inLNA}	5	dBm
RF input power PA	P_{inPA}	10	dBm

Electrostatic sensitive device.

Observe precautions for handling.



4. Thermal Resistance

Parameters	Symbol	Value	Unit
Junction ambient QFN20, slug soldered on PCB	R_{thJA}	27	K/W

5. Handling

Do not operate this part near strong electrostatic fields. This IC meets class 1 ESD test requirement (HBM in accordance to EIA/JESD22-A114-A (October 97) and class A ESD test requirement (MM) in accordance to EIA/JESD22-A115A.

6. Operating Range

All voltages are referred to ground (pins GND and slug). Power supply points are VS_LNA, V1_PA, V2_PA, V3_PA_OUT. The table represents the sum of all supply currents depending on the TX/RX mode.

Parameters	Symbol	Min.	Typ.	Max.	Unit
Supply voltage Pins V1_PA, V2_PA and V3_PA_OUT	V_S	2.7	3.0	4.6	V
Supply voltage, pin VS_LNA	V_S	2.7	3.0	5.5	V
Supply current TX	I_S		165		mA
Supply current RX	I_S		8		mA
Standby current, PU = 0	$I_{S_standby}$		10		μA
Ambient temperature	T_{amb}	-25	+25	+85	°C

7. Electrical Characteristics

Test conditions (unless otherwise specified): $V_S = 3.0V$, $T_{amb} = 25^\circ C$

Parameters	Test Conditions	Symbol	Min.	Typ.	Max.	Unit
Power Amplifier⁽¹⁾						
Supply voltage	Pins V1_PA, V2_PA, V3_PA_OUT	V_S	2.7	3.0	4.6	V
Supply current	TX	I_{S_TX}		165		mA
	RX (PA off), $V_{RAMP} \leq 0.1V$	I_{S_RX}			10	μA
Standby current	Standby	$I_{S_standby}$			10	μA
Frequency range	TX	f	2.4		2.5	GHz
Gain-control range	TX	ΔGp	60	42		dB
Power gain maximum	TX, pin PA_IN to V3_PA_OUT	Gp	28	30	33	dB
Power gain minimum	TX, pin PA_IN to V3_PA_OUT	Gp	-40		-17	dB
Ramping voltage maximum	TX, power gain (maximum) Pin RAMP	$V_{RAMP\ max}$	1.7	1.75	1.83	V
Ramping voltage minimum	TX, power gain (minimum) Pin RAMP	$V_{RAMP\ min}$		0.1		V
Ramping current maximum	TX, $V_{RAMP} = 1.75V$, pin RAMP	$I_{RAMP\ max}$			0.5	mA
Power-added efficiency	TX	PAE	35	40		%
Saturated output power	TX, input power = 0 dBm referred to pins V3_PA_OUT	P_{sat}	22	23	24	dBm
Input matching ⁽²⁾	TX, pin PA_IN	Load VSWR		< 1.5:1		
Output matching ⁽²⁾	TX, pins V3_PA_OUT	Load VSWR		< 1.5:1		
Harmonics at $P_{sat} = 23\ dBm$	TX, pins V3_PA_OUT	2 fo			-30	dBc
	TX, pins V3_PA_OUT	3 fo			-30	dBc
T/R Switch Driver (Current Programming by External Resistor from R_SWITCH to GND)						
Switch-out current output	Standby, pin SWITCH_OUT	$I_{S_O_standby}$			1	μA
	RX	$I_{S_O_RX}$			1	μA
	TX at 100 Ω	$I_{S_O_100}$		1.7		mA
	TX at 1.2 k Ω	$I_{S_O_1k2}$		7		mA
	TX at 33 k Ω	$I_{S_O_33k}$		17		mA
	TX at ∞	$I_{S_O_R}$		19		mA
Low-noise Amplifier⁽³⁾						
Supply voltage	All, pin VS_LNA	V_S	2.7	3.0	5.5	V
Supply current	RX	I_S		8	9	mA
Supply current (LNA and control logic)	TX (control logic active) Pin VS_LNA	I_S			0.5	mA

- Notes:
1. Power amplifier shall be unconditionally stable, maximum duty cycle 100%, true CW operation, maximum load mismatch and duration: load VSWR = 10:1 (all phases) 10s, $Z_G = 50\Omega$
 2. With external matching network, load impedance 50 Ω
 3. Low-noise amplifier shall be unconditionally stable.
 4. With external matching components.
 5. LNA gain can be adjusted with RX_ON voltage according to [Figure 9-10 on page 9](#). Please note, that for RX_ON below 1.4V the T/R switch driver switches to TX mode.

7. Electrical Characteristics (Continued)

Test conditions (unless otherwise specified): $V_S = 3.0V$, $T_{amb} = 25^\circ C$

Parameters	Test Conditions	Symbol	Min.	Typ.	Max.	Unit
Standby current	Standby, pin VS_LNA	$I_{S_standby}$		1	10	μA
Frequency range	RX	f	2.4		2.5	GHz
Power gain ⁽⁵⁾	RX, pin LNA_IN to LNA_OUT	Gp	15	16	19	dB
Noise figure	RX	NF		2.1	2.3	dB
Gain compression	RX, referred to pin LNA_OUT	O1dB	-9	-7	-6	dBm
3 rd -order input interception point	RX	IIP3	-16	-14	-13	dBm
Input matching ⁽⁴⁾	RX, pin LNA_IN	VSWRin			2:1	
Output matching ⁽⁴⁾	RX, pin LNA_OUT	VSWRout			2:1	
Logic Input Levels (RX_ON, PU) ⁽⁵⁾						
High input level	= '1' pins RX_ON and PU	V_{iH}	2.4		V_{S_LNA}	V
Low input level	= '0'	V_{iL}	0		0.5	V
High input current	= '1' $V_{iH} = 2.4V$	I_{iH}		40	60	μA
Low input current	= '0'	I_{iL}			0.2	μA

- Notes:
1. Power amplifier shall be unconditionally stable, maximum duty cycle 100%, true CW operation, maximum load mismatch and duration: load VSWR = 10:1 (all phases) 10s, $Z_G = 50\Omega$
 2. With external matching network, load impedance 50Ω
 3. Low-noise amplifier shall be unconditionally stable.
 4. With external matching components.
 5. LNA gain can be adjusted with RX_ON voltage according to [Figure 9-10 on page 9](#). Please note, that for RX_ON below 1.4V the T/R switch driver switches to TX mode.

8. Control Logic PA and LNA/Antenna Switch Driver

PU	RX_ON	Ramp ⁽¹⁾	PA	LNA	Antenna Switch Driver	Operation Mode
0	0	0	off	off	off	standby
0	0	1	on	off	off	(2)
0	1	0	off	on	off	(3)
0	1	1	on	on	off	(4)
1	0	0	off	off	on	(4)
1	0	1	on	off	on	TX
1	1	0	off	on	off	RX
1	1	1	on	on	off	(5)

- Notes:
1. "0" = $V_{RAMP} \leq 0.1V$, "1" = V_{RAMP} typically 1.75V, $1.3V < V_{RAMP} < 1.83V$ controls gain and output power, compare [Figure 9-5 on page 7](#)
 2. Only for special operation, e.g. only PA operation, no LNA/switch driver operation
 3. Only for special operation, e.g. no switch driver operation
 4. Only for special operation
 5. Only for special operation, e.g. separate TX/RX antennas, TX and RX operation at the same time

9. Typical Operating Characteristics

Figure 9-1. LNA: Gain and Noise Figure versus Frequency

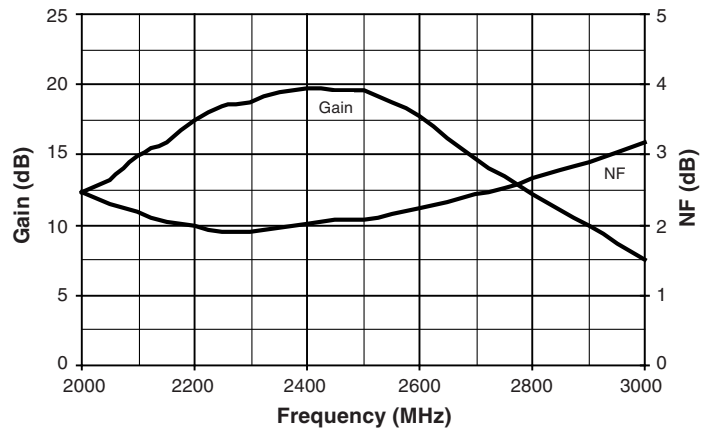

Figure 9-2. LNA: NF and Gain versus Temperature

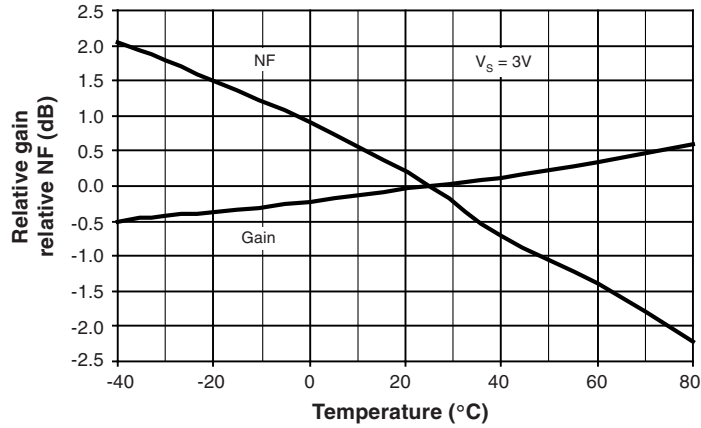

Figure 9-3. LNA: Typical Switch-out Current versus R_{switch}

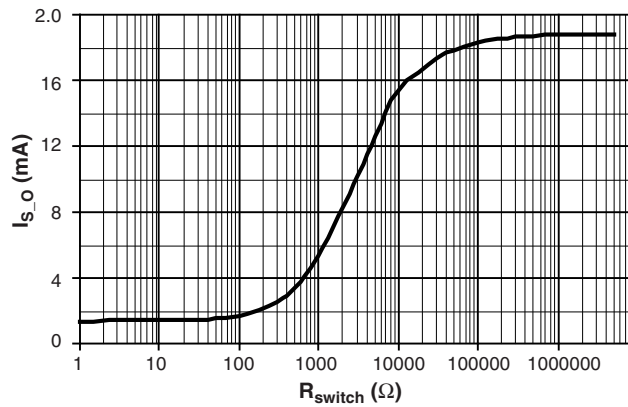

Figure 9-4. PA: Output Power and PAE versus Supply Voltage

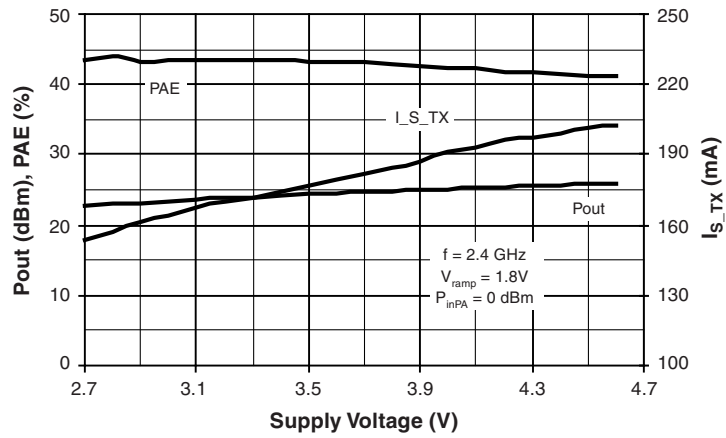

Figure 9-5. PA: Output Power and PAE versus Ramp Voltage

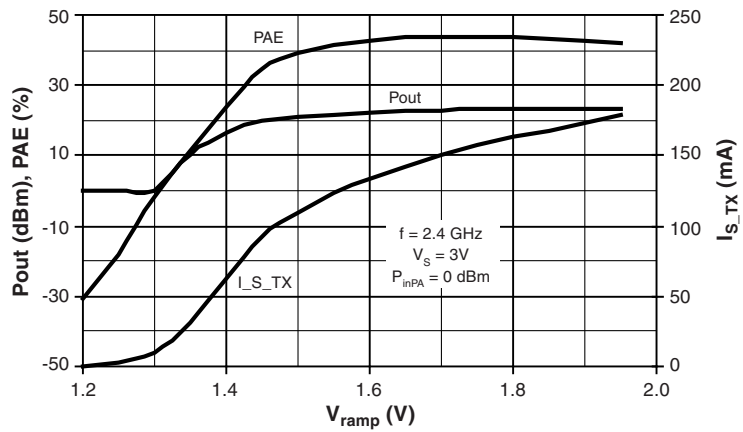

Figure 9-6. PA: Output Power and PAE versus Input Power

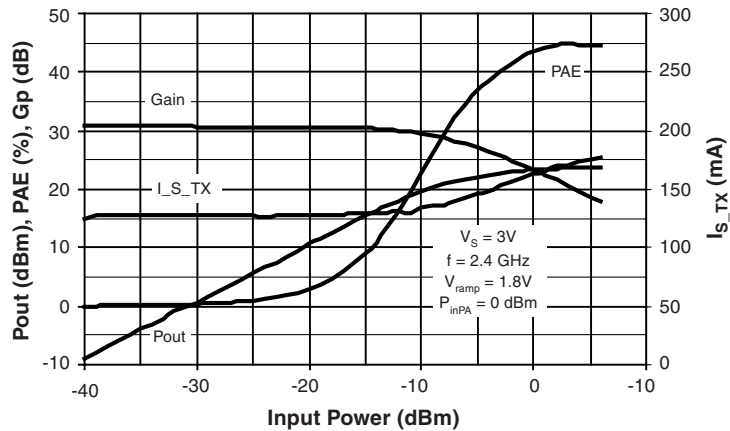

Figure 9-7. PA: Output Power and PAE versus Frequency

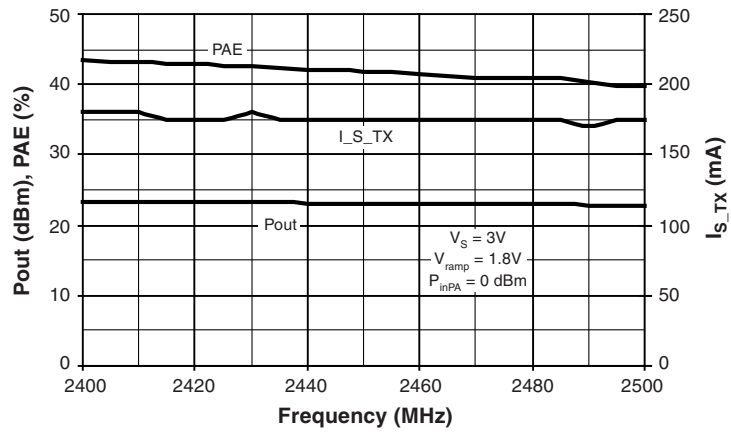

Figure 9-8. LNA: Supply Current versus Temperature

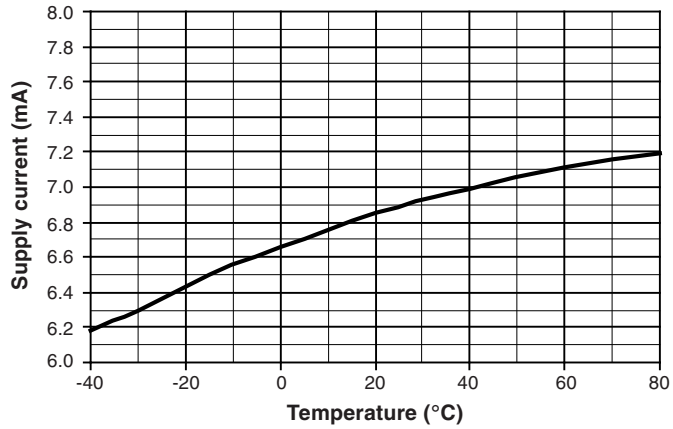

Figure 9-9. PA: P_{out} versus V_{RAMP} and Temperature

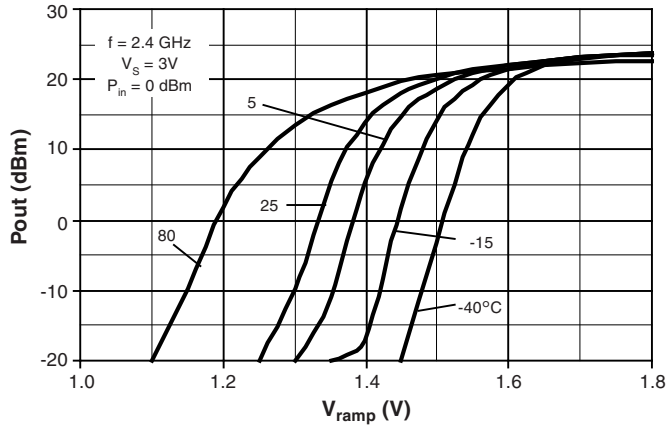
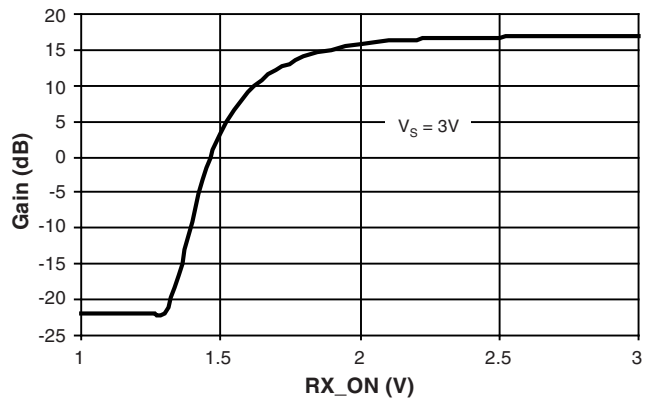

Figure 9-10. LNA Gain (dB) versus RX_ON (V)



10. Input/Output Circuits

Figure 10-1. Input Circuit PA_IN/V1_PA

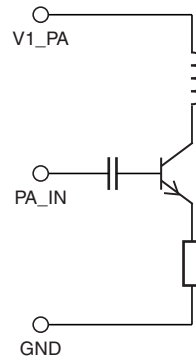

Figure 10-2. Input Circuit RAMP/V1_PA

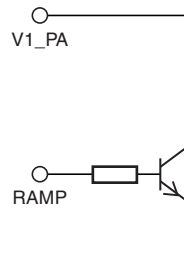

Figure 10-3. Input Circuit V2_PA

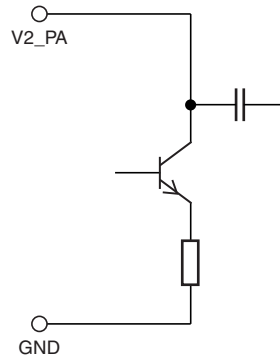

Figure 10-4. Input/Output Circuit V3_PA_OUT

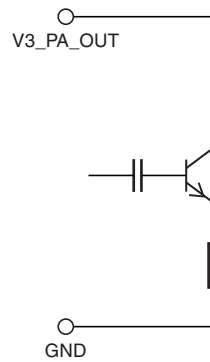

Figure 10-5. Input Circuit SWITCH_OUT/R_SWITCH

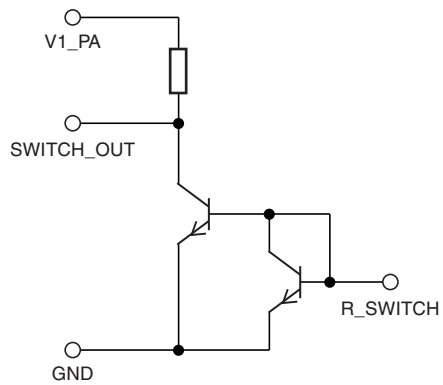

Figure 10-6. Input Circuit LNA_IN/VS_LNA

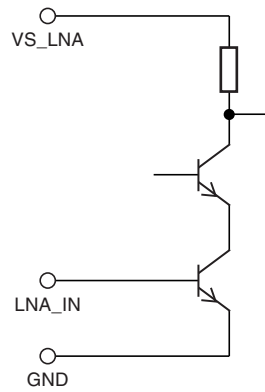

Figure 10-7. Input Circuit PU/RX_ON

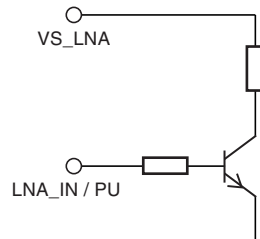

Figure 10-8. Output Circuit LNA_OUT

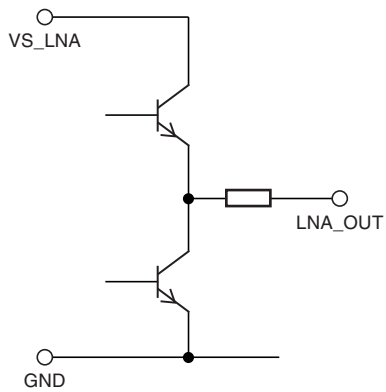
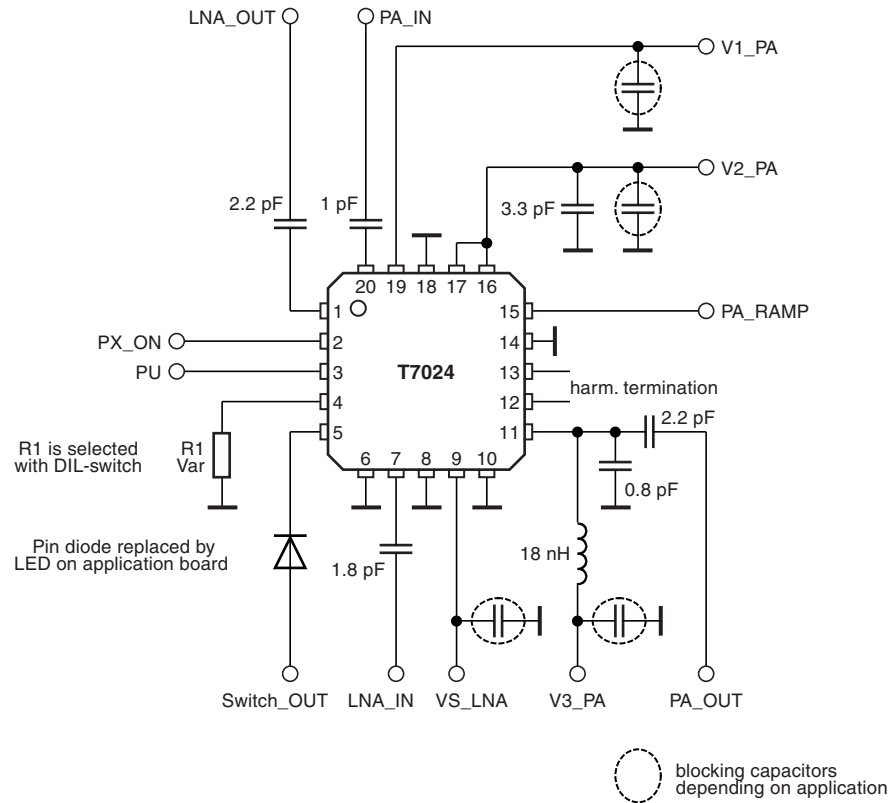

Figure 10-9. Typical Application T7024



11. Ordering Information

Extended Type Number	Package	Remarks	MOQ
T7024-PGPM	QFN20	Taped and reeled Pb free, halogen free	1500 pcs.
T7024-PGQM	QFN20	Taped and reeled Pb free, halogen free	6000 pcs.
Demoboard-T7024-PGM	QFN20	Evaluation board QFN	1

12. Package Information

Package: QFN 20 - 5 x 5
Exposed pad 3.1 x 3.1

Dimensions in mm

Not indicated tolerances ± 0.05

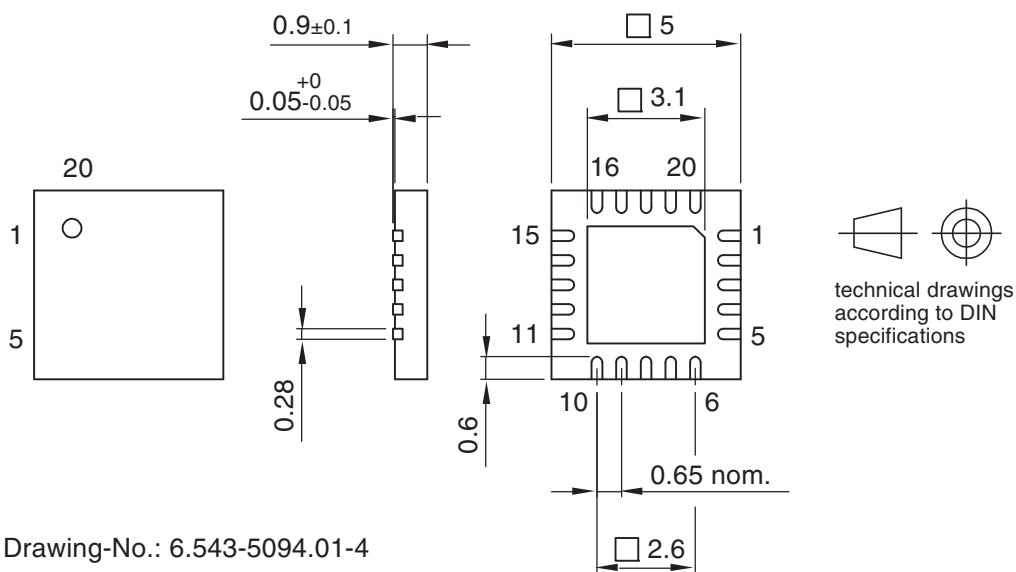

Drawing-No.: 6.543-5094.01-4

Issue: 1; 19.12.02

13. Recommended PCB Land Pattern

Figure 13-1. Recommended PCB Land Pattern

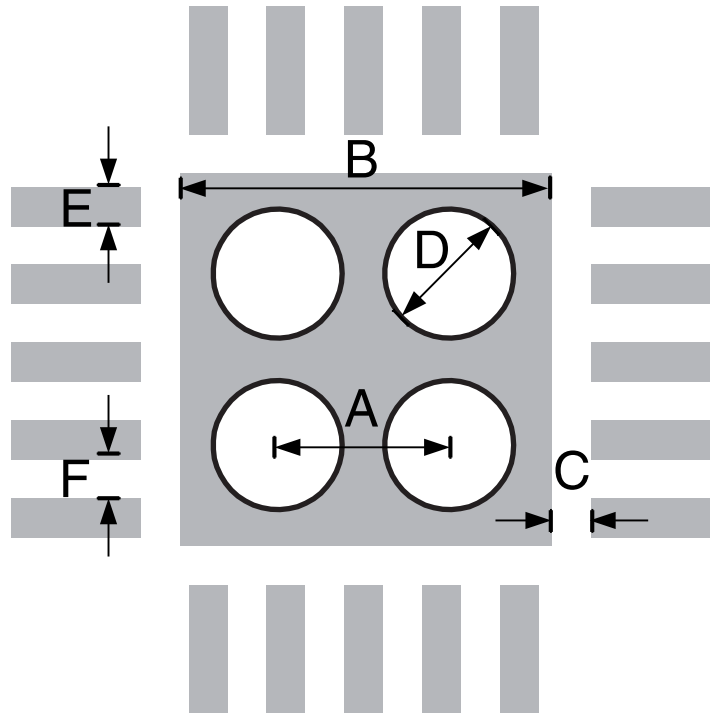

Table 13-1. Recommended PCB Land Pattern Signs

Sign	Description	Size
A	Distance of vias	1.6 mm
B	Size of slug pattern	3.1 mm
C	Distance slug to pins	0.33 mm
D	Diameter of via	1 mm
E	Width of pin pattern	0.3 mm
F	Distance of pin pattern	0.33 mm

14. Revision History

Please note that the following page numbers referred to in this section refer to the specific revision mentioned, not to this document.

Revision No.	History
4533I-BLURF-01/09	<ul style="list-style-type: none"> • PSSO20 package variant deleted
4533H-BLURF-07/07	<ul style="list-style-type: none"> • Put datasheet in a new template • Page 1: Block diagram changed • Page 13: Figure 10-8 changed



Headquarters

Atmel Corporation
2325 Orchard Parkway
San Jose, CA 95131
USA
Tel: 1(408) 441-0311
Fax: 1(408) 487-2600

International

Atmel Asia
Unit 1-5 & 16, 19/F
BEA Tower, Millennium City 5
418 Kwun Tong Road
Kwun Tong, Kowloon
Hong Kong
Tel: (852) 2245-6100
Fax: (852) 2722-1369

Atmel Europe
Le Krebs
8, Rue Jean-Pierre Timbaud
BP 309
78054
Saint-Quentin-en-Yvelines Cedex
France
Tel: (33) 1-30-60-70-00
Fax: (33) 1-30-60-71-11

Atmel Japan
9F, Tonetsu Shinkawa Bldg.
1-24-8 Shinkawa
Chuo-ku, Tokyo 104-0033
Japan
Tel: (81) 3-3523-3551
Fax: (81) 3-3523-7581

Product Contact

Web Site
www.atmel.com

Technical Support
cordless_phone@atmel.com

Sales Contact
www.atmel.com/contacts

Literature Requests
www.atmel.com/literature

Disclaimer: The information in this document is provided in connection with Atmel products. No license, express or implied, by estoppel or otherwise, to any intellectual property right is granted by this document or in connection with the sale of Atmel products. **EXCEPT AS SET FORTH IN ATMEL'S TERMS AND CONDITIONS OF SALE LOCATED ON ATMEL'S WEB SITE, ATMEL ASSUMES NO LIABILITY WHATSOEVER AND DISCLAIMS ANY EXPRESS, IMPLIED OR STATUTORY WARRANTY RELATING TO ITS PRODUCTS INCLUDING, BUT NOT LIMITED TO, THE IMPLIED WARRANTY OF MERCHANTABILITY, FITNESS FOR A PARTICULAR PURPOSE, OR NON-INFRINGEMENT. IN NO EVENT SHALL ATMEL BE LIABLE FOR ANY DIRECT, INDIRECT, CONSEQUENTIAL, PUNITIVE, SPECIAL OR INCIDENTAL DAMAGES (INCLUDING, WITHOUT LIMITATION, DAMAGES FOR LOSS OF PROFITS, BUSINESS INTERRUPTION, OR LOSS OF INFORMATION) ARISING OUT OF THE USE OR INABILITY TO USE THIS DOCUMENT, EVEN IF ATMEL HAS BEEN ADVISED OF THE POSSIBILITY OF SUCH DAMAGES.** Atmel makes no representations or warranties with respect to the accuracy or completeness of the contents of this document and reserves the right to make changes to specifications and product descriptions at any time without notice. Atmel does not make any commitment to update the information contained herein. Unless specifically provided otherwise, Atmel products are not suitable for, and shall not be used in, automotive applications. Atmel's products are not intended, authorized, or warranted for use as components in applications intended to support or sustain life.

© 2009 Atmel Corporation. All rights reserved. Atmel®, logo and combinations thereof, and others are registered trademarks or trademarks of Atmel Corporation or its subsidiaries. Other terms and product names may be trademarks of others.