

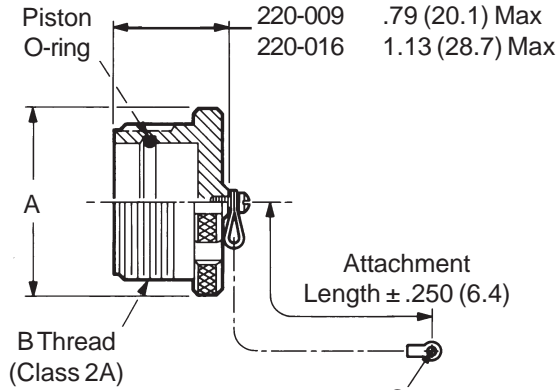

290-009, 290-010 and 290-016 Protective Covers for Standard 220 Series Connectors

PLUG COVER



Series No. 290-009 S 18 03-5
 Shell Style _____
 009 = Standard
 016 = Scoop Proof
 Attachment Symbol _____
 (Table III)

Attachment Length (Inches) _____
 Dash No. (Table II) _____
 Shell Size (Table I) _____

RECEPTACLE COVER

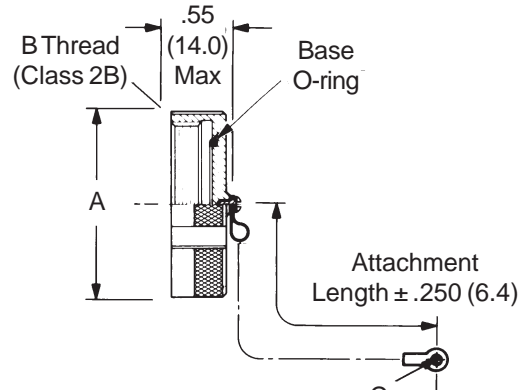

Basic No. 290-010 S 18 03-5
 Attachment Symbol _____
 (Table III)
 Shell Size (Table I) _____

Attachment Length (Inches) _____
 Dash No. (Table II) _____

TABLE I

SHELL SIZE	A MAX	BTHREAD CLASS 2A/2B	TORQUE ± 5 IN. LBS.
10	.900 (22.9)	.750 - .1P - .1L	100
12	1.025 (26.0)	.875 - .1P - .1L	120
14	1.150 (29.2)	1.000 - .1P - .1L	120
16	1.275 (32.4)	1.125 - .1P - .1L	140
18	1.525 (38.7)	1.250 - .1P - .1L	140
20	1.650 (41.9)	1.375 - .1P - .1L	140
22	1.775 (45.1)	1.500 - .1P - .1L	150
24	1.900 (48.3)	1.625 - .1P - .1L	150

PERFORMANCE RATING

The protective covers for Series 22 Geo-Marine connectors provide a hydrostatic sealing capability of up to 5000 psi when mated and tightened to the recommended torque values.

TABLE II

DASH NO.	C DIA
01	.125 (3.2)
02	.140 (3.6)
03	.167 (4.2)
04	.182 (4.6)
05	.191 (4.9)
06	.197 (5.0)

TABLE III

SYMBOL	ATTACHMENT
H	Wire Rope, Teflon Jacket, With Terminal
N	Attachment Omitted
S	#8 Sash Chain, Cres, Passivate
U	Wire Rope, Polyurethane Jacket, With Terminal

REPLACEMENT O-RING PART NUMBERS *

SHELL SIZE	PISTON O-RING	BASE O-RING
10	2-014	2-014
12	2-016	2-016
14	2-018	2-018
16	2-020	2-020
18	2-022	2-022
20	2-024	2-024
22	2-026	2-026
24	2-028	2-028

* Parker O-Ring part numbers.
Compound N674-70 or equivalent.

Prior to use, lubricate O-rings with high grade silicone lubricant (Moly-kote M55 or equivalent).

Metric dimensions (mm) are indicated in parentheses.