



LIGITEK

LIGITEK ELECTRONICS CO.,LTD.
Property of Ligitek Only

DOT MATRIX DIGIT LED DISPLAY (2.3Inch)



Lead-Free Parts

LMD8821/2HURUG-XX-PF

DATA SHEET

DOC. NO : QW0905-LMD8821/2HURUG-XX-PF

REV. : A

DATE : 28 - Oct. - 2009





LIGITEK

LIGITEK ELECTRONICS CO.,LTD.

Property of Ligitek Only

PART NO. LMD8821/2HURUG-XX-PF

Page 1/10

Package Dimensions

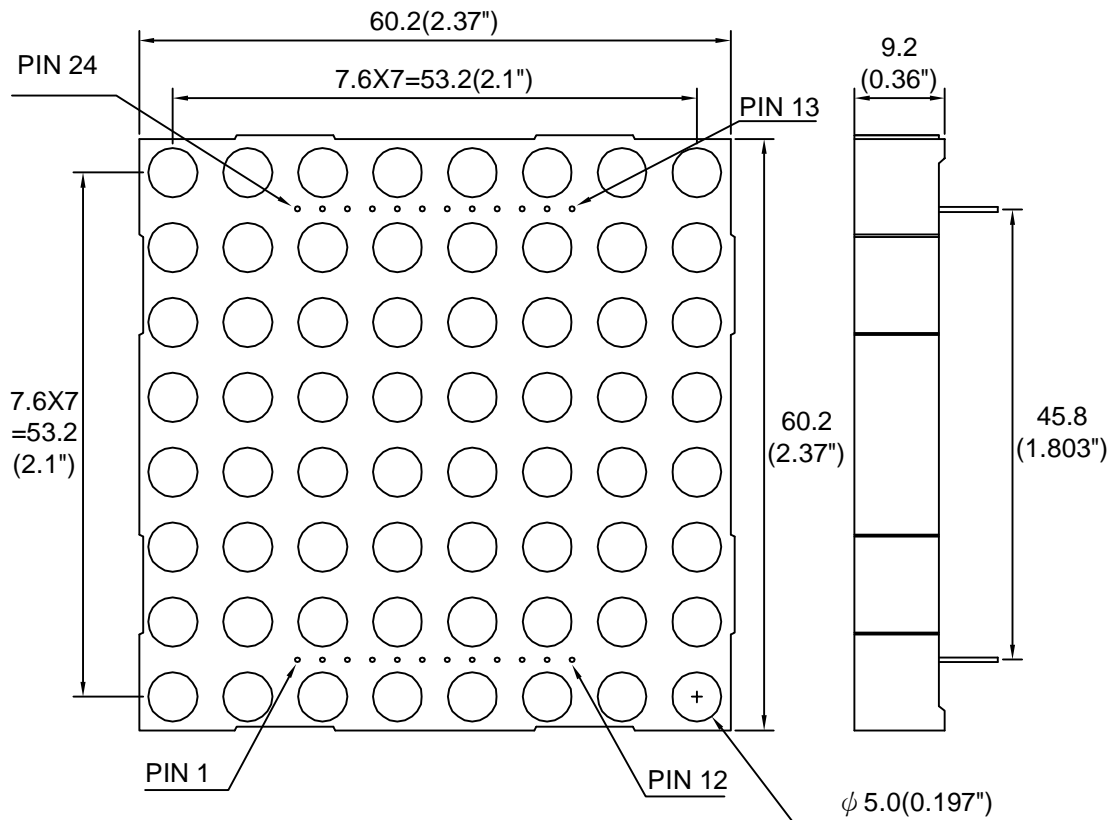

LMD8821/2HURUG-XX-PF
LIGITEK

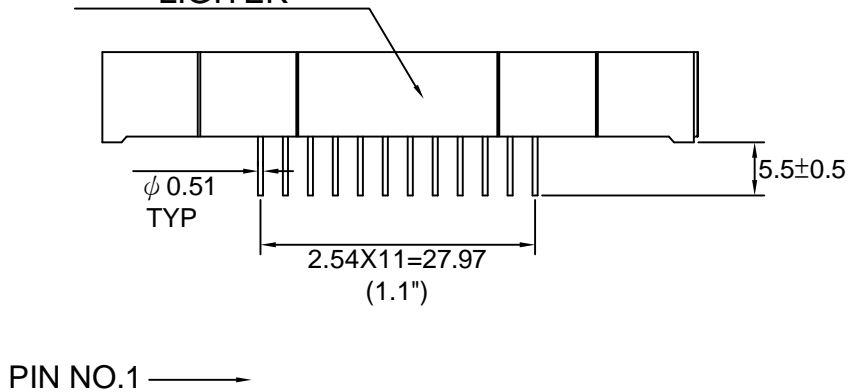

Note : 1.All dimension are in millimeters and (Inch) tolerance is \pm 0.25mm unless otherwise noted.
2.Specifications are subject to change without notice.



Internal Circuit Diagram

LMD8821HURUG-XX-PF

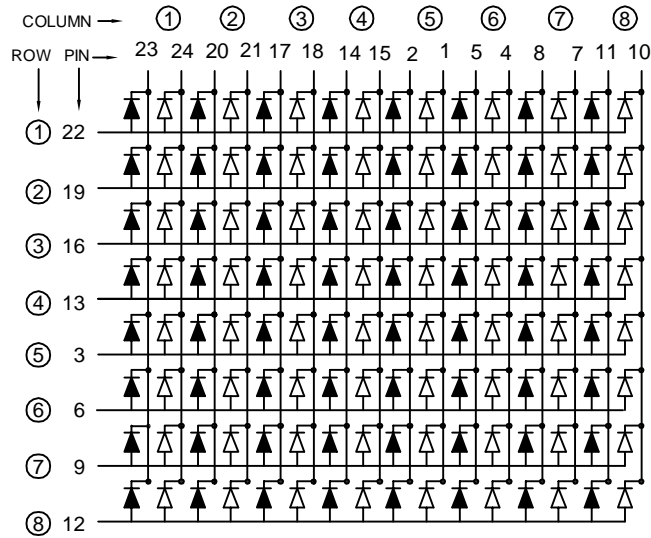

LMD8822HURUG-XX-PF

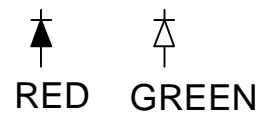
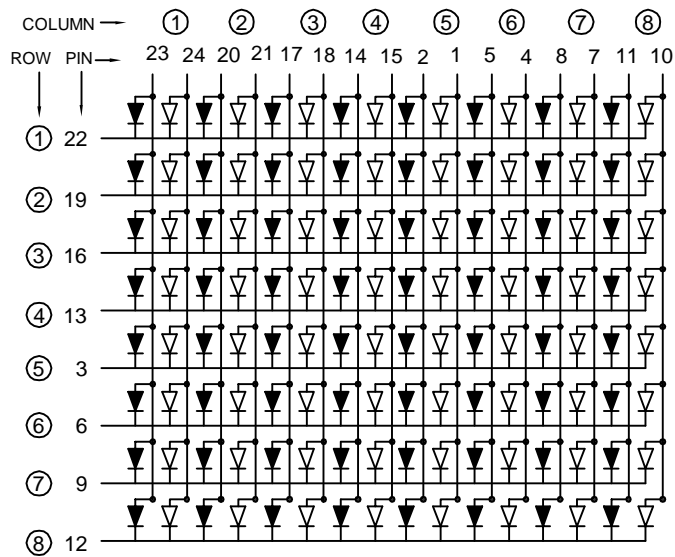



Electrical Connection

PIN NO.	LMD8821HURUG-XX-PF	PIN NO.	LMD8821HURUG-XX-PF
1	Cathode Column 5 (Green)	13	Anode Row 4
2	Cathode Column 5 (Red)	14	Cathode Column 4 (Red)
3	Anode Row 5	15	Cathode Column 4 (Green)
4	Cathode Column 6 (Green)	16	Anode Row 3
5	Cathode Column 6 (Red)	17	Cathode Column 3 (Red)
6	Anode Row 6	18	Cathode Column 3 (Green)
7	Cathode Column 7 (Green)	19	Anode Row 2
8	Cathode Column 7 (Red)	20	Cathode Column 2 (Red)
9	Anode Row 7	21	Cathode Column 2 (Green)
10	Cathode Column 8 (Green)	22	Anode Row 1
11	Cathode Column 8 (Red)	23	Cathode Column 1 (Red)
12	Anode Row 8	24	Cathode Column 1 (Green)

**Electrical Connection**

PIN NO.	LMD8822HURUG-XX-PF	PIN NO.	LMD8822HURUG-XX-PF
1	Anode Column 5 (Green)	13	Cathode Row 4
2	Anode Column 5 (Red)	14	Anode Column 4 (Red)
3	Cathode Row 5	15	Anode Column 4 (Green)
4	Anode Column 6 (Green)	16	Cathode Row 3
5	Anode Column 6 (Red)	17	Anode Column 3 (Red)
6	Cathode Row 6	18	Anode Column 3 (Green)
7	Anode Column 7 (Green)	19	Cathode Row 2
8	Anode Column 7 (Red)	20	Anode Column 2 (Red)
9	Cathode Row 7	21	Anode Column 2 (Green)
10	Anode Column 8 (Green)	22	Cathode Row 1
11	Anode Column 8 (Red)	23	Anode Column 1 (Red)
12	Cathode Row 8	24	Anode Column 1 (Green)



Absolute Maximum Ratings at Ta=25 °C

Parameter	Symbol	Ratings		UNIT
		UR	UG	
Forward Current	IF	40	30	mA
Peak Forward Current Duty 1/10@10KHz	IFP	120	120	mA
Power Dissipation	PD	120	100	mW
Reverse Current @5V	Ir	10	10	μA
Electrostatic Discharge(*)	ESD	---	2000	V
Operating Temperature	Topr	-25 ~ +85		°C
Storage Temperature	Tstg	-25 ~ +85		°C

* Static Electricity or power surge will damage the LED. Use of a conductive wrist band or anti-electrosatic glove is recommended when handing these LED. All devices, equipment and machinery must be properly grounded.

Part Selection And Application Information(Ratings at 25°C)

PART NO	CHIP		common cathode or anode	λ P (nm)	λ D (nm)	Δ λ (nm)	Electrical					IV-M
	Material	Emitted					Vf(v)			Iv(mcd)		
							Min.	Typ.	Max.	Min.	Typ.	
LMD8821HURUG-XX-PF	GaAlAs	Red	Common Cathode	660	--	20	1.5	1.8	2.4	18	26	2:1
	AlGaInP	Green			1.7		2.1	2.6	12.8	18		
LMD8822HURUG-XX-PF	GaAlAs	Red	Common Anode	660	--	20	1.5	1.8	2.4	18	26	
	AlGaInP	Green			1.7		2.1	2.6	12.8	18		

Note : 1.The forward voltage data did not including ±0.1V testing tolerance.
2. The luminous intensity data did not including ±15% testing tolerance.

**Test Condition For Each Parameter**

Parameter	Symbol	Unit	Test Condition
Forward Voltage Per Chip	V _f	volt	I _f =20mA
Luminous Intensity Per Chip	I _v	mcd	I _f =10mA
Peak Wavelength	λP	nm	I _f =20mA
Dominant Wavelength	λD	nm	I _f =20mA
Spectral Line Half-Width	$\Delta \lambda$	nm	I _f =20mA
Reverse Current Any Chip	I _r	μA	V _r =5V
Luminous Intensity Matching Ratio	IV-M		



Typical Electro-Optical Characteristics Curve

UR CHIP

Fig.1 Forward current vs. Forward Voltage

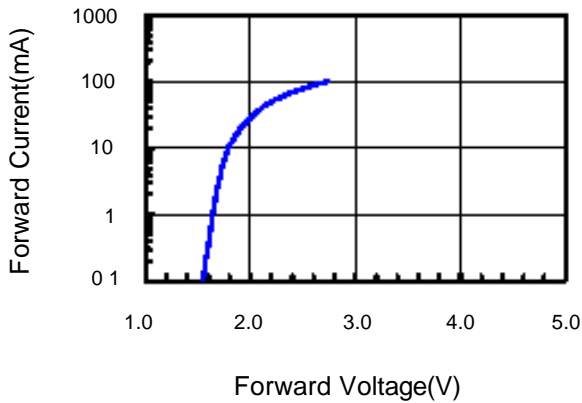

Fig.2 Relative Intensity vs. Forward Current

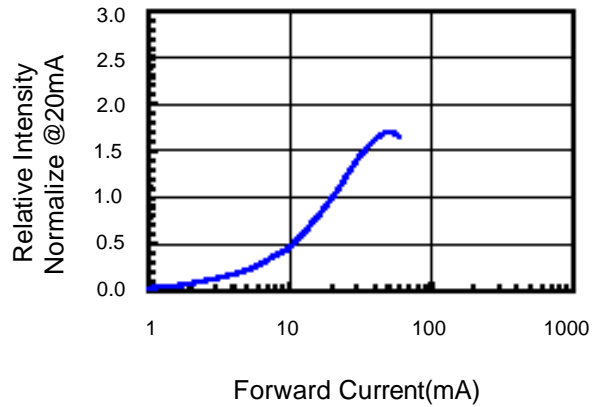

Fig.3 Forward Voltage vs. Temperature

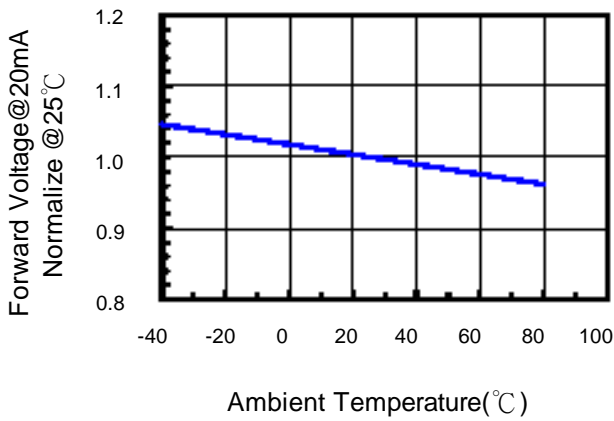

Fig.4 Relative Intensity vs. Temperature

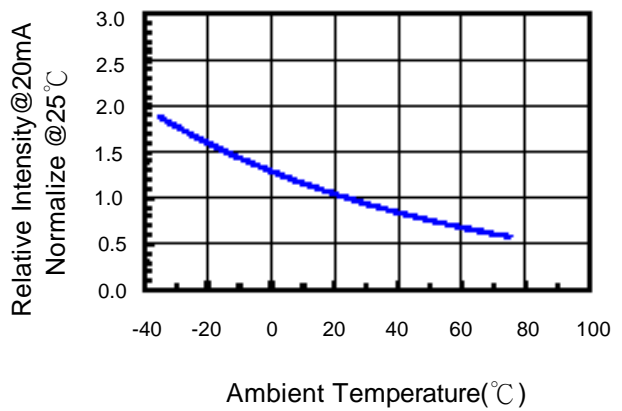
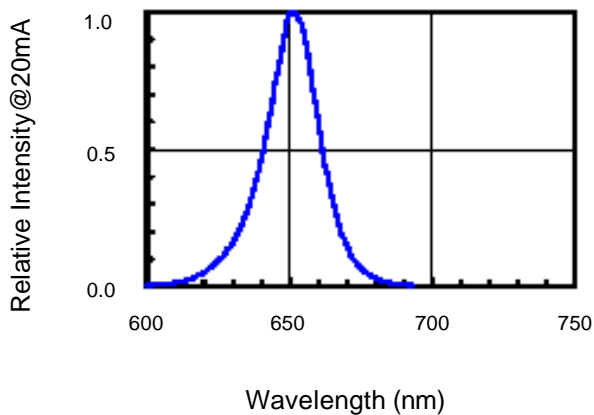

Fig.5 Relative Intensity vs. Wavelength





Typical Electro-Optical Characteristics Curve

UG CHIP

Fig.1 Forward current vs. Forward Voltage

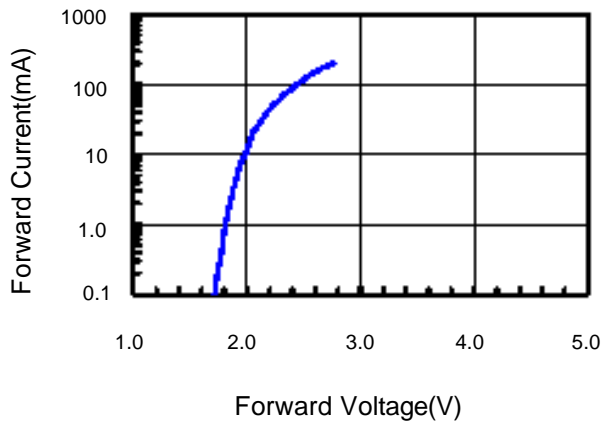

Fig.2 Relative Intensity vs. Forward Current

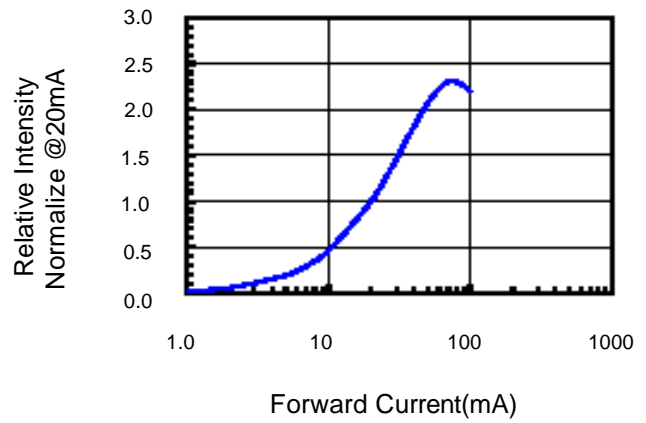

Fig.3 Forward Voltage vs. Temperature

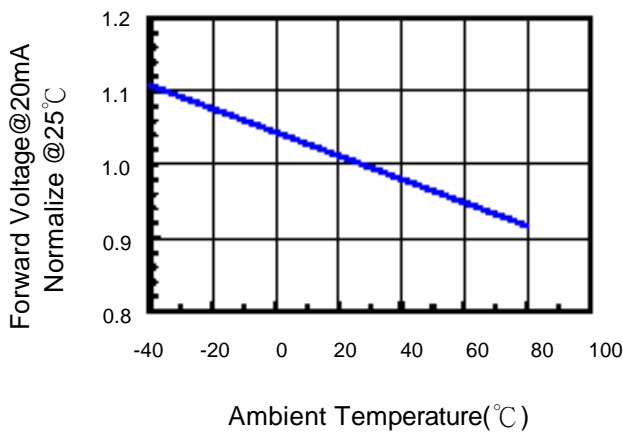

Fig.4 Relative Intensity vs. Temperature

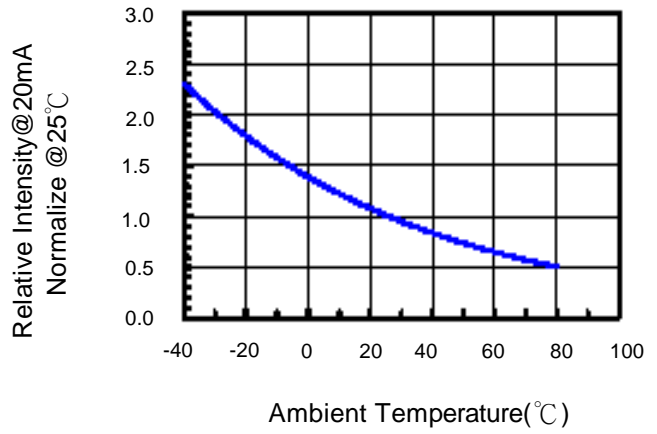
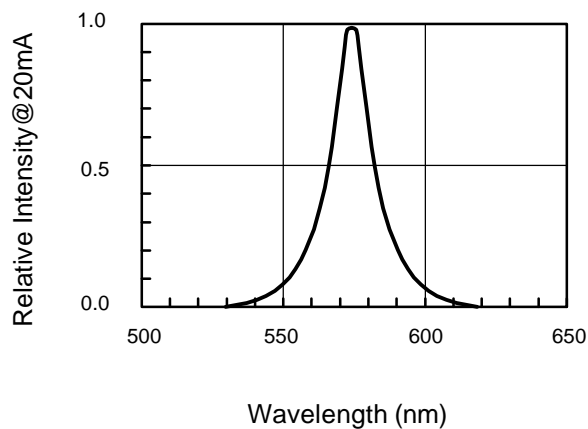

Fig.5 Relative Intensity vs. Wavelength





Soldering Condition(Pb-Free)

1.Iron:

- Soldering Iron:30W Max
- Temperature 350° C Max
- Soldering Time:3 Seconds Max(One time only)
- Distance:Solder Temperature 1/16 Inch Below Seating Plane For 3 Seconds At 260° C

2.Wave Soldering Profile

- Dip Soldering
- Preheat: 120° C Max
- Preheat time: 60seconds Max
- Ramp-up
- 2° C/sec(max)
- Ramp-Down:-5° C/sec(max)
- Solder Bath:260° C Max
- Dipping Time:3 seconds Max
- Distance:Solder Temperature 1/16 Inch Below Seating Plane For 3 Seconds At 260° C

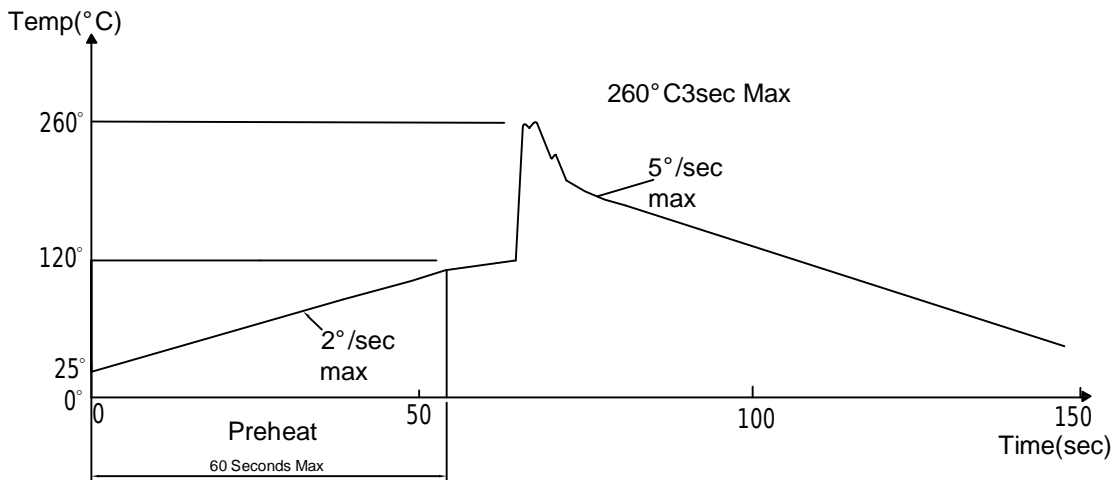

Note: 1.Wave solder should not be made more than one time.
2.You can just only select one of the soldering conditions as above.



Reliability Test:

Test Item	Test Condition	Description	Reference Standard
Operating Life Test	1.Under Room Temperature 2.If=10mA 3.t=1000 hrs (-24hrs, +72hrs)	This test is conducted for the purpose of determining the resistance of a part in electrical and thermal stressed.	MIL-STD-750: 1026 MIL-STD-883: 1005 JIS C 7021: B-1
High Temperature Storage Test	1.Ta=105 °C±5°C 2.t=1000 hrs (-24hrs, +72hrs)	The purpose of this is the resistance of the device which is laid under condition of high temperature for hours.	MIL-STD-883:1008 JIS C 7021: B-10
Low Temperature Storage Test	1.Ta=-40 °C±5°C 2.t=1000 hrs (-24hrs, +72hrs)	The purpose of this is the resistance of the device which is laid under condition of low temperature for hours.	JIS C 7021: B-12
High Temperature High Humidity Test	1.Ta=65 °C±5°C 2.RH=90%~95% 3.t=240hrs ±2hrs	The purpose of this test is the resistance of the device under tropical for hours.	MIL-STD-202:103B JIS C 7021: B-11
Thermal Shock Test	1.Ta=105 °C±5°C & -40 °C±5°C (10min) (10min) 2.total 10 cycles	The purpose of this is the resistance of the device to sudden extreme changes in high and low temperature.	MIL-STD-202: 107D MIL-STD-750: 1051 MIL-STD-883: 1011
Solder Resistance Test	1.T.Sol=260 °C±5°C 2.Dwell time= 10 ±1sec.	This test intended to determine the thermal characteristic resistance of the device to sudden exposures at extreme changes in temperature when soldering the lead wire.	MIL-STD-202: 210A MIL-STD-750: 2031 JIS C 7021: A-1
Solderability Test	1.T.Sol=230 °C±5°C 2.Dwell time=5 ±1sec	This test intended to see soldering well performed or not.	MIL-STD-202: 208D MIL-STD-750: 2026 MIL-STD-883: 2003 JIS C 7021: A-2