

# ASDX Series *A-grade*

## Signal conditioned high precision pressure transducers

---

### FEATURES

- 0...1 to 0...100 psi,  
0...±1 to 0...±15 psi
- Absolute, gage or differential pressure
- 0.5 to 4.5 V ratiometric output
- Precision ASIC conditioning
- Temperature compensated
- Total accuracy ±0.5 to ±1.0 %FSS

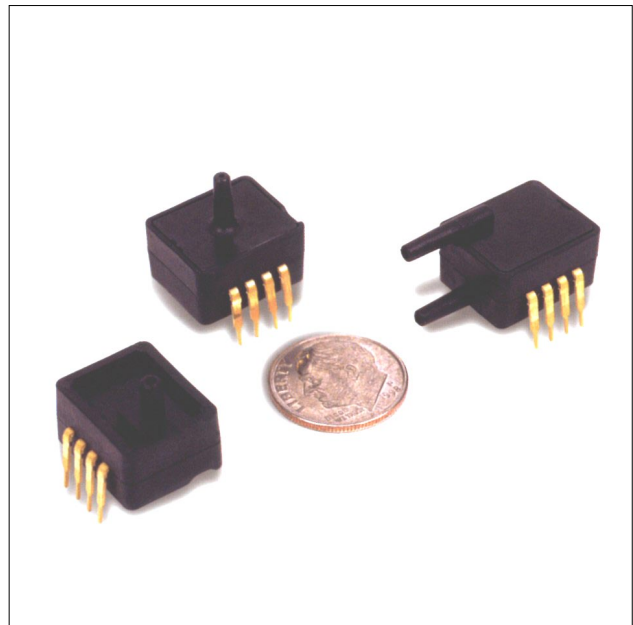

### SPECIFICATIONS

#### Maximum ratings

Supply voltage $V_s$	4.75 V to 5.25 $V_{DC}$ max. 6.50 $V_{DC}$
Output current	
Sink	2 mA
Source	2 mA
Lead temperature (2 - 4 sec.)	250°C
Temperature ranges	
Compensated	0 to +85 °C
Operating	-20 to +105 °C
Storage	-40 to +125 °C
Vibration	10 g at 20 - 2000 Hz
Shock	100 g for 11 ms

**Caution!** The sensor is not reverse polarity protected.

Incorrect applications of excitation voltage or ground to the wrong pin can cause electrical failure.

Application of supply voltage above the maximum can cause electrical failure.

### ELECTRICAL CONNECTION

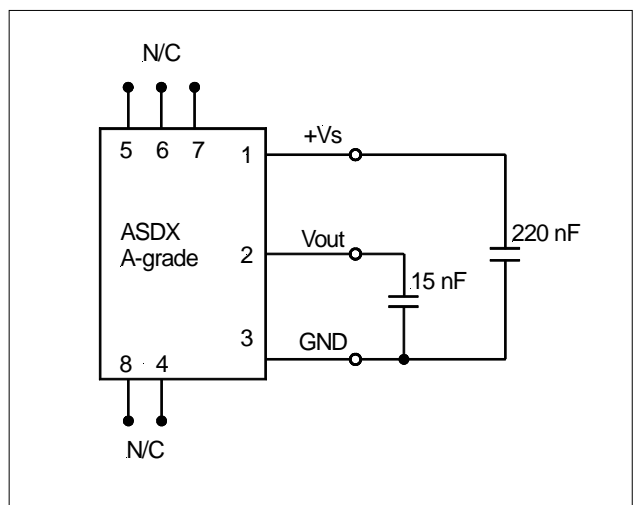

**Note:** Capacitor 220 nF required between +Vs and GND and 15 nF between Vout and GND.

It is important to place the capacitors as close to the pins as possible!

Pins 4, 5, 6, 7 and 8 are internal device connections and should not be connected for any reason!

# ASDX Series *A-grade*

## Signal conditioned high precision pressure transducers

---

### PRESSURE RANGES SPECIFICATIONS

( $V_s = 5.0 V_{DC}$ ,  $T_A = 25^\circ C$ )

Part number	Pressure range	Burst pressure <sup>1</sup>		Sensitivity (typ.)
ASDX015A24R-A	0 to 15	psi(a)	30	0.27
ASDX030A24R-A	0 to 30		60	0.13
ASDX100A24R-A	0 to 100		150	0.04
ASDX001G24R-A / D44R-A	0 to 1	psi(g,d)	5	4.00
ASDX005G24R-A / D44R-A	0 to 5		20	0.80
ASDX015G24R-A / D44R-A	0 to 15		30	0.27
ASDX030G24R-A / D44R-A	0 to 30		60	0.13
ASDX100G24R-A / D44R-A	0 to 100		150	0.04
ASDX001D44D-A	0 to $\pm 1$		5	2.00
ASDX005D44D-A	0 to $\pm 5$		20	0.40
ASDX015D44D-A	0 to $\pm 15$		30	0.13

#### Specification notes:

1. If maximum burst pressure is exceeded, even momentarily, the package may leak or burst, or the pressure sensing die may fracture.
2. Full Scale Span (FSS) is the algebraic difference between the output signal for the highest and lowest specified pressure. Span is ratiometric to the supply voltage.
3. Total accuracy is the combined error of offset and span calibration, linearity, pressure hysteresis and temperature effects. Linearity is the measured deviation based on a straight line.  
Hysteresis is the maximum output difference at any point within the operating pressure range for increasing and decreasing pressure. Calibration errors include the deviation of offset and full scale from nominal values.
4. Delay time between sampling and signal change at the output.
5. The smallest change in the output voltage, given any change in pressure.

# ASDX Series *A-grade*

## Signal conditioned high precision pressure transducers

---

### PERFORMANCE CHARACTERISTICS

0.5 to 4.5 ratiometric output ( $V_S = 5.0 V_{DC}$ ,  $T_A = 25^\circ C$ )

All ASDX...A24R-A, ...G24R-A, ...D44R-A

Characteristics		Min.	Typ.	Max.	Units
Zero pressure offset	ASDX001...	0.46	0.50	0.54	V
	all others	0.48	0.50	0.52	
Full scale span (FSS) <sup>2</sup>			4.00		
Full scale output	ASDX001...	4.46	4.50	4.54	
	all others	4.48	4.50	4.52	
Total accuracy (0 to 85°C) <sup>3</sup>	ASDX001...			±1.0	
	all others			±0.5	
Sample rate		100			Hz
Response delay <sup>4</sup>		2.73		14.11	ms
Quantization step <sup>5</sup>			2		mV
Current consumption			6		mA

All ASDX...D44D-A

Characteristics		Min.	Typ.	Max.	Units	
Zero pressure offset	ASDX001...	2.46	2.50	2.54	V	
	all others	2.48	2.50	2.52		
Full scale span (FSS) <sup>2</sup>			4.00			
Output	at max. specified pressure	ASDX001...	4.46	4.50		4.54
		all others	4.48	4.50		4.52
	at min. specified pressure	ASDX001...	0.46	0.50		0.54
		all others	0.48	0.50	0.52	
Total accuracy (0 to 85°C) <sup>3</sup>	ASDX001...			±1.0	%FSS	
	all others			±0.5		
Sample rate		100			Hz	
Response delay <sup>4,5</sup>		2.73		14.11	ms	
Quantization step <sup>5</sup>			2		mV	
Current consumption			6		mA	

# ASDX Series *A-grade*

## Signal conditioned high precision pressure transducers

### PHYSICAL DIMENSIONS

#### D4 package

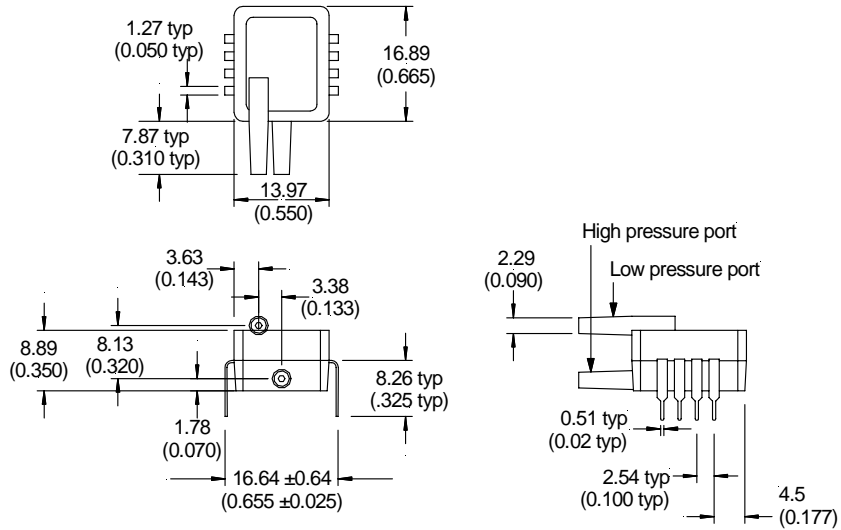

#### G2 package

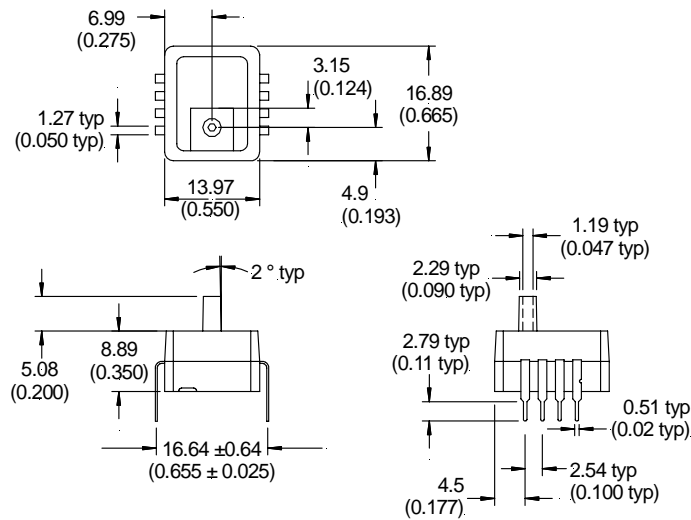

#### A2 package

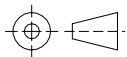
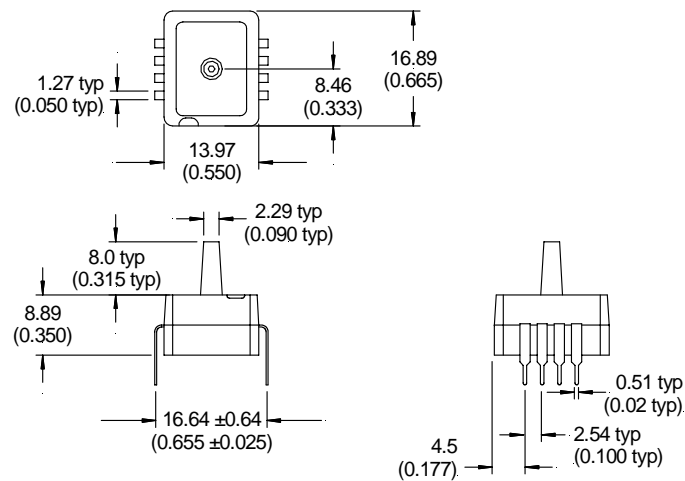

third angle projection

dimensions in mm (inches)

# ASDX Series *A-grade*

## Signal conditioned high precision pressure transducers

### ELECTRICAL CONNECTIONS

**ASDX...D4...**

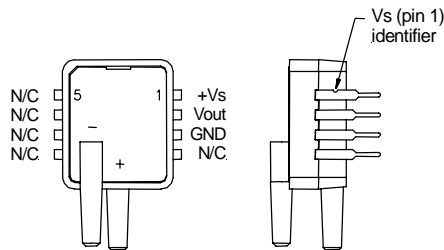

**ASDX...G24R-A**

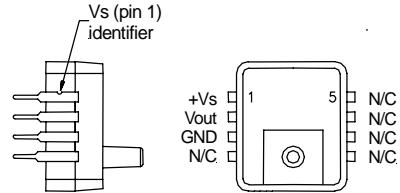

**ASDX...A24R-A**

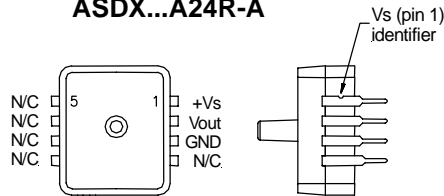

**Note:**

**Pins 4, 5, 6, 7 and 8 are internal device connections and should not be connected for any reason!**

### ORDERING INFORMATION

Pressure range	Absolute	Gage	Differential/Gage	
0 to 1 psi		ASDX001G24R-A	ASDX001D44R-A	
0 to 5 psi		ASDX005G24R-A	ASDX005D44R-A	
0 to 15 psi		ASDX015A24R-A	ASDX015G24R-A	ASDX015D44R-A
0 to 30 psi		ASDX030A24R-A	ASDX030G24R-A	ASDX030D44R-A
0 to 100 psi		ASDX100A24R-A	ASDX100G24R-A	ASDX100D44R-A
0 to ±1 psi			ASDX001D44D-A	
0 to ±5 psi			ASDX005D44D-A	
0 to ±15 psi			ASDX015D44D-A	

**Other pressure ranges or calibrations are available on request**

Sensortech reserves the right to make changes to any products herein. Sensortech does not assume any liability arising out of the application or use of any product or circuit described herein, neither does it convey any license under its patent rights nor the rights of others.