

144 x 155,8 x 209,5 mm

ETRI®

AC Centrifugal Blowers

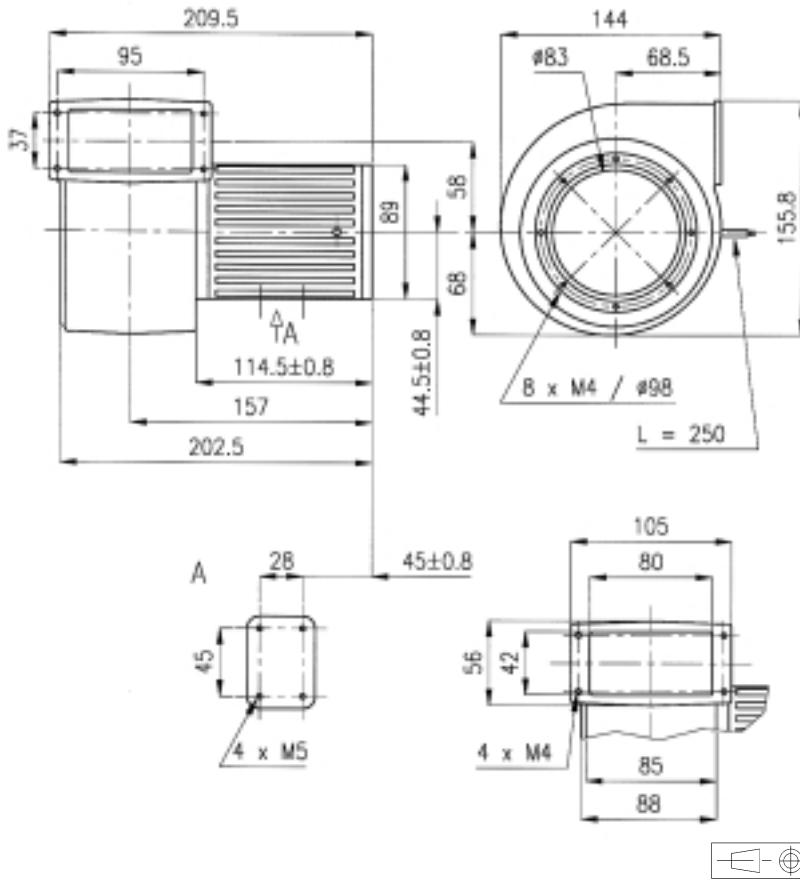

Approvals

GAM T1 LISTED

Life expectancy

L-10 LIFE AT 40°C:
25 000 hours

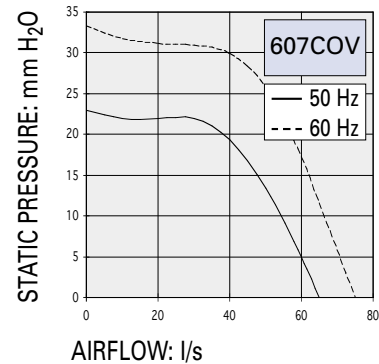

AC Motor

Housing material: aluminium
Wheel material: steel plate
Weight: 3,75 kg
Bearing system: ball bearings

Connection: flying leads

Available with:
- safety switch (see picture)

Part number	Nominal voltage	Airflow	Noise level	Nominal speed	Frequency	Phases	Capacitor (not included)	Input power	Nominal current	Starting current	Operating temperature	
	V										l/s	dB(A)
607COV016DC13	220	65	63	2900	50	3		50	245	1250	- 10	70
	380	65	63	2900	50	3		50	145	750	- 10	70
	220	72	66	3300	60	3		72	250	1150	- 10	70
	380	72	66	3300	60	3		72	145	700	- 10	70
	220	65	63	2900	50	1	4,7	54	250	1100	- 10	70
	380	65	63	2900	50	1	1,47	54	145	650	- 10	70
	220	72	66	3300	60	1	4,7	83	370	1000	- 10	70
	380	72	66	3300	60	1	1,47	83	215	600	- 10	70

Additional versions:

Salt spray protected - shock and vibration protected - marine specifications - wide temperature range

Accessories:

See pages: 157, 160 and 163