

# SPECIFICATION FOR APPROVAL

REF :

PAGE: 1

PROD. NAME	SMD POWER INDUCTOR	ABC'S DWG NO.	SB2207□□□□L□-□□□
		ABC'S ITEM NO.	

**. CONFIGURATION & DIMENSIONS :**

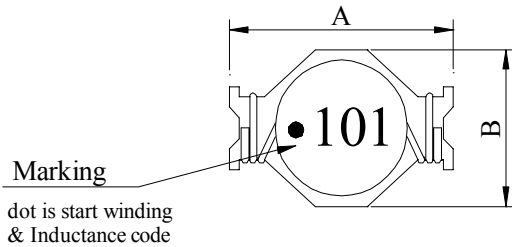

- A : 22.0 ±0.3 m/m
- B : 15.0 ±0.3 m/m
- C : 7.0 ±0.4 m/m
- D : 15.0 typ. m/m
- E : 2.3 typ. m/m
- F : 8.0 typ. m/m

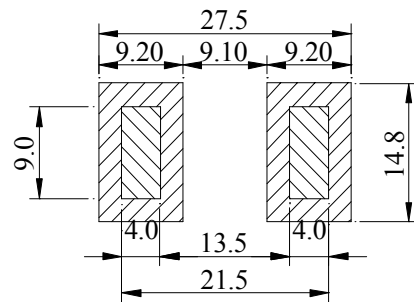
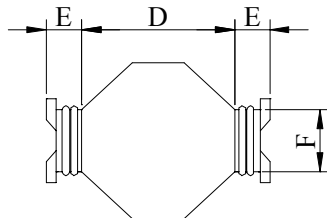
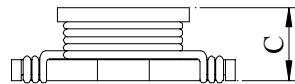

( PCB Pattern )

**. SCHEMATIC DIAGRAM :**

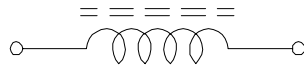

**. MATERIALS :**

- a . Core : Ferrite DR core
- b . Wire : Enamelled copper wire ( class F )
- c . Base : Hitachi phenolic CP-J-8700
- d . Adhesive : Epoxy resin
- e . Terminal : Cu/Sn
- f . Remark : Products comply with RoHS' requirements

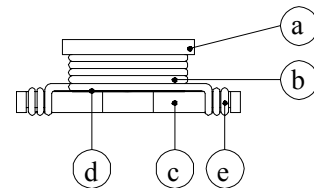

Peak Temp : 260 max.  
 Max time above 230 : 50sec max.  
 Max time above 200 : 70sec max.

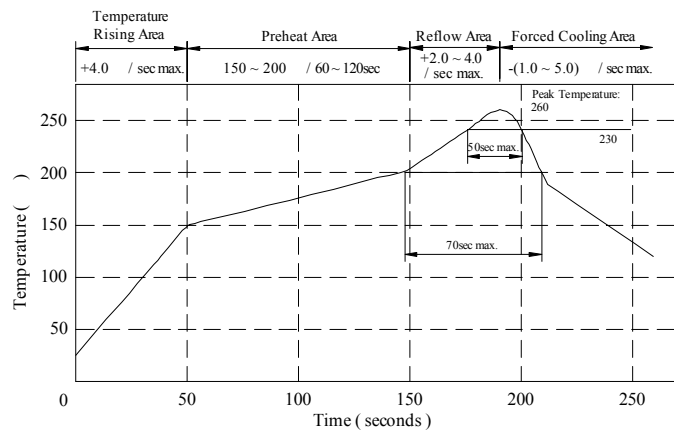

**. GENERAL SPECIFICATION :**

- a . Temp. rise : 40 max.
- b . Storage temp. : -40 ~ +125
- c . Operating temp. : -40 ~ +105
- d . Resistance to solder heat : 260 . 10 secs.

AE-001A

# SPECIFICATION FOR APPROVAL

REF :

PAGE: 2

PROD. NAME	SMD POWER INDUCTOR	ABC'S DWG NO.	SB2207□□□□L□-□□□
		ABC'S ITEM NO.	

**ELECTRICAL CHARACTERISTICS :**

DWG No.	Inductance (μH) 0.1 V / 100 KHz	RDC (mΩ) ±20%	Irms (A) max. T = 40	Isat (A) typ. L / LOA = 10%
SB2207R80ML□-□□□	0.80±20%	2.3	16.0	35.0
SB22071R2ML□-□□□	1.20±20%	3.2	15.0	30.0
SB22071R8ML□-□□□	1.80±20%	4.5	13.0	25.0
SB22072R7ML□-□□□	2.70±20%	7.0	10.0	20.0
SB22073R3ML□-□□□	3.30±20%	7.8	9.0	17.0
SB22074R7ML□-□□□	4.70±20%	8.8	8.5	15.0
SB22075R6ML□-□□□	5.60±20%	12.4	7.8	14.0
SB22076R8ML□-□□□	6.80±20%	14.2	7.5	12.0
SB22078R2ML□-□□□	8.20±20%	15.5	7.0	11.0
SB2207100ML□-□□□	10.00±20%	17.2	6.5	10.0
SB2207120YL□-□□□	12.00±15%	23.6	5.5	9.5
SB2207150YL□-□□□	15.00±15%	28.8	5.0	9.0
SB2207180YL□-□□□	18.00±15%	33.0	4.6	8.0
SB2207220YL□-□□□	22.00±15%	39.4	4.0	6.5
SB2207270YL□-□□□	27.00±15%	43.5	3.8	6.0
SB2207330YL□-□□□	33.00±15%	58.4	3.4	5.5
SB2207390KL□-□□□	39.00±10%	65.0	3.2	5.2
SB2207470KL□-□□□	47.00±10%	91.2	2.8	5.0
SB2207560KL□-□□□	56.00±10%	96.5	2.6	4.5
SB2207680KL□-□□□	68.00±10%	112.0	2.4	4.0
SB2207820KL□-□□□	82.00±10%	144.0	2.2	3.5
SB2207101KL□-□□□	100.00±10%	168.0	2.0	3.0

- 1). □ : Packaging information... A: ] Bulk B: ] Taping Reel
- 2). "-□□□": Reference code
- 3). Irms base on Temp. rise 40 max.
- 4). Isat base on L/LOA=10% typ.
- 5). L,Q Test Frequency : 100KHz / 0.1V

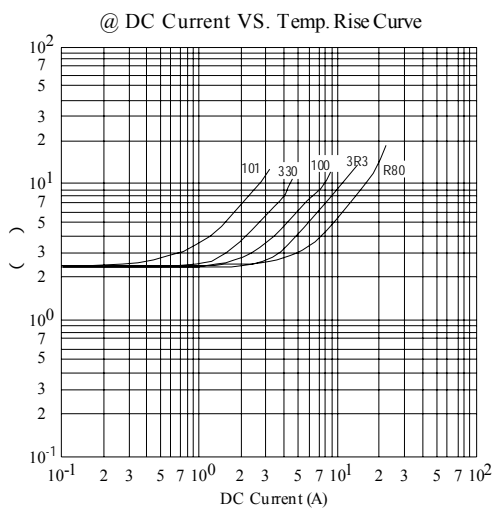
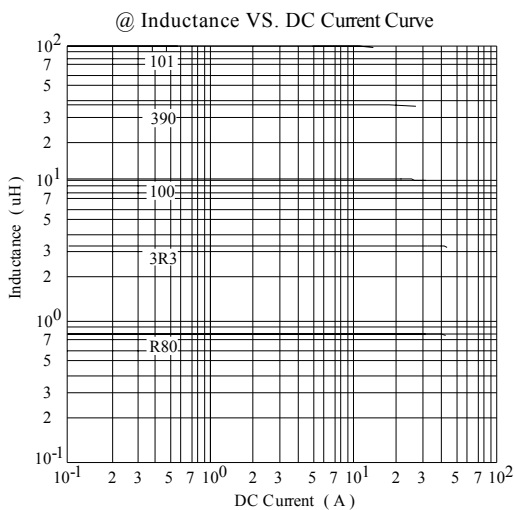

AE-001A



# SPECIFICATION FOR APPROVAL

REF :

PAGE: 3

PROD. NAME	SMD POWER INDUCTOR	ABC'S DWG NO.	SB2207□□□□L□-□□□
		ABC'S ITEM NO.	

**PACKAGING INFORMATION :**

1. Configuration :

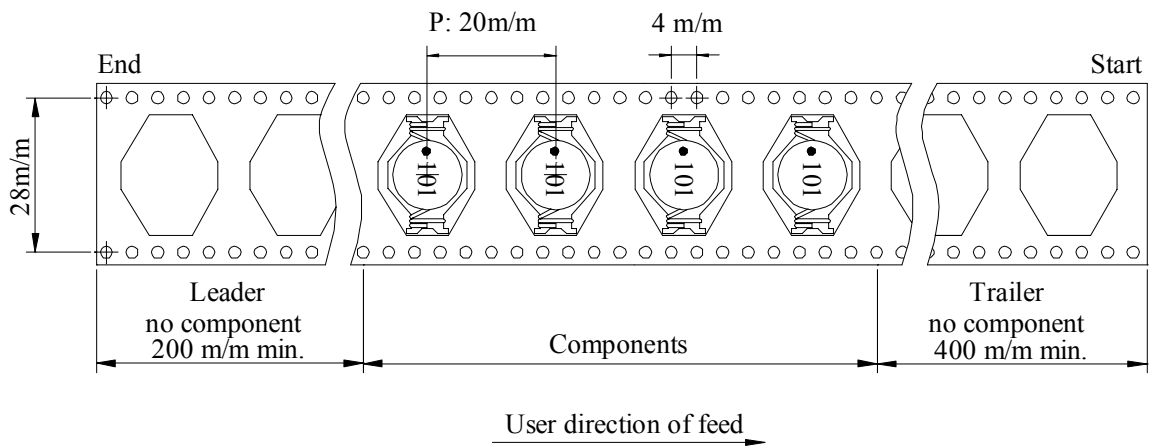
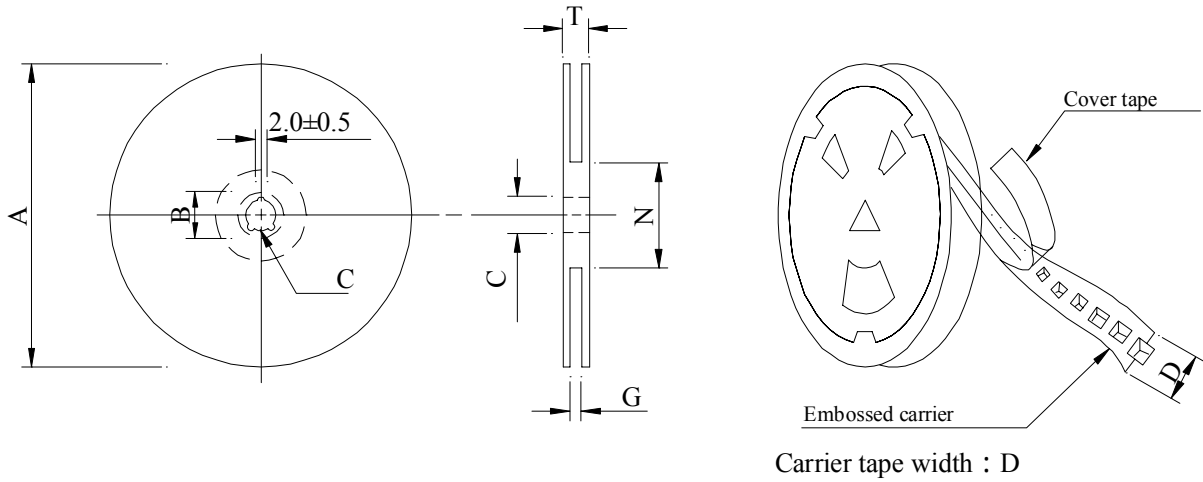

2. Dimensions : (m/m)

Style	A	B	C	D	G	N	T
13 - 32	330	21±0.8	13±0.5	32	34 <sup>+0</sup>	100 <sup>-0</sup>	38.4

3. Q'TY & G.W. Per package :

Series	Inner : Reel			Outer : Carton		
	Q'TY (pcs)	G.W. (gw)	Style	Q'TY (pcs)	G.W. (kg)	Size (cm)
SB2207	250	1,250	13 - 32	1,000	6.8	40 x 40 x 24

AE-001A

# SPECIFICATION FOR APPROVAL

REF :

PAGE: 4

PROD. NAME	SMD POWER INDUCTOR	ABC'S DWG NO.	SB2207□□□□L□-□□□
		ABC'S ITEM NO.	

### . DWGING NUMBER EXPRESSION :

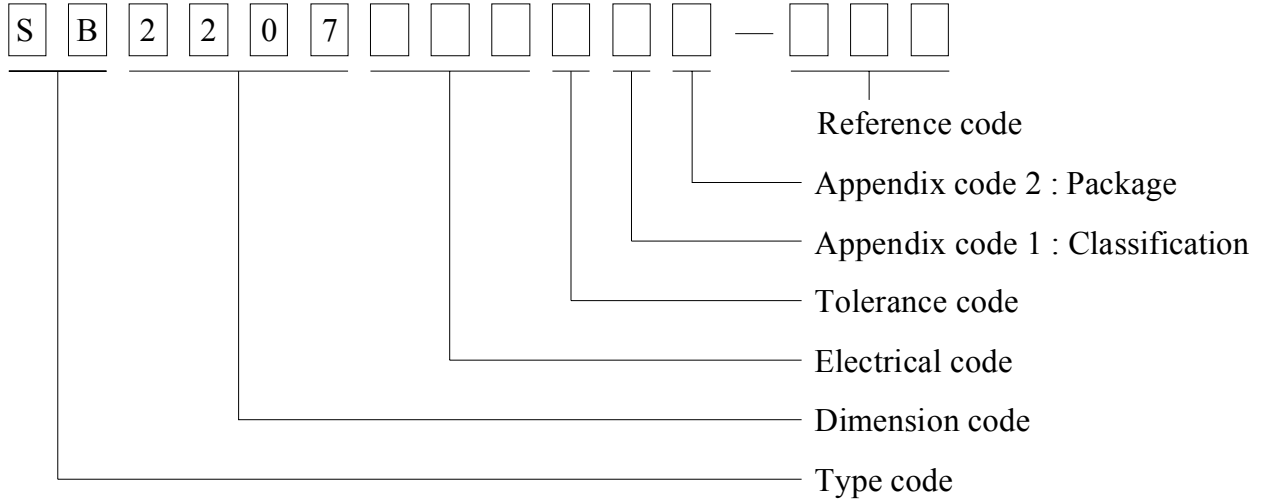

#### Appendix code 1 : Product Classification

- L : Lead Free Standard products comply with RoHS' requirements
- 1 ~ 9 : Lead Free Special products comply with RoHS' requirements

#### Appendix code 2 : Package Information

Code	Inner package	Inner package Q'TY	Remark
A	T.B.D.	T.B.D.	
B	T / R ( Reel package )	250 pcs	

# SPECIFICATION FOR APPROVAL

REF :

PAGE: 5

PROD. NAME	SMD POWER INDUCTOR	ABC'S DWG NO.	SB2207□□□□L□-□□□
		ABC'S ITEM NO.	

**. RELIABILITY TEST :**

Test item	Specification	Test condition												
Solderability	More than 90% of the terminal electrode shall be covered With fresh solder.	Preheat : 150±25 for 60 seconds Solder : Sn96.5 / Ag3 / Cu0.5 or equivalent Solder temp. : 235±5 Flux : Rosin Dip time : 4±1 seconds												
Thermal shock test ( Temp. cycle )	Inductance shall not change more than ±20%	<table style="width: 100%; border: none;"> <tr> <td style="text-align: center;">Room temp.</td> <td style="text-align: center;">—————&gt;</td> <td style="text-align: center;">-25±2</td> </tr> <tr> <td style="text-align: center;">15 minutes</td> <td></td> <td style="text-align: center;">30 minutes</td> </tr> </table> <table style="width: 100%; border: none;"> <tr> <td style="text-align: center;">Room temp.</td> <td style="text-align: center;">—————&gt;</td> <td style="text-align: center;">85±2</td> </tr> <tr> <td style="text-align: center;">15 minutes</td> <td></td> <td style="text-align: center;">30 minutes</td> </tr> </table> Total : 50 cycles	Room temp.	—————>	-25±2	15 minutes		30 minutes	Room temp.	—————>	85±2	15 minutes		30 minutes
Room temp.		—————>	-25±2											
15 minutes			30 minutes											
Room temp.		—————>	85±2											
15 minutes		30 minutes												
Humidity Resistance test	Temperature : 40±2 Humidity : 90 ~ 95% Applied current : Per spec. Time : 500 hours													
High temp. Resistance test	Temperature : 105±2 Applied current : Per spec. Time : 500 hours													

AE-001A



# SPECIFICATION FOR APPROVAL

REF :

PAGE: 6

PROD. NAME	SMD POWER INDUCTOR	ABC'S DWG NO.	SB2207□□□□L□-□□□
		ABC'S ITEM NO.	

**UL CARD :**

**OBMW2** September 8, 2000  
**Magnet Wire-Component**

**JUNG SHING WIRE CO LTD** E174837  
 231 CHUNG CHENG RD, SEC 3 JEN-TEH HSIANG, TAINAN  
 HSIEN TAIWAN

Mtl Dsg	Mark Dsg	BC	Coat Typ		ANSI Type	Temp Class
AIW	---	Polyamideimide	---	OC	MW81-C	220
CFUEWB	---	Polyurethane	---	---	MW75C	130
EIAIW	---	Polyesterimide	---	Polyamideimide	MW35C	200
EILOCKY	---	Polyesterimide	---	Polyamide	---	180
EILOCKW	---	Polyesterimide	---	Modified Epoxy	---	200
EIW	---	Polyesterimide	---	---	---	220
EIW-2	---	Polyesterimide	---	---	MW74-C	200
FL.EILOCKY	---	Modified Polyester	---	Polyamide	---	155
LSFFW	---	Polyurethane	---	---	MW79-C	155
LSUEW	---	Polyurethane	---	---	---	130
PEW	---	Polyester	---	---	---	155
PEY	---	Polyester	---	Nylon	MW24-C	155
SF.FLW	---	Modified Polyester	---	---	MW26C	155
SF.EIW	---	<b>Polyesterimide</b>	---	---	MW77C	180
SF.BY@	---	Modified Polyester	---	Nylon	MW27-C	155
SF.FLY@	---	Modified Polyester	---	Nylon	MW27-C	155
SF.BLOCKBS	---	Modified Polyester	---	Modified Polyamide	---	155
SF.EILOCKY#	---	Polyesterimide	---	Polyamide	---	180
SF.EILOCKBS	---	Polyesterimide	---	Modified Polyamide	---	180
SF.BW@	---	Modified Polyester	---	---	MW26C	155
SFFW	---	Polyurethane	---	---	MW79	155

287806002 Page 1 of 2

A not-for-profit organization dedicated to public safety and committed to quality service

Mtl Dsg	Mark Dsg	BC	Coat Typ		ANSI Type	Temp Class
SFFY	---	Polyurethane	---	Polyamide	MW80C	155
UEW-1	---	Polyurethane	---	---	MW2-C	105
UEW-2	---	Polyurethane	---	---	---	130
UEW-4	---	Polyurethane	---	---	MW75C	130
UEY	---	Polyurethane	---	Nylon	MW28-C	130
UEY-2	---	Polyurethane	---	Polyamide	MW28-C	130

@-May be suffixed by LZ; # - May be suffixed by LZ, EL or LZL.  
 LZ - Signifies magened wires twisted together; EL - signifies base coated magnet wire laid parallel with top coat applied overall; LZL - signifies base coated magnet wire twisted together and covered with top coat overall.

Marking: Company name or trademarks **JSW** or 榮星電線, material designation or marked designation on packaed or reel, and Recognized Component Mark.

See General Information Preceding These Recognitions  
 For use only in equipment where the acceptability of the combination is determined by Underwriters Laboratories Inc.

287806002 Page 2 of 2

OBMW2/E174837  
September 8, 2000

**QMFZ2** November 6, 1989  
**Component-Plastics**

**HITACHI CHEMICAL CO LTD** E42956 (R)  
 (F-cont. from EI card)

CP-J-8700	BK	0.48	94V-0	150	150	150	—	—	—	—
		0.76	94V-0	150	150	150	2	1	0	—
		1.60	94V-0	150	150	150	2	1	0	—
		3.12	94V-0	150	150	150	0	1	0	4 3

Report : March 10, 1980. (Cont. on F1 card)

418315008 N7047 **Underwriters Laboratories Inc. ®** D11/0026311

AE-001A

