

SPECIFICATION FOR APPROVAL

REF :

PAGE: 1

PROD. NAME	SMD POWER INDUCTOR	ABC'S DWG NO.	ESR1006□□□□L□-□□□
		ABC'S ITEM NO.	

I . CONFIGURATION & DIMENSIONS :

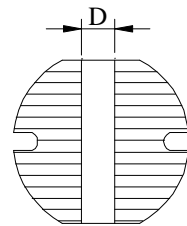
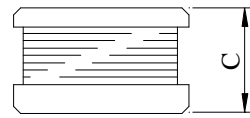
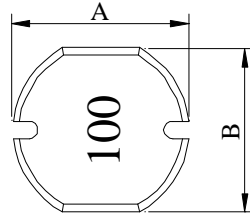

- A : 10.0±0.4 m/m
- B : 9.0±0.4 m/m
- C : 5.4±0.4 m/m
- D : 2.1 ref. m/m
- G : 2.5 ref. m/m
- H : 9.5 ref. m/m
- I : 10.0 ref. m/m

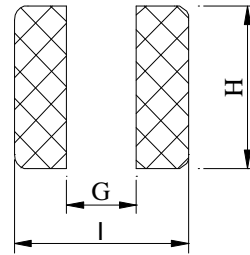

(PCB Pattern)

II . SCHEMATIC DIAGRAM :

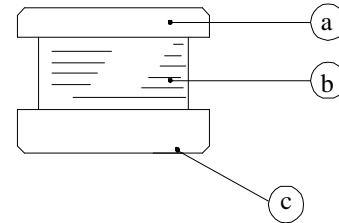

III . MATERIALS :

- a . Core : Ferrite DR core
- b . Wire : Enamelled copper wire (Class F & H)
- c . Terminal : Ag/Ni/Sn
- d . Remark : Products comply with RoHS' requirements

Peak Temp : 245±5°C
Max time above 200°C : 60sec max.

IV . GENERAL SPECIFICATION :

- a . Storage temp. : -40°C ----+125°C
- b . Operating temp. : -40°C ----+105°C
- c . Resistance to solder heat : 245±5°C.10 secs.

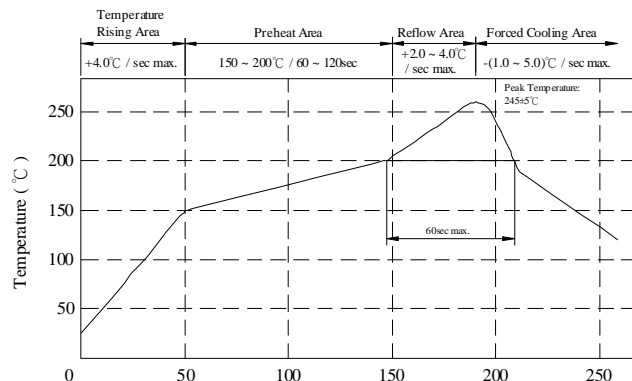

SPECIFICATION FOR APPROVAL

REF :

PAGE: 2

PROD. NAME	SMD POWER INDUCTOR	ABC'S DWG NO.	ESR1006□□□□L□-□□□
		ABC'S ITEM NO.	

V . ELECTRICAL CHARACTERISITCS :

DWG No.	Inductance (μ H)	RDC ($m\Omega$)		Rated Current (A)	SRF (MHz) ref.
		typ.	max.		
ESR1006100ML□-□□□	10 \pm 20%	34.2	60	2.60	25.0
ESR1006120ML□-□□□	12 \pm 20%	36.9	70	2.45	23.0
ESR1006150ML□-□□□	15 \pm 20%	43.6	80	2.30	19.8
ESR1006180ML□-□□□	18 \pm 20%	60.7	90	2.15	19.3
ESR1006220ML□-□□□	22 \pm 20%	68.3	100	2.00	16.0
ESR1006270ML□-□□□	27 \pm 20%	87.6	110	1.80	13.3
ESR1006330ML□-□□□	33 \pm 20%	96.9	120	1.50	12.1
ESR1006390ML□-□□□	39 \pm 20%	111.0	140	1.40	12.0
ESR1006470KL□-□□□	47 \pm 10%	126.0	170	1.30	11.0
ESR1006560KL□-□□□	56 \pm 10%	141.0	190	1.20	10.2
ESR1006680KL□-□□□	68 \pm 10%	176.0	220	1.10	9.4
ESR1006820KL□-□□□	82 \pm 10%	201.0	250	1.00	8.8
ESR1006101KL□-□□□	100 \pm 10%	262.0	350	0.97	7.3
ESR1006121KL□-□□□	120 \pm 10%	301.0	400	0.90	6.6
ESR1006151KL□-□□□	150 \pm 10%	350.0	470	0.80	6.6
ESR1006181KL□-□□□	180 \pm 10%	457.0	630	0.75	6.1
ESR1006221KL□-□□□	220 \pm 10%	524.0	730	0.70	5.3
ESR1006271KL□-□□□	270 \pm 10%	711.0	970	0.60	4.3
ESR1006331KL□-□□□	330 \pm 10%	814.0	1150	0.55	4.3
ESR1006391KL□-□□□	390 \pm 10%	923.0	1300	0.50	3.3
ESR1006471KL□-□□□	470 \pm 10%	1056.0	1480	0.45	3.3
ESR1006561KL□-□□□	560 \pm 10%	1359.0	1900	0.40	3.3
ESR1006681KL□-□□□	680 \pm 10%	1559.0	2250	0.30	2.8
ESR1006821KL□-□□□	820 \pm 10%	1805.0	2550	0.25	2.2

- 1). □ : Packaging information... A : Bulk B : Taping Reel
- 2). "-□□□":Reference code
- 3). Inductance test condition :10uH~82uH at 1MHz/1V
100uH~820uH at 1KHz/1V
- 4). Rated current: The DC current at which the inductance decreases to 90% of it's initial value or when $\Delta t=40^{\circ}C$, whichever is lower($T_a=20^{\circ}C$)

SPECIFICATION FOR APPROVAL

REF :

PAGE: 3

PROD. NAME	SMD POWER INDUCTOR	ABC'S DWG NO.	ESR1006□□□□L□-□□□
		ABC'S ITEM NO.	

VI . INDUCTANCE VS. DC CURRENT CURVE :

(1) Configuration

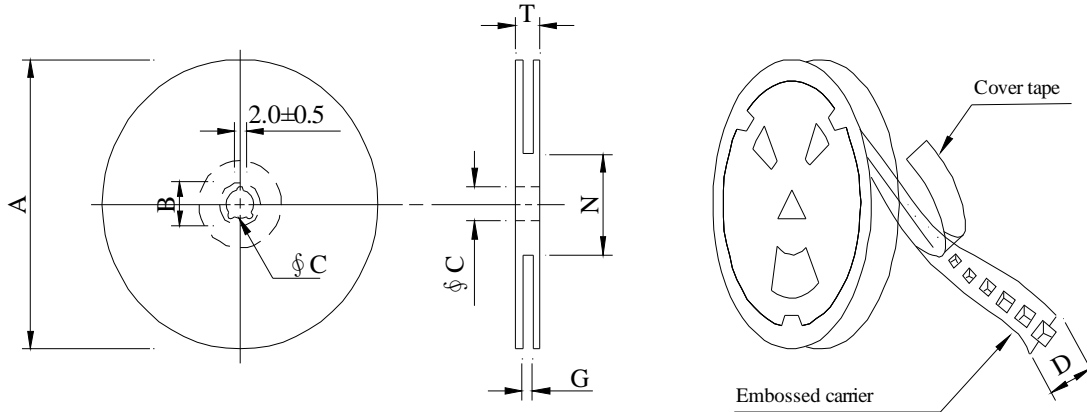

※Carrier tape width : D

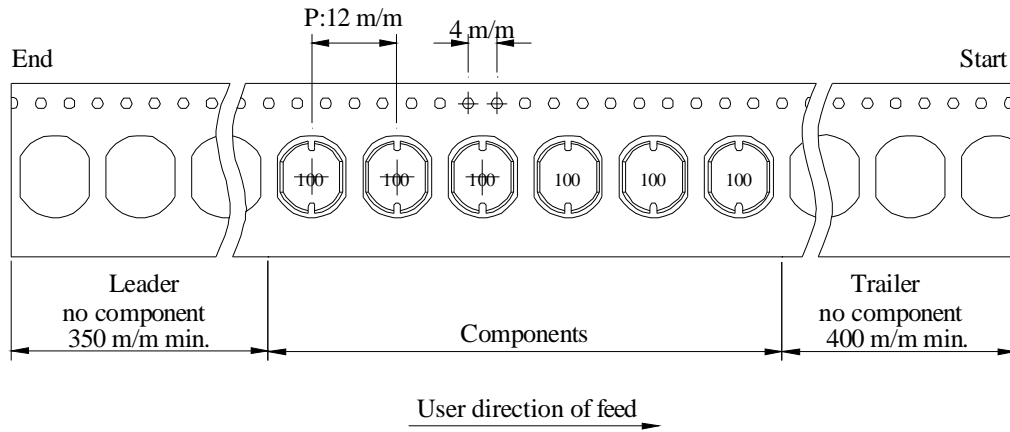

(2) Dimensions

Unit:m/m

Style	A	B	C	D	G	N	T
13 - 24	330	21±0.8	13±0.5	24	26 ⁺⁰	50 ⁻⁰	30.4

(3) Q'TY & G.W. Per package

Series	Inner : Reel			Outer : Carton		
	Q'TY (pcs)	G.W. (gw)	Style	Q'TY (pcs)	G.W. (Kg)	Size (cm)
ESR1006	800	1,800	13 - 24	3,200	9.5	40 x 40 x 24

AR-001A

SPECIFICATION FOR APPROVAL

REF :

PAGE: 4

PROD. NAME	SMD POWER INDUCTOR	ABC'S DWG NO.	ESR1006□□□□L□-□□□
		ABC'S ITEM NO.	

VII . PACKAGING INFORMATION :

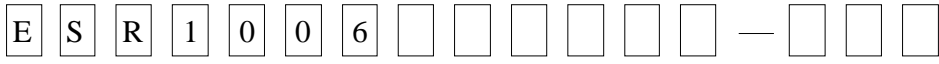

Appendix code 1 : Product Classification

- L : Lead Free Standard products comply with RoHS' requirements
- 1 ~ 9 : Lead Free Special products comply with RoHS' requirements

Appendix code 2 : Package Information

Code	Inner package	Inner package Q'TY	Remark
A	T.B.D.	T.B.D.	
B	T / R (Reel package)	800 pcs	

SPECIFICATION FOR APPROVAL

REF :

PAGE: 5

PROD. NAME	SMD POWER INDUCTOR	ABC'S DWG NO.	ESR1006□□□□L□-□□□
		ABC'S ITEM NO.	

VII . DWGING NUMBER EXPRESSION :

Test item	Specification	Test condition						
Solderability	More than 95% of the terminal electrode shall be covered With fresh solder.	Preheat : 155°C / 4 hours. Solder : Sn96.5 / Ag3 / Cu0.5 or equivalent Solder temp. : 235±5°C Flux : Rosin Dip time : 5±0.5 seconds						
Thermal shock test (Temp. cycle)	Electrical oharacteristics shall not change more than ±20%	<table style="width: 100%; border: none;"> <tr> <td style="border: none;">Room temp. 15 minutes</td> <td style="border: none; text-align: center;">→</td> <td style="border: none; text-align: center;">-40 °C 30 minutes</td> </tr> <tr> <td style="border: none;">Room temp. 15 minutes</td> <td style="border: none; text-align: center;">→</td> <td style="border: none; text-align: center;">+105 °C 30 minutes</td> </tr> </table> <p>Total : 50 cycles</p>	Room temp. 15 minutes	→	-40 °C 30 minutes	Room temp. 15 minutes	→	+105 °C 30 minutes
Room temp. 15 minutes	→	-40 °C 30 minutes						
Room temp. 15 minutes	→	+105 °C 30 minutes						
Humidity Test		Temperature : 40±2°C Humidity : 90±5% Time : 1000 hours						
High temp. Resistance test		Temperature : 105±5°C Applied current : Per spec. Time : 96 hours						

AR-001A



SPECIFICATION FOR APPROVAL

REF :

PAGE: 7

PROD. NAME	SMD POWER INDUCTOR	ABC'S DWG NO.	ESR1006□□□□L□-□□□
		ABC'S ITEM NO.	

OBMW2 October 06, 2005

Magnet Wire-Component

ELEKTRISOLA (MALAYSLA) SDN BHD E143312

JALAN DAMAI SATU JANDA BAIK 28750 BENTONG, PAHANG

DARUL MAKMUR MALAYSIA

Mtl Dsg	Mark Dsg	Coating Type		ANSI Typ	Temp Class
		BC	OC		
Estersol 180	E180	Polyesterimide (solderable)	—	MW-77	180
Amldester 200	A200	Polyesterimide	—	MW-74	200
Polysol-N 155	PN155	Polyurethane	Nylon	MW-80, MW-28	155, 130
Polysol 155	P155, G155	Polyurethane	—	MW-79, MW-75	155, 130
Polysol 155g	Pg155	Polyurethane	—	MW-75	130
Polysol 155p	Pp155,Gp155	Polyurethane	—	MW-79	155
Polysol 160	P160	Polyurethane	—	MW-79	155
Polysol 180	P180,G180	Polyurethane	—	MW-82, MW-79	180, 155
Polysol 170	P170 or G170	Polyurethane	—	MW-79	155
Polysol-N 180	PN180	Polyurethane	Nylon	MW-83	180
Polysol P155p	P155p	Polyurethane	—	MW-79	155

Marking : Company name, material designation or marked designation and factory identification on package ok reel

See General Information preceding These Recognitions

For use only in equipment where the acceptability of the combination is determined by Underwriters Laboratories Inc.

AR-001A

