



CYPRESS

CY3900I / CY3950I

Delta39K™/Ultra37000™ ISR™ Programming Kits

Features

- Supports Cypress's Ultra37000™, Ultra37000V™, Delta39K™, and PSI™ families of products
- STAPL (Chain Dependent and Chain Independent) programming language support
- SVF programming language support
- Standard JTAG programming interface
- Multi-device programming
- Easy to use Windows XP™, Windows 2000™, Windows ME™, Windows 98™, and Windows NT™-compatible interface
- Eliminates programming insertion to improve manufacturing efficiency
- For programming in the lab, on manufacturing floor, or at remote sites
- ATE support via STAPL on industry leading ATE platforms

CY3900I Kit Contents

- C3ISR™ Programming Cable^[3] for use with Ultra37000, Delta39K, and PSI CPLD families
- Delta39K/Ultra37000 prototype board^[1]
- ISR application notes

CY3950I Kit Contents

- USBISR Programming Cable^[3] for use with Ultra37000, Delta39K, and PSI CPLD families
- Delta39K/Ultra37000 prototype board^[1]
- ISR application notes

Functional Description

The Delta39K/Ultra37000 ISR Programming Kit enables users to program Ultra37000, Ultra37000V, Delta39K, and PSI CPLDs on board with our ISR Programming Software, the C3ISR or USBISR Programming Cable, and a personal computer. The C3ISR Programming Cable connects to the parallel port of a PC and the USBISR Programming Cable^[3] connects to a USB 1.1/USB 2.0 port of a PC into a standard 10-pin male connector mounted on the user's board. The ISR software provides an easy-to-use Graphical User Interface that accepts JEDEC or hex files as input. The JEDEC/.hex files are used to compose platform independent STAPL/SVF files. STAPL/SVF files contain all the information needed to program the device. The ISR software is used to define how many devices are in the daisy chain and what operation is to be done on each Cypress device. The same chain can be used with other JTAG-compliant devices.

The ISR User's Guide describes the operation of the ISR software. The application notes included with the kit describe all system design considerations for programming with this Programming Kit.

10-pin Programming Connector

The view looking into the end of the 10-pin ISR cable is shown below.^[2]

Pin 1				
GND	JTAG _{EN}	ISR*	V _{CC}	TDO
TMS	TCK	TDI	N/C	GND

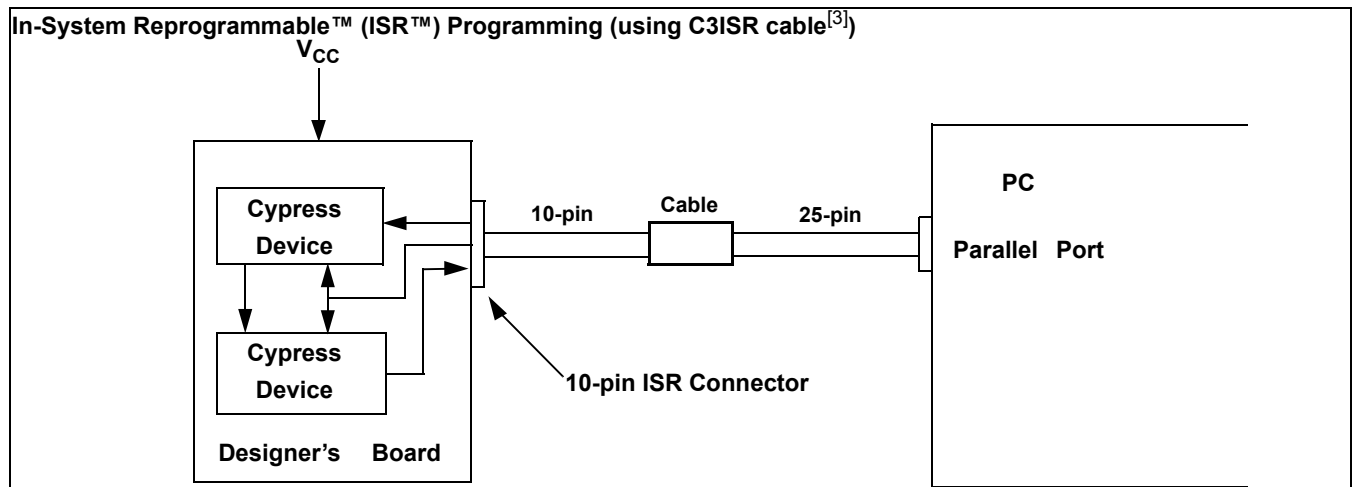

Notes:

1. Cypress reserves the right to substitute prototype boards based on product availability.
2. Refer to the CD-ROM ISR User's Guide documentation for detailed information on ISR programming and electrical specification requirements.
3. The C3ISR Programming Cable is available in the CY3900I Programming Kit and the USBISR Programming Cable is available in the CY3950I Programming Kit.

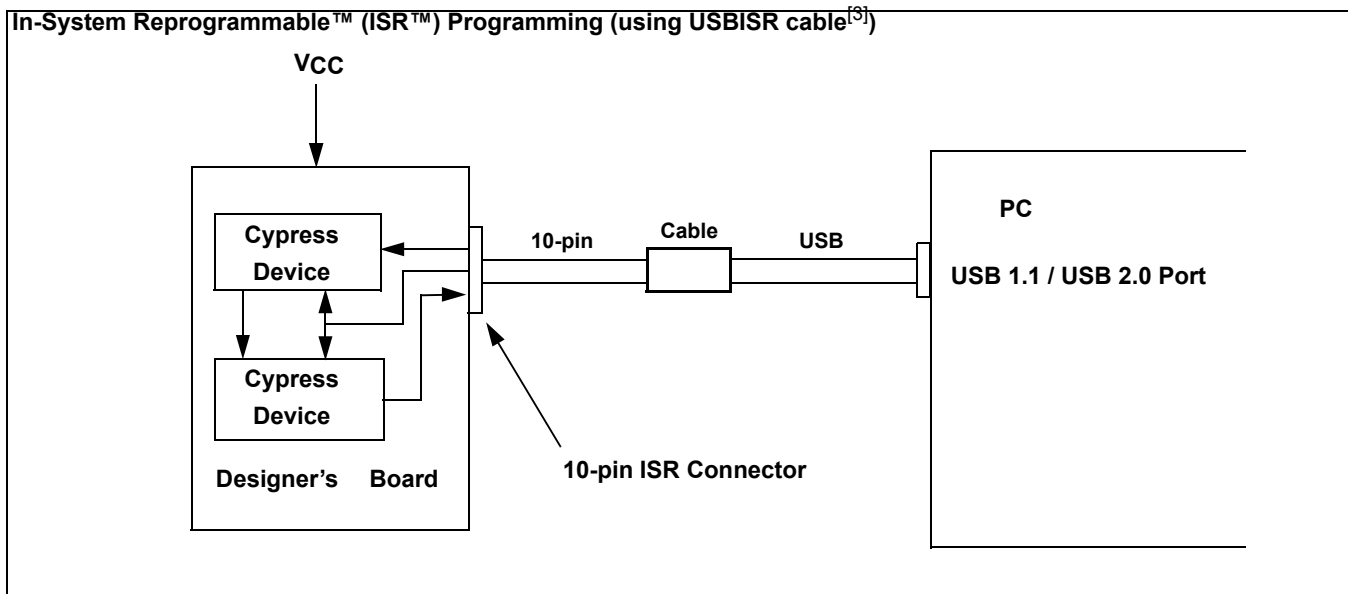
Table 1. C3ISR / USBISR Cable Pin Descriptions

Pin	Type	Description
JTAGen	OUTPUT	In System Reprogramming JTAG Enable (active HIGH).
ISR*	OUTPUT	In System Reprogramming Enable Indicator (active LOW).
VCC	INPUT	+5V and +3.3V Supply Voltage provided from the target system to the cable.
TDO	INPUT	Test Data Output Receiver. The TDO output pin of the last device in the ISR chain of the system is connected to this input pin.
TMS	OUTPUT	Test Mode Control. This is the mode select control input for the TAP controller state machine contained in the ISR interface.
TCK	OUTPUT	Test Clock. ISR interface clock.
TDI	OUTPUT	Test Data Input Driver. This output pin is connected to the TDI input of the first device in the ISR chain.
NC	NC	No Connect.
GND	—	Zero volt common ground for PC and target system.

Table 1 describes the function of each of these pins on the C3ISR and USBISR Programming Cables. An OUTPUT is provided by the PC and an INPUT is provided by the target system.

The dimensions of the male connector required for the C3ISR and the USBISR Programming Cables are given below.

Male Connector

2 x 5 = 2 rows, 5 pins per row

Measuring from center of the pins, each pin is 0.1" from the others.

Pin length is 0.23".

Pin cross-section is 0.025" x 0.025".

Note:

4. See Figure 1 for the basic layout.

Part Number

Digi-Key® S2012-05-ND (straight-pin connector).

Digi-Key S2112-05-ND (right-angle connector).

To facilitate easy and quick prototyping of designs, a Delta39K/Ultra37000 Prototype Board^[4] has been included in the CY3900i Delta39/Ultra37000 ISR Programming Kit. The prototype board comes with a CY37256VP160 device and a CY39100V208 device already premounted and header strips that facilitate signal testing. Detailed information on the board layout and proper usage may be found in the Cypress application note, *Using the Delta39K ISR Prototype Board*.

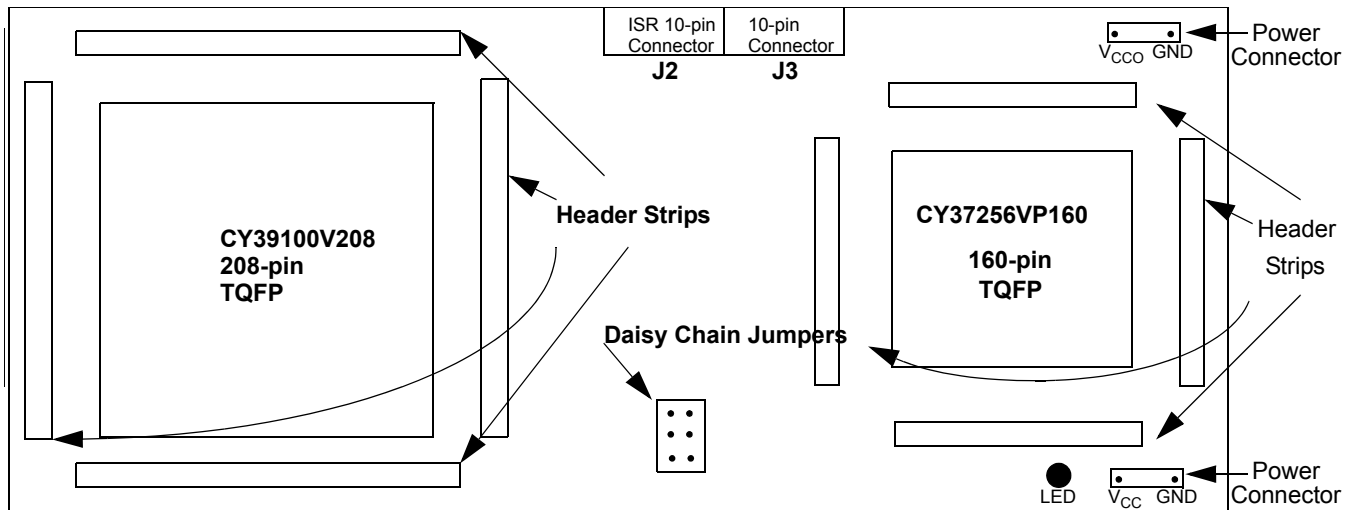

Figure 1. Delta39K/Ultra37000 Prototype Board

PC System Requirements

- IBM PC or compatible running Windows 98, Windows 98 Second Edition, Windows ME, Windows NT 4.0 Service Pack 5 or later or Windows 2000 Service Pack 1 or later and Windows XP.
- One free parallel, USB 1.1 or 2.0 (recommended) port
- A minimum of 32 MB of RAM.
- Approximately 30 MB of free hard disk space.

Ordering Information

Product Code	Description
CY3950I	Delta39K/Ultra37000 ISR Programming Kit (with USBISR Programming Cable)
CY3900I	Delta39K/Ultra37000 ISR Programming Kit (with C3ISR parallel Programming Cable)

Windows 98, Windows ME, Windows 2000, Windows NT and Windows XP are trademarks of Microsoft Corporation. Digi-Key is a registered trademark of Digi-Key Corporation. ISR, C3ISR, USBISR, Ultra37000, Delta39K, and PSI are trademarks of Cypress Semiconductor. All products and company names mentioned in this document may be the trademarks of their respective holders.

Document History Page

Document Title: Delta39K™/Ultra37000™ ISR™ Programming Kit				
Document Number: 38-03009				
REV.	ECN NO.	Issue Date	Orig. of Change	Description of Change
**	108980	08/07/01	HOW	New Data Sheet
*A	111228	01/23/02	CNH	Removed references to Windows 95
*B	127867	08/18/03	FSG	Removed Quantum38K from all pages
*C	130222	10/09/03	FSG	Added CY3950I kit
*D	325995	See ECN	PCX	Updated 10-pin Connector Figure
*E	391577	See ECN	PCX	Deleted ISR Software 4.0 from Kit Contents