

**DESCRIPTION**

The J54 sprinkler switches are designed to activate upon alarms in either wet or dry pipe sprinkler systems. Model 8295 is UL Listed for supervisory service as well as being UL Listed and FM approved as a waterflow alarm switch to sound local or central station alarms.

Models 8300 and 8305, primarily used as supervisory and/or control switches for sprinkler systems, are UL Listed and designed to receive approval upon submission of total system to Factory Mutual.



**FEATURES**

- **Model 8295 FM Approved for 20,000 Cycle Life Requirement at 125 PSI Testing, Qualified in FM Leak Test to 500 PSI**
- **Model 8295 UL Tested for 100,000 Cycles at all E/R Loads and Normal Pressure.**
- **Models 8300 and 8305 Qualified in UL Leak Test Minimum Requirement of 350 PSI Without Leakage or Rupture**
- **Calibration Accuracy Maintained up to 300 PSI**
- **Buna-N Dacron-backed Diaphragm Sensor for Fast Response and Repeatability ±1% of range**

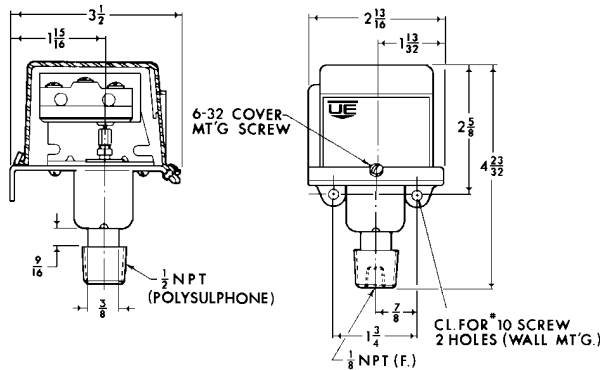

**ORDERING INFORMATION/SPECIFICATIONS**

Part No.	Model	Adjustable Range	On-Off Differential
117-2110A	J54/8295	2 to 15 PSI	0.7 to 1.7 PSI
117-1120A	J54/8300	10 to 100 PSI	1.0 to 2.5 PSI
117-1130A	J54/8305	20 to 200 PSI	1.5 to 4.0 PSI

**Pressure Connection:** 1/2" NPT male polysulphone\*  
**Contact Type:** SPDT  
**Contact Ratings:** 15 amps @ 125/150 VAC  
 10 amps @ 12 VDC  
 1/4 HP @ 125 VAC  
 125 VA Pilot Duty at 125/150 VAC  
 \*1/8" and 1/4" NPT male aluminum pressure connections available

Specifications are provided for information only and are believed to be accurate. However, no responsibility is assumed by Fire Control Instruments, Inc. for their use. © 1997 All Rights Reserved