

AS85049/94 Mounting Flange, Full Perimeter

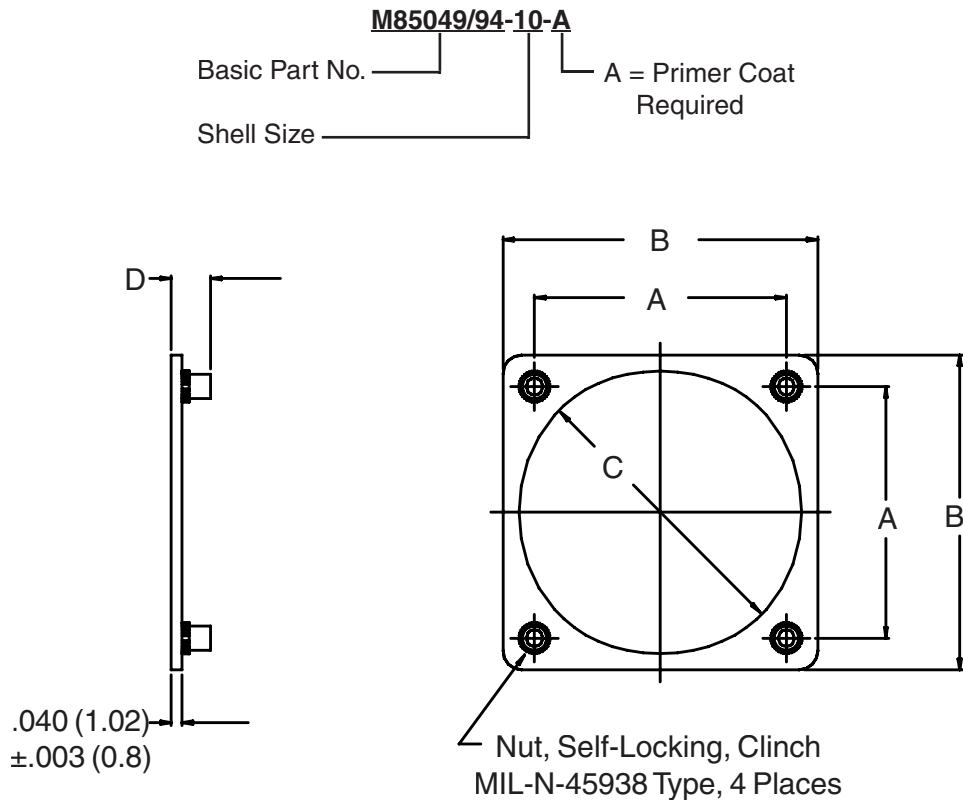

TABLE I

Shell Size	Thread UNJC-3B	A		B		C		D	
		±.015	(.38)	Max		±.015	(.4)		
8	4-40	.594	(15.1)	.980	(24.9)	.570	(14.5)	.106	(.166)
10	4-40	.719	(18.3)	1.034	(26.3)	.720	(18.3)	.106	(.166)
12	4-40	.812	(20.6)	1.119	(28.4)	.855	(21.7)	.106	(.166)
14	4-40	.906	(23.0)	1.213	(30.8)	.984	(25.0)	.106	(.166)
16	4-40	.969	(24.6)	1.295	(32.9)	1.094	(27.8)	.106	(.166)
18	4-40	1.062	(27.0)	1.421	(36.1)	1.220	(31.0)	.106	(.166)
20	4-40	1.156	(29.4)	1.550	(39.4)	1.345	(34.2)	.106	(.166)
22	4-40	1.250	(31.8)	1.680	(42.7)	1.478	(37.5)	.106	(.166)
24	6-32	1.375	(34.9)	1.800	(45.7)	1.595	(40.5)	.123	(.183)
25	6-32	1.500	(38.1)	1.910	(48.5)	1.658	(42.1)	.123	(.183)

Application Notes:

1. For complete dimensions see applicable Military Specification.
2. Metric dimensions (mm) are indicated in parentheses.

