

Dual Port VDSL2 Line Driver

ISL1539A

The ISL1539A provides 4 internal wideband op amps intended to be used as two pairs of differential line drivers. The ISL1539A's high bandwidth, 240MHz, and ultra low distortion, -89dBc @ 1MHz, 2V_{p-p}, support the demanding MTPR requirements of emerging VDSL2 line driver designs. Less demanding requirements can be met at very low quiescent powers using the supply current adjustment features.

Each of the 4 internal op amps is a wideband current feedback amplifier offering very high slew rate intrinsic to that design using low quiescent current levels. Each of the two pair of amplifiers (ports) can also be power optimized to the application using two external quiescent control logic pins. Full power is nominally 27.2mA/port with options of medium power cutback to 23mA/port, a low power condition at 13.5mA/port, and an off state at <0.5mA/port. Added quiescent power flexibility is provided through an external I_{ADJ} pin. Grounding the pin gives the nominal currents listed above while inserting a resistor from this pin to ground can be used to scale each of the settings downward.

High power push/pull line driver applications as illustrated in the example below are best supported using a low headroom, high output current device. On ±12V supplies, the ISL1539A offers a 1.1V headroom with >360mA peak output current. Driving differentially this gives >41.8V_{p-p} swing to as low as 58Ω differential load. High SFDR operation is also supported for supplies as low as ±7.5V. Intended to be used as differential pairs, this two port device includes special circuitry to minimize common mode loop peaking while also reducing the common mode output noise spectrum. That circuitry links the two sides of each port, precluding their application as individual amplifiers.

Features

- 360mA Output Drive Capability
- 41.8V_{p-p} Differential Output Drive into 100Ω
- -89dBc THD @ 1MHz 2V_{p-p}
- -65dBc MTPR (VDSL 8b Profile)
- High Slew Rate of 3000V/μs Differential
- Bandwidth (240MHz @ A_{V-DIFF} = 10)
- Supply Current Control Pins
- Port Separation
 - 78dB @ 500kHz
 - 70dB @ 1MHz
 - 60dB @ 4MHz
- Pb-Free (RoHS Compliant)

Applications* (see page 21)

- 8MHz and 17MHz VDSL2 Profiles
- ADSL2+

Related Literature (see Device Info page)

- AN1325 "Choosing and Using Bypass Capacitors"
- TB426 "Characterization of the Output Protection Circuitry of the EL1528 DSL Driver for Lightning Surges"

TABLE 1. ALTERNATE SOLUTIONS

PART #	NOMINAL ±V _{CC} (V)	BANDWIDTH (MHz)	APPLICATIONS
ISL1557	±6	200	VDSL
ISL1534	±12	40	ADSL2+
ISL1536	±12	50	ADSL2+

Typical Application

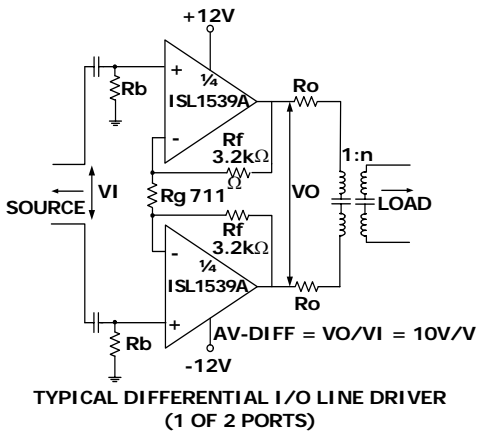

4MHz Harmonic Distortion

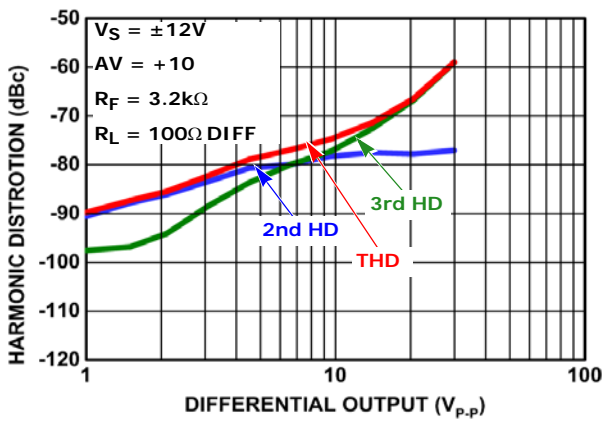

For additional products, see www.intersil.com/product_tree

Intersil products are manufactured, assembled and tested utilizing ISO9000 quality systems as noted in the quality certifications found at www.intersil.com/design/quality

Intersil products are sold by description only. Intersil Corporation reserves the right to make changes in circuit design, software and/or specifications at any time without notice. Accordingly, the reader is cautioned to verify that data sheets are current before placing orders. Information furnished by Intersil is believed to be accurate and reliable. However, no responsibility is assumed by Intersil or its subsidiaries for its use; nor for any infringements of patents or other rights of third parties which may result from its use. No license is granted by implication or otherwise under any patent or patent rights of Intersil or its subsidiaries.

For information regarding Intersil Corporation and its products, see www.intersil.com