

## GLASS PASSIVATED BRIDGE RECTIFIERS

REVERSE VOLTAGE - **50 to 1000**Volts  
FORWARD CURRENT - **2.0** Amperes

### FEATURES

- Rating to 1000V PRV
- Ideal for printed circuit board
- Low forward voltage drop, high current capability
- Reliable low cost construction utilizing molded plastic technique results in inexpensive product
- The plastic material has UL flammability classification 94V-0

### MECHANICAL DATA

- Polarity: As marked on Body
- Weight: 0.02 ounces, 0.38 grams
- Mounting position: Any

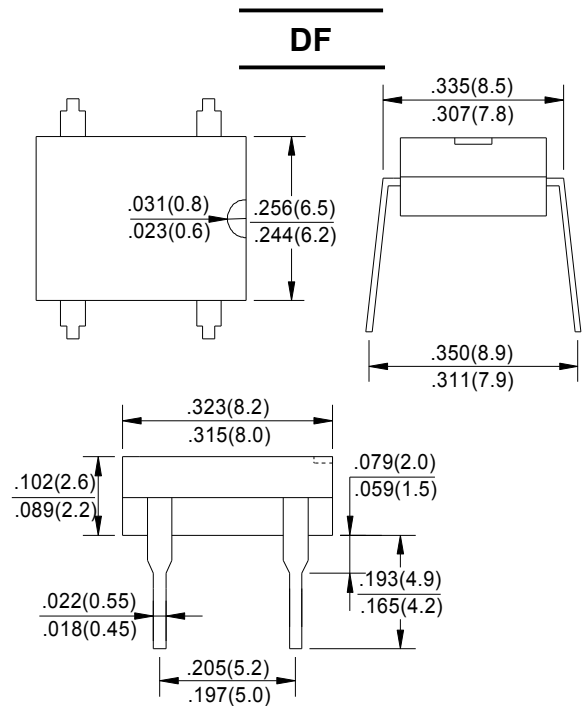

Dimensions in inches and (millimeters)

## MAXIMUM RATINGS AND ELECTRICAL CHARACTERISTICS

Rating at 25°C ambient temperature unless otherwise specified.

Single phase, half wave, 60Hz, resistive or inductive load.

For capacitive load, derate current by 20%

CHARACTERISTICS	SYMBOL	DF 2005	DF 201	DF 202	DF 204	DF 206	DF 208	DF 210	UNIT
Maximum Recurrent Peak Reverse Voltage	V <sub>RRM</sub>	50	100	200	400	600	800	1000	V
Maximum RMS Voltage	V <sub>RMS</sub>	35	70	140	280	420	560	700	V
Maximum DC Blocking Voltage	V <sub>DC</sub>	50	100	200	400	600	800	1000	V
Maximum Average Forward Rectified Current @T <sub>A</sub> =40°C	I <sub>(AV)</sub>	2.0							A
Peak Forward Surge Current 8.3ms Single Half Sine-Wave Super Imposed on Rated Load (JEDEC .Method)	I <sub>FSM</sub>	60							A
Maximum Forward Voltage at 2.0A DC	V <sub>F</sub>	1.1							V
Maximum DC Reverse Current @T <sub>J</sub> =25°C at Rated DC Blocking Voltage @T <sub>J</sub> =125°C	I <sub>R</sub>	10 500							μA
I <sup>2</sup> t Rating for Fusing (t<8.3ms)	I <sup>2</sup> t	10.4							A <sup>2</sup> s
Typical Junction capacitance Per Element(Note1)	C <sub>J</sub>	25							pF
Typical Thermal Resistance (Note2)	R <sub>θJA</sub>	40							°C/W
Operating Temperature Range	T <sub>J</sub>	-55 to +150							°C
Storage Temperature Range	T <sub>STG</sub>	-55 to +150							°C

Note:1.Measured at 1.0MHz and applied reverse voltage of 4.0V DC

2.Thermal resistance from junction to ambient mounted on P.C.B  
with 0.5\*0.5"(13\*13mm) copper pads.



FIG.1-DERATING CURVE FOR  
 OUTPUT RECTIFIED CURRENT

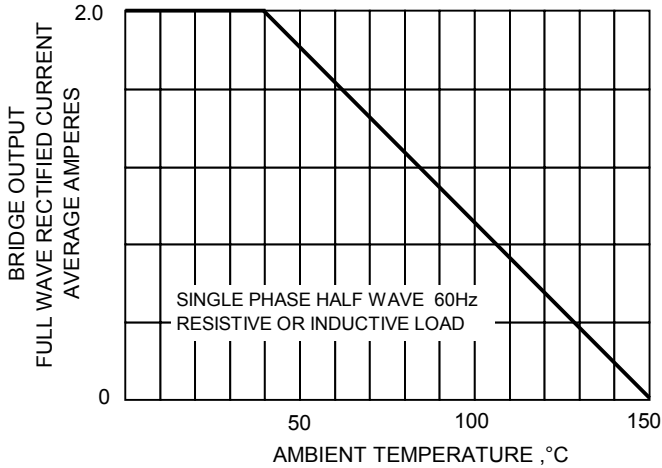

FIG.2-MAXIMUM NON-REPETITIVE PEAK  
 FORWARD SURGE CURRENT

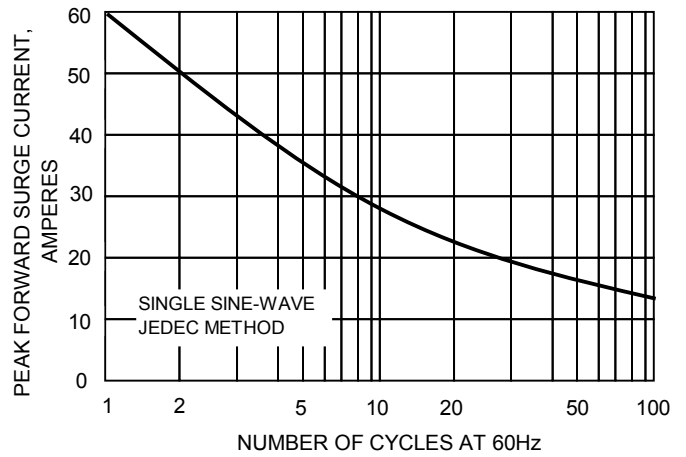

FIG.3-TYPICAL JUNCTION CAPACITANCE

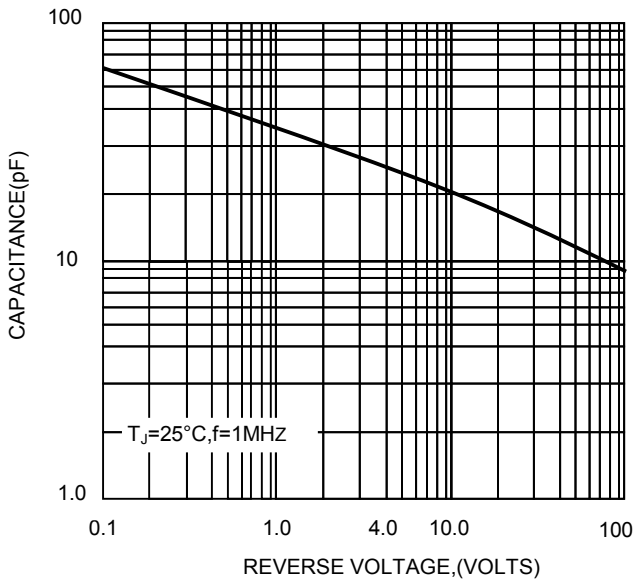

FIG.4-TYPICAL FORWARD CHARACTERISTICS

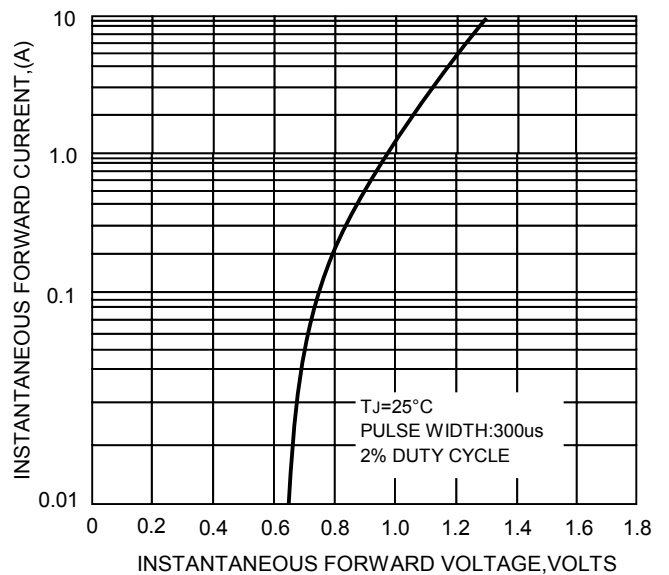

FIG.5-TYPICAL REVERSE CHARACTERISTICS

