

SPC-03-LR-xx

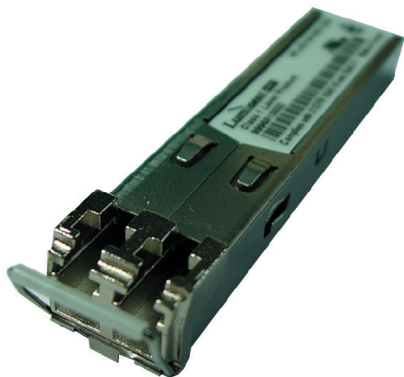

Features

- Single 3.3V supply
- 29dB Minimum Link Budget
- DFB Laser
- 1470nm to 1610nm CWDM Wavelengths
- SFP MSA SFF-8074i Compatible
- Commercial and Industrial Temperature
- Telcordia GR-253 OC-3/ITU-T G.957 STM-1 Compliant
- Digital Diagnostic SFF-8472 Compliant
- Telcordia GR-468 Compliant
- RoHS-5/6 Compliant Product (lead exemption)

General Operation

Parameter	Symbol	Min.	Typical	Max.	Unit
Supply Voltage	V_{CC}	3.135	3.3	3.465	V
Total Current (-40 to -5 °C) ^a	I_{CC}	-	-	500	mA
Total Current (-5 to 85 °C)	I_{CC}	-	-	300	mA
Total Current Each Supply Pin	I_{CC}	-	-	300	mA
Power Supply Noise Rejection	PSR	100	-	-	mV _{p-p}
Operating Case Temperature (-CXX)	T_{Op}	-5	-	70	°C
Operating Case Temperature (-TXX)	T_{Op}	-40	-	85	°C
Storage Temperature	T_{St}	-40	-	85	°C
Data Rate OC-3/STM-1	DR	-	155	-	Mbps

a) Deviation from the SFP MSA

Transmitter Specifications (Optical)

Parameter	Symbol	Min	Typical	Max	Unit
Optical Power	P_{Op}	-5	-	0	dBm
Average Launch Power (Tx:Off)	P_{Off}	-	-	-30	dBm
Extinction Ratio	ER	10	-	-	dB
Eye Mask		-	-	-	SONET/SDH compliant
Optical Jitter Generation	J_{gen}	-	-	0.002	UI
Optical Rise Time ^b	t_r	-	-	1000	ps
Optical Fall Time ^b	t_f	-	-	1000	ps
Wavelength	λ	1xx1-6.5	1xx1	1xx1+6.5	nm
Spectral Width (20dB)	$\Delta\lambda$	-	-	1	nm
Side Mode Suppression Ratio	SMSR	30	-	-	dB
Dispersion Penalty (120km)		-	0.5	2	dB
Relative Intensity Noise	RIN	-	-	-120	dB/Hz
Reflection Tolerance	rp	-24	-	-	dB

b) 20%-80% values

SPC-03-LR-xx

Transmitter Specifications (Electrical)

Parameter	Symbol	Min	Typical	Max	Unit
Input Differential Impedance	R_{in}	80	100	120	Ω
PECL Single-Ended Data Input Swing	$V_{in,p-p}$	250	-	1200	mV
TxFault_Fault	V_{fault}	2	-	V_{cc}	V
TxFault_Normal	V_{normal}	V_{ee}	-	$V_{ee}+0.5$	V
TxDisable_Disable	V_d	2	-	V_{cc}	V
TxDisable_Enable	V_{en}	V_{ee}	-	$V_{ee}+0.8$	V

Receiver Specifications (Optical)

Parameter	Symbol	Min	Typical	Max	Unit
Receive Power Low ^c	$R_{sens,low}$	-	-36	-34	dBm
Receive Power High ^c	$R_{sens,high}$	-10	-	-	dBm
Damage Threshold For Receiver	$P_{in,damage}$	4	-	-	dBm
Wavelength ^d	λ	1260	-	1620	nm
LOS Assert		-44	-	-	dBm
LOS De-Assert		-	-	-34	dBm
LOS Hysteresis		0.5	-	-	dB

c) at 10^{-10} BER, PRBS 2²³-1

d) Operational over 1200 to 1625 nm range

Receiver Specifications (Electrical)

Parameter	Symbol	Min	Typical	Max	Unit
PECL Single-Ended Data Output Swing	$V_{out,p-p}$	185	-	800	mV
Data Output Rise Time	t_r	-	-	1000	ps
Data Output Fall Time	t_f	-	-	1000	ps

Timing and Electrical

Parameter	Symbol	Min	Typical	Max	Unit
Tx Disable Negate Time	t_{on}	-	-	5	ms
Tx Disable Assert Time	t_{off}	-	-	10	μ s
Time To Initialize, Including Reset Of Tx Fault	t_{init}	-	-	300	ms
Start-up time from <0°C	t_{start_up}	-	-	60	sec
Tx Fault Assert Time	t_{fault}	-	-	100	μ s
Tx Disable To Reset	t_{reset}	10	-	-	μ s
LOS Assert Time	t_{loss_on}	-	-	100	μ s
LOS De-Assert Time	t_{loss_off}	-	-	100	μ s
Serial ID Clock Rate	f_{serial_clock}	-	-	100	kHz
RX_LOS Voltage (High)		2	-	-	V
RX_LOS Voltage (Low)		-	-	0.8	V
LOS Output Voltage-Fault	$V_{LOS\ fault}$	2	-	V_{cc}	V
LOS Output Voltage-Normal	$V_{LOSnormal}$	V_{ee}	-	$V_{ee}+0.5$	V
MOD_DEF (0:2)-High	V_h	2	-	V_{cc}	V
MOD_DEF (0:2)-LOW	V_l	V_{ee}	-	$V_{ee}+0.5$	V

SPC-03-LR-xx

 λ Wavelength Ordering

SPC-03-ELR-xxCDA

See table below for "XX" values

Code	λ_c	Unit	Code	λ_c	Unit	Code	λ_c	Unit	Code	λ_c	Unit
47	1471	nm	49	1491	nm	51	1511	nm	53	1531	nm
55	1551	nm	57	1571	nm	59	1591	nm	61	1611	nm

Diagnostics

Parameter	Range	Accuracy	Unit	Calibration	Formula
Temperature (-CDA)	-5 to 70	± 3	$^{\circ}$ C	Internal	$T_c(C) = T_{ad}(16 \text{ bit signed twos complement})/256$
Temperature (-TDA)	-40 to 85	± 3	$^{\circ}$ C	Internal	$T_c(C) = T_{ad}(16 \text{ bit signed twos complement})/256$
Voltage	0 to V_{cc}	0.1	V	Internal	$V(\text{Volts}) = V_{ad}(16 \text{ bit unsigned integer}) * 0.1$
Bias current	0 to 120	5	mA	External	$I(\text{mA}) = I_{slope} * I_{ad}(16 \text{ bit unsigned integer}) + I_{offset}$
TX Power	-5 to 0	± 3	dBm	External	$TX_PWR(\mu W) = TX_PWR_{slope} * TX_PWR_{ad}(16 \text{ bit unsigned integer}) + TX_PWR_{offset}$
RX Power	-34 to -10	± 3	dBm	External	$RX_PWR(\mu W) = A_0 + A_1 * x + A_2 * x^2 + A_3 * x^3 + A_4 * x^4$

SPC-03-LR-xx

EEPROM Serial ID				
Name of Field	Description of Field	Address	Hex	ASCII
Vendor Name	SFP Vendor name(ASCII)	20	4C	L
		21	55	U
		22	4D	M
		23	49	I
		24	4E	N
		25	45	E
		26	4E	N
		27	54	T
		28	4F	O
		29	49	I
		30	43	C
Vendor OUI	IEEE vendor OUI code for LuminentOIC Inc.	37	00	
		38	06	
		39	B5	
Vendor P/N	Part number in ASCII, e.g. SPC-03-LR-47CDA	40	53	S
		41	50	P
		42	43	C
		43	30	0
		44	33	3
		45	4C	L
		46	52	R
		47	34	4
		48	37	7
		49	43	C
		50	44	D
51	41	A		

SPC-03-LR-xx

Pin	Function	Notes
1	V_{eeT}	
2	TX_FAULT	Open Collector
3	TX_DISABLE	Internally Pulled High
4	MOD_DEF2	Serial Data Input
5	MOD_DEF1	Serial Clock Input
6	MOD_DEF0	Internally Grounded
7	NC	Not Connected
8	LOS	Open Collector
9	V_{eeR}	RX Ground
10	V_{eeR}	RX Ground
11	V_{eeR}	RX Ground
12	RXD-	RX Data Negative
13	RXD+	RX Data Positive
14	V_{eeR}	RX GND
15	V_{ccR}	TX and RX Power ^a
16	V_{ccT}	TX and RX Power ^a
17	V_{eeT}	TX GND
18	TXD+	TX Data Positive
19	TXD-	TX Data Negative
20	V_{eeT}	TX GND

a) deviations from the SFP MSA

SPC-03-LR-xx

Outline Drawing

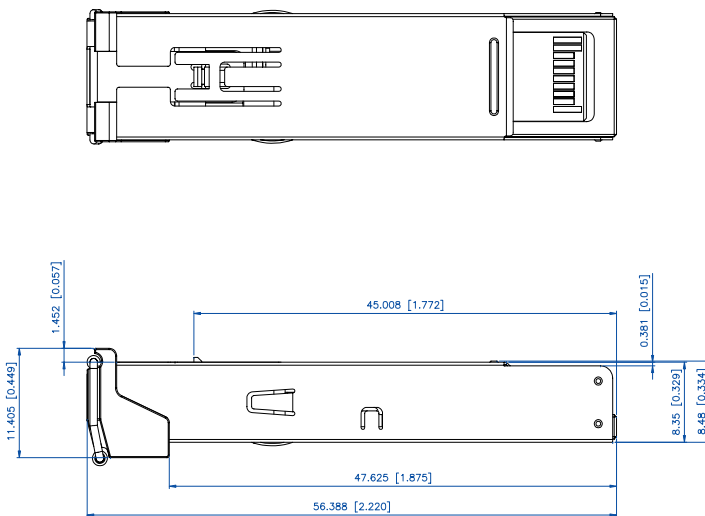
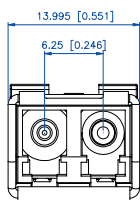

Units in mm(inch)

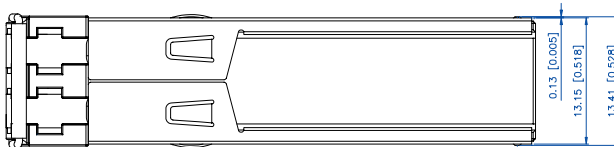

SPC-03-LR-xx

Suggested Transceiver Interface

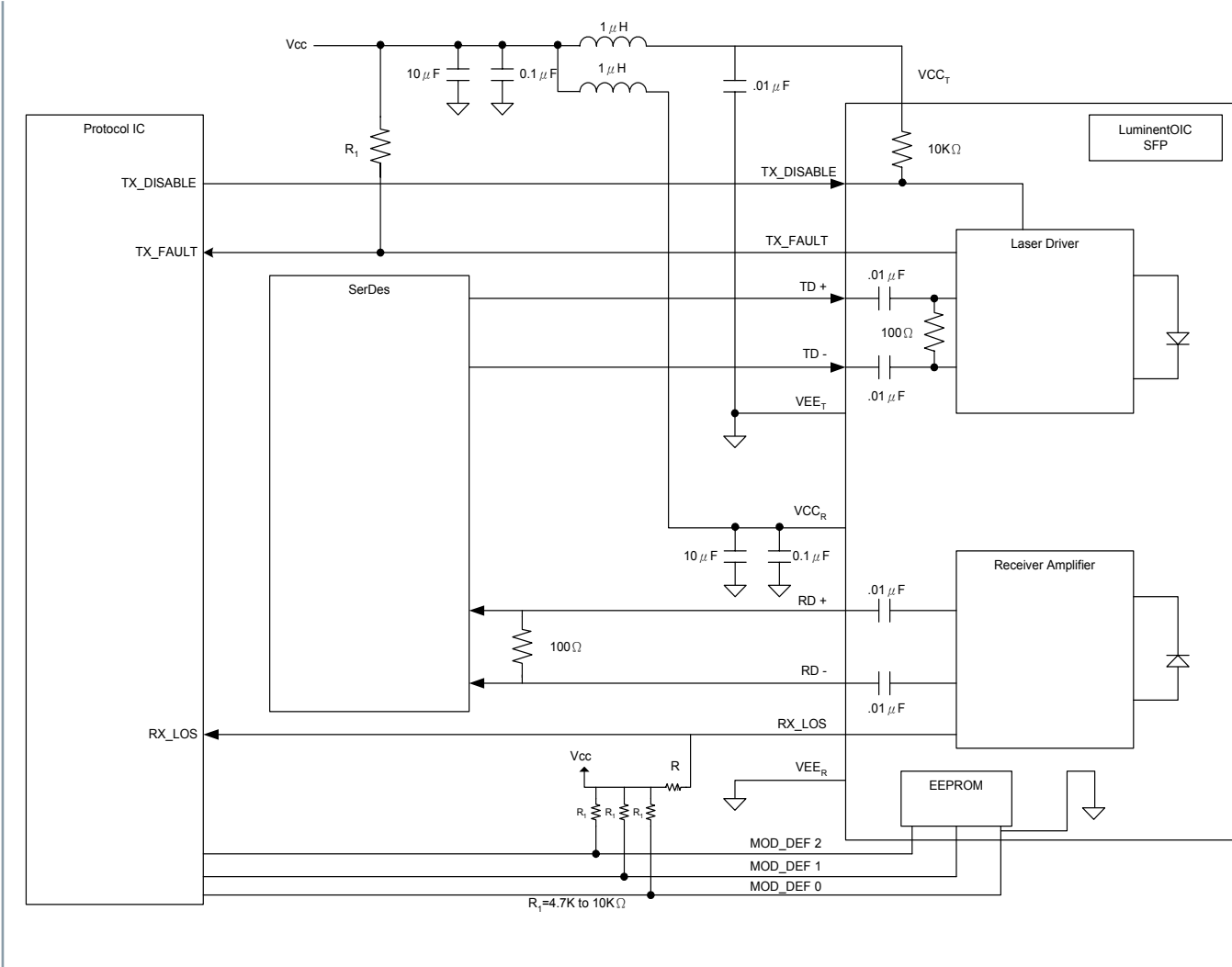

Ordering Information

Available Options:

- SPC-03-LR-xxCDA
- SPC-03-LR-xxCNA
- SPC-03-LR-xxTDA
- SPC-03-LR-xxTNA

Part Numbering Definition:

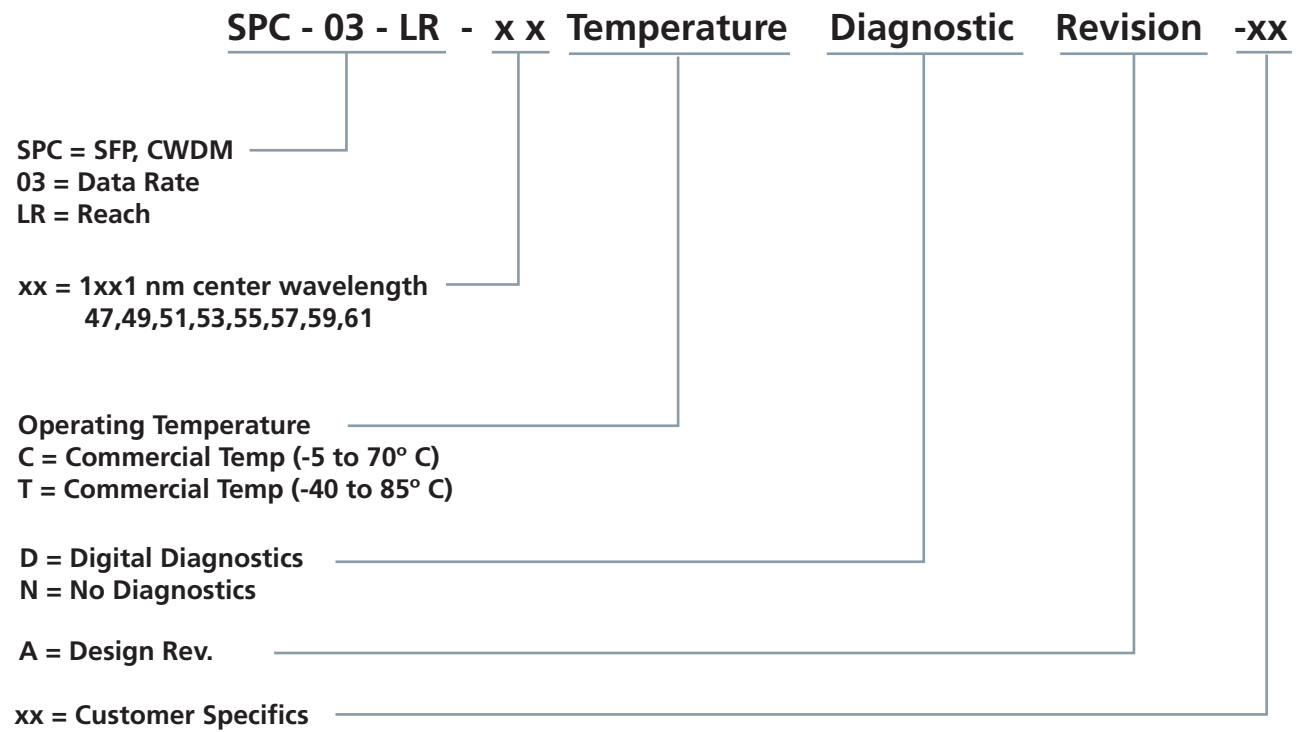

Warnings:

Handling Precautions: This device is susceptible to damage as a result of electrostatic discharge (ESD). A static free environment is highly recommended. Follow guidelines according to proper ESD procedures.

Laser Safety: Radiation emitted by laser devices can be dangerous to human eyes. Avoid eye exposure to direct or indirect radiation.

Legal Notes:**IMPORTANT NOTICE!**

All information contained in this document is subject to change without notice, at LuminentOIC's sole and absolute discretion. LuminentOIC warrants performance of its products to current specifications only in accordance with the company's standard one-year warranty; however, specifications designated as "preliminary" are given to describe components only, and LuminentOIC expressly disclaims any and all warranties for said products, including express, implied, and statutory warranties, warranties of merchantability, fitness for a particular purpose, and non-infringement of proprietary rights. Please refer to the company's Terms and Conditions of Sale for further warranty information.

LuminentOIC assumes no liability for applications assistance, customer product design, software performance, or infringement of patents, services, or intellectual property described herein. No license, either express or implied, is granted under any patent right, copyright, or intellectual property right, and LuminentOIC makes no representations or warranties that the product(s) described herein are free from patent, copyright, or intellectual property rights. Products described in this document are NOT intended for use in implantation or other life support applications where malfunction may result in injury or death to persons. LuminentOIC customers using or selling products for use in such applications do so at their own risk and agree to fully defend and indemnify LuminentOIC for any damages resulting from such use or sale.

THE INFORMATION CONTAINED IN THIS DOCUMENT IS PROVIDED ON AN "AS IS" BASIS. Customer agrees that LuminentOIC is not liable for any actual, consequential, exemplary, or other damages arising directly or indirectly from any use of the information contained in this document. Customer must contact LuminentOIC to obtain the latest version of this publication to verify, before placing any order, that the information contained herein is current.

© LuminentOIC, Inc. 2003
All rights reserved