

Custom Clock Generator for Display Systems

Features

- Custom Clock Generator for Display Systems
- 30-100MHz Wide Operating Frequency Range covering most of the pixel frequencies
- Generates a low EMI 1x Output
- 4 Spread Deviation selection options
- Supply voltage : 3.3V / 2.5V
- 6 Pin TSOT-26 package
- Commercial and Industrial Temperature range

Product Description

PCS3P7100A is a versatile spread spectrum modulator designed specifically for a wide range of clock frequencies. The device addresses the need of a low EMI clock generator for use in display systems covering

wide choice of pixel frequencies.

PCS3P7100A reduces electromagnetic interference (EMI) at the clock source, allowing system wide reduction of EMI of all clock dependent signals. PCS3P7100A allows significant system cost savings by reducing the number of circuit board layers ferrite beads, shielding that are traditionally required to pass EMI regulations.

The Supply Voltage of the Device is 3.3V/2.5V. It has two Spread Selection Pins, SS1% and SS2%. Refer to the Spread Deviation Selection Table for details. The Device is available in 6 Pin TSOT-26 Package, in Commercial and Industrial Temperature grade.

Applications

PCS3P7100A is targeted for use in Display Systems

Block Diagram

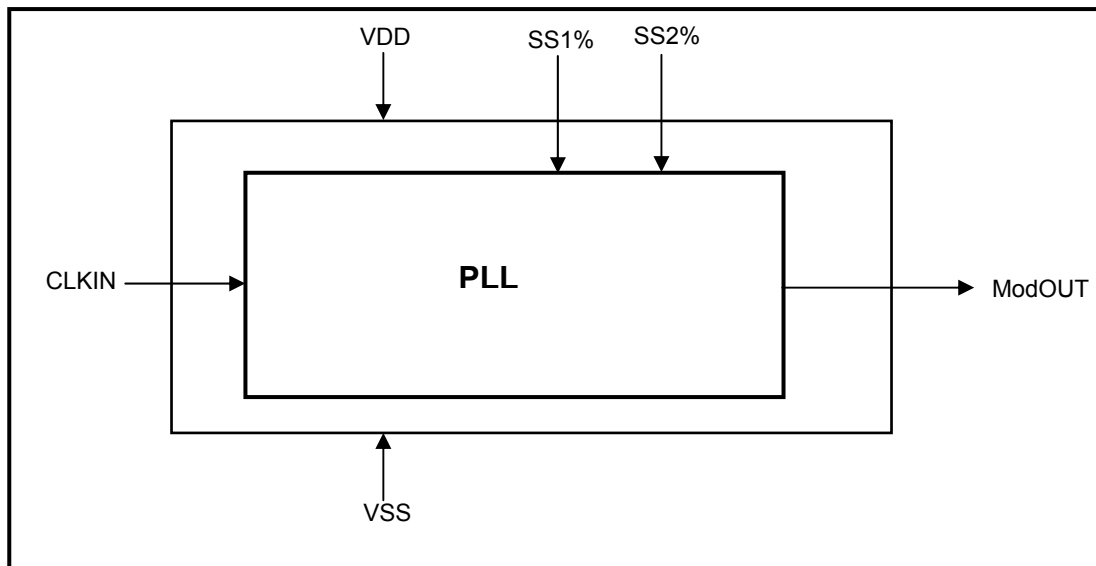

rev 0.3

Pin Configuration (6L TSOT- 26 Package)

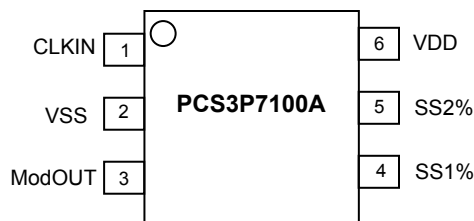

Pin Description

Pin#	Pin Name	Type	Description
1	CLKIN	I	External Reference Input frequency.
2	VSS	I	Ground to entire chip
3	ModOUT	O	Modulated Frequency Output
4	SS1%	I	Spread Deviation Selection Pin -1. Refer to “Spread Deviation Selection Table” for details. Has an Internal pull-up resistor.
5	SS2%	I	Spread Deviation Selection Pin -2. Refer to “Spread Deviation Selection Table” for details. Has an Internal pull-up resistor.
6	VDD	P	Power to entire chip

Spread Deviation Selection Table

SS2% Pin	SS1% Pin	Spread Deviation @ 55MHz
L	L	± 1.50%
L	H	± 1.25%
H	L	± 0.75%
H	H	± 1.00%

rev 0.3

Absolute Maximum Ratings

Symbol	Parameter	Rating	Unit
V _{DD} , V _{IN}	Voltage on any pin with respect to Ground	-0.5 to +4.6	V
T _{STG}	Storage temperature	-65 to +125	°C
T _A	Operating temperature	-40 to 85	°C
T _s	Max. Soldering Temperature (10 sec)	260	°C
T _J	Junction Temperature	150	°C
T _{DV}	Static Discharge Voltage (As per JEDEC STD22- A114-B)	2	KV

Note: These are stress ratings only and are not implied for functional use. Exposure to absolute maximum ratings for prolonged periods of time may affect device reliability.

DC Electrical Characteristics for 2.5V Supply

Symbol	Parameter	Min	Typ	Max	Unit
V _{IL}	Input low voltage	VSS - 0.3	-	0.8	V
V _{IH}	Input high voltage	2.0	-	VDD + 0.3	V
I _{IL}	Input low current	-	-	-35	µA
I _{IH}	Input high current	-	-	35	µA
V _{OL}	Output low voltage (VDD = 2.5V, I _{OL} = 8 mA)	-	-	0.6	V
V _{OH}	Output high voltage (VDD = 2.5V, I _{OH} = 8 mA)	1.8	-	-	V
I _{DD}	Static supply current*	-	-	2.5	mA
I _{CC}	Dynamic supply current (2.5V and no load)	-	10	-	mA
V _{DD}	Operating voltage	2.375	2.5	2.625	V
t _{ON}	Power-up time (first locked cycle after power-up)	-	-	5	mS
Z _{OUT}	Output Impedance	-	40	-	Ω

* CLKIN pin is pulled low

AC Electrical Characteristics for 2.5V Supply

Symbol	Parameter	Min	Typ	Max	Unit	
CLKIN	Input frequency	30	-	100	MHz	
ModOUT	Output frequency	30	-	100	MHz	
f _d	Frequency Deviation (SS2%=SS1%=1)	Input Frequency = 30MHz	-	±1.55	-	%
		Input Frequency = 100MHz	-	±0.35	-	
t _{LH} *	Output rise time (measured from 0.7V to 1.7V)	-	2.2	-	nS	
t _{HL} *	Output fall time (measured from 1.7V to 0.7V)	-	1.2	-	nS	
t _{JC}	Jitter (Cycle to cycle)	-	±250	-	pS	
t _D	Output duty cycle	40	50	60	%	

* t_{LH} and t_{HL} are measured into a capacitive load of 15pF

rev 0.3

DC Electrical Characteristics for 3.3V Supply

Symbol	Parameter	Min	Typ	Max	Unit
V _{IL}	Input low voltage	VSS - 0.3	-	0.8	V
V _{IH}	Input high voltage	2.0	-	VDD + 0.3	V
I _{IL}	Input low current	-	-	-35	μA
I _{IH}	Input high current	-	-	35	μA
V _{OL}	Output low voltage (VDD = 3.3V, I _{OL} = 8 mA)	-	-	0.4	V
V _{OH}	Output high voltage (VDD = 3.3V, I _{OH} = 8 mA)	2.5	-	-	V
I _{DD}	Static supply current*	-	-	3	mA
I _{CC}	Dynamic supply current (3.3V and no load)	-	12	-	mA
VDD	Operating voltage	3.0	3.3	3.6	V
t _{ON}	Power-up time (first locked cycle after power-up)	-	-	5	mS
Z _{OUT}	Output Impedance	-	40	-	Ω

* CLKIN pin is pulled low

AC Electrical Characteristics for 3.3V Supply

Symbol	Parameter	Min	Typ	Max	Unit	
CLKIN	Input frequency	30	-	100	MHz	
ModOUT	Output frequency	30	-	100	MHz	
f _d	Frequency Deviation (SS2%=SS1%=1)	Input Frequency = 30MHz	-	±1.55	-	%
		Input Frequency = 100MHz	-	±0.35	-	
t _{LH} *	Output rise time (measured from 0.8 to 2.0V)	-	1.5	-	nS	
t _{HL} *	Output fall time (measured at 2.0V to 0.8V)	-	1.1	-	nS	
t _{JC}	Jitter (Cycle to cycle)	-	±225	-	pS	
t _D	Output duty cycle	45	50	55	%	

*t_{LH} and t_{HL} are measured into a capacitive load of 15pF

rev 0.3

Package Information

6L TSOT26

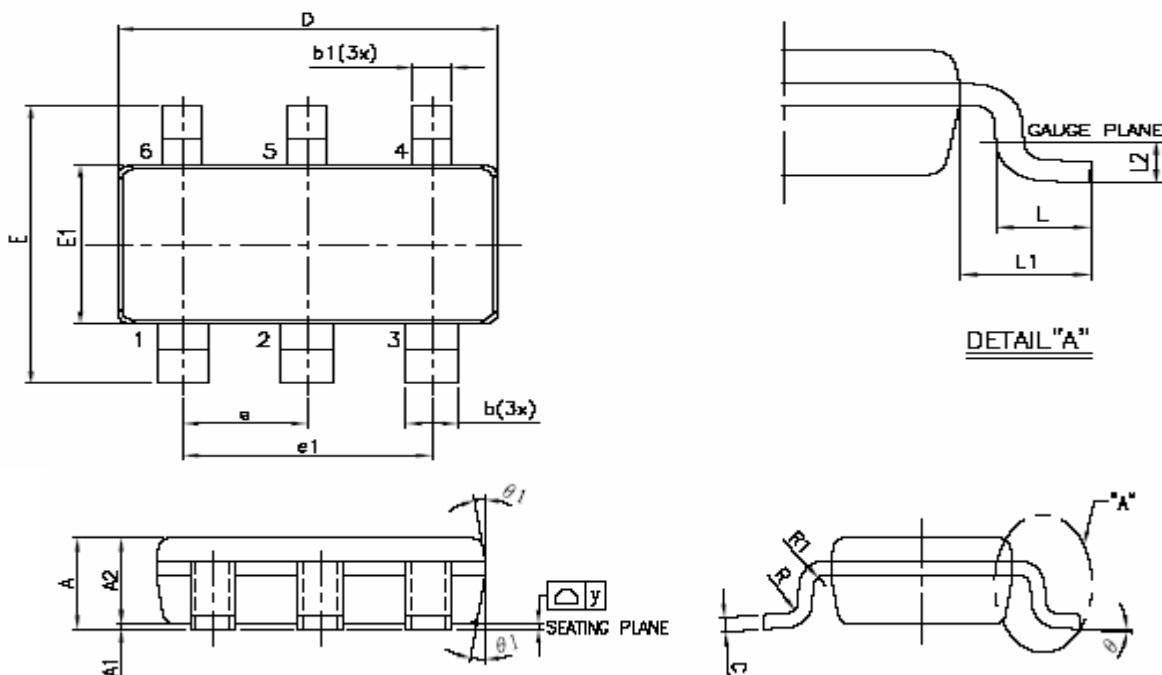

Symbol	Dimensions			
	Inches		Millimeters	
	Min	Max	Min	Max
A	0.0295	0.035	0.75	0.90
A1	0.00	0.0039	0.00	0.10
A2	0.0275	0.0314	0.70	0.80
b	0.0157	0.0197	0.40	0.50
b1	0.0118	0.0157	0.30	0.40
c	0.0031	0.0078	0.08	0.20
D	0.1141		2.90 REF	
E	0.1023	0.1181	2.60	3.00
E1	0.0590	0.0069	1.50	1.70
e	0.0374		0.95 BSC	
e1	0.0748		1.90 BSC	
L	0.0118	0.0236	0.30	0.60
L1	0.0236 REF		0.60 REF	
L2	0.0098 BSC		0.25 BSC	
R	0.0039	0.10
R1	0.0039	0.0098	0.10	0.25
θ	0°	8°	0°	8°
y	0.0039	0.10

rev 0.3

Ordering Codes

Part Number	Marking	Package Type	Temperature
PCS3P7100AG-06JT	AA2LL	6-Pin TSOT-26, TUBE, Green	Commercial
PCS3P7100AG-06JR	AA2LL	6-Pin TSOT-26, TAPE & REEL, Green	Commercial
PCS3I7100AG-06JT	AA4LL	6-Pin TSOT-26, TUBE, Green	Industrial
PCS3I7100AG-06JR	AA4LL	6-Pin TSOT-26, TAPE & REEL, Green	Industrial

Device Ordering Information

PCS3P7100AG-06JR

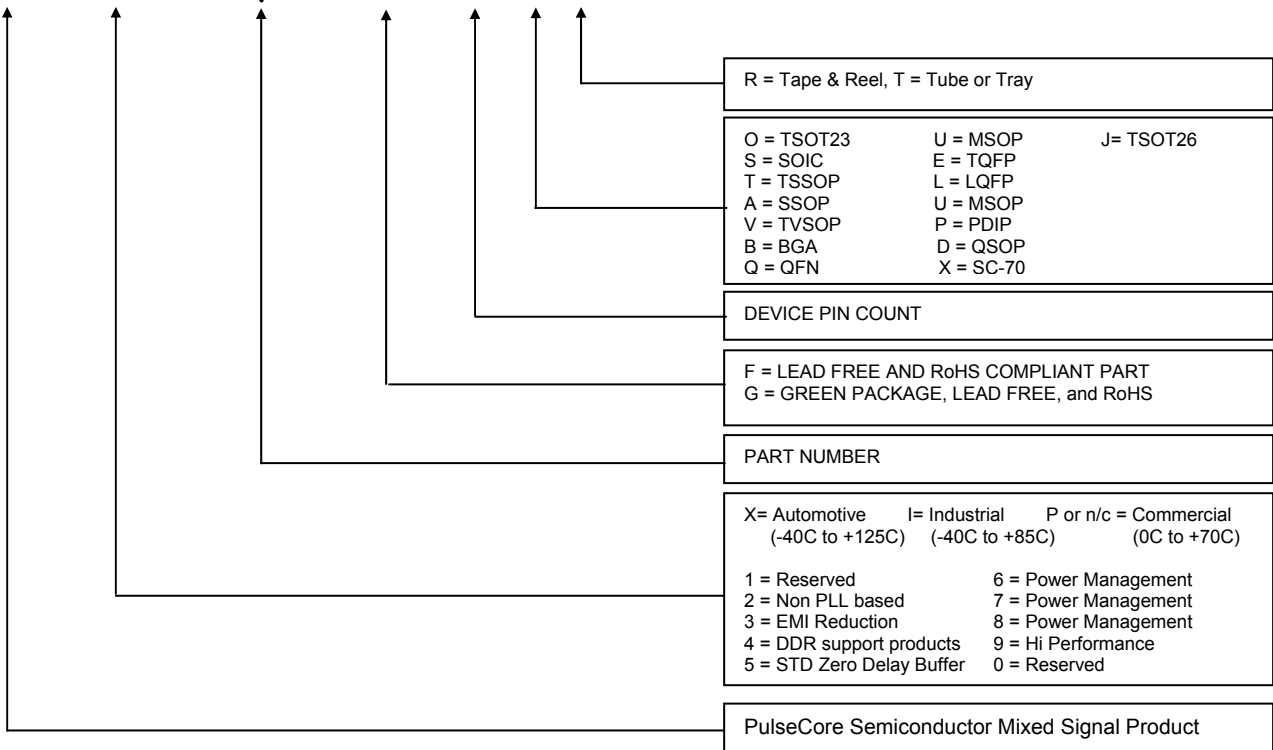

Licensed under U.S Patent Nos 5,488,627 and 5,631,921

Notice: The information in this document is subject to change without notice.



PulseCore Semiconductor Corporation
1715 S. Bascom Ave Suite 200
Campbell, CA 95008
Tel: 408-879-9077
Fax: 408-879-9018
www.pulsecoresemi.com

Copyright © PulseCore Semiconductor
All Rights Reserved
Preliminary Information
Part Number: PCS3P7100A
Document Version: v 0.3

Note: This product utilizes US Patent # 6,646,463 Impedance Emulator Patent issued to PulseCore Semiconductor, dated 11-11-2003

© Copyright 2006 PulseCore Semiconductor Corporation. All rights reserved. Our logo and name are trademarks or registered trademarks of PulseCore Semiconductor. All other brand and product names may be the trademarks of their respective companies. PulseCore reserves the right to make changes to this document and its products at any time without notice. PulseCore assumes no responsibility for any errors that may appear in this document. The data contained herein represents PulseCore's best data and/or estimates at the time of issuance. PulseCore reserves the right to change or correct this data at any time, without notice. If the product described herein is under development, significant changes to these specifications are possible. The information in this product data sheet is intended to be general descriptive information for potential customers and users, and is not intended to operate as, or provide, any guarantee or warranty to any user or customer. PulseCore does not assume any responsibility or liability arising out of the application or use of any product described herein, and disclaims any express or implied warranties related to the sale and/or use of PulseCore products including liability or warranties related to fitness for a particular purpose, merchantability, or infringement of any intellectual property rights, except as express agreed to in PulseCore's Terms and Conditions of Sale (which are available from PulseCore). All sales of PulseCore products are made exclusively according to PulseCore's Terms and Conditions of Sale. The purchase of products from PulseCore does not convey a license under any patent rights, copyrights; mask works rights, trademarks, or any other intellectual property rights of PulseCore or third parties. PulseCore does not authorize its products for use as critical components in life-supporting systems where a malfunction or failure may reasonably be expected to result in significant injury to the user, and the inclusion of PulseCore products in such life-supporting systems implies that the manufacturer assumes all risk of such use and agrees to indemnify PulseCore against all claims arising from such use.