

### Features

- 2-Way 0 Degree
- Surface Mount
- Tape and reel packaging available
- 260°C Reflow Compatible
- RoHS\* compliant

### Description

M/A-COM's MAPD-009278-5T1000 is a RoHS Compliant 2-way 0 degree RF power divider in a low cost, surface mount package. Ideally suit for 50Ohm system. Two 1.5pF capacitors and one 100Ohm resistor are required with this part.

The MAPD-009278-5T1000 is available in a SM-156 surface mount package and is designed to be utilized in both RoHS and standard reflow profiles. Parts are packaged in tape & reel.

### Product Image

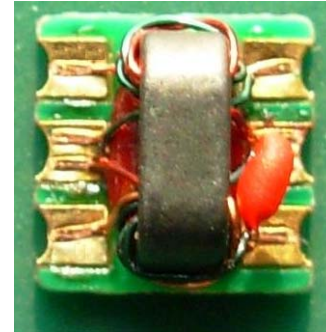

### Ordering Information

Part Number	Package
MAPD-009278-5T1000	Tape and Reel (2000 piece Reel)

### Electrical Specifications: $T_A = 25^\circ\text{C}$ , $Z_0 = 50\Omega$

Parameter	Test Conditions	Frequency	Units	Min	Typ	Max
RF Frequency	—	5 - 1000	MHz	—	—	—
Insertion Loss	Above 3dB	5 - 1000	dB	—	—	1.4
Amplitude Imbalance	—	5 - 1000	dB	—	—	0.6
Phase Imbalance	—	5 - 1000	Degrees	—	—	4
Input Return Loss	—	5 - 1000	dB	—	19	16.0
Output Return Loss	—	5 - 1000	dB	—	25	16.0
Isolation	—	5 - 1000	dB	—	20	16.0

### Pin Configuration

Pin No.	Function
1	Ground
2	External 1.5pF Cap
3	Output Port 1
4	Output Port 2
5	External 1.5pF Cap
6	Input

### Absolute Maximum Ratings

Parameter	Absolute Maximum
RF Power	250 mW
DC Current	240 mA <sup>2</sup>
Operating Temperature	-40°C to +85°C
Storage Temperature	-55°C to +125°C

1. Exceeding any one or combination of these limits may cause permanent damage to this device.
2. M/A-COM does not recommend sustained operation near these survivability limits.

\* Restrictions on Hazardous Substances, European Union Directive 2002/95/EC.

### Schematic With Off Chip Components

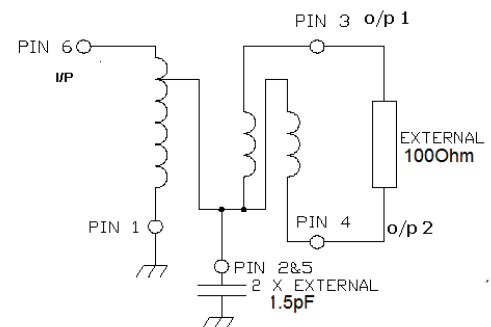

### Typical Performance Curves at +25°C

Insertion Loss

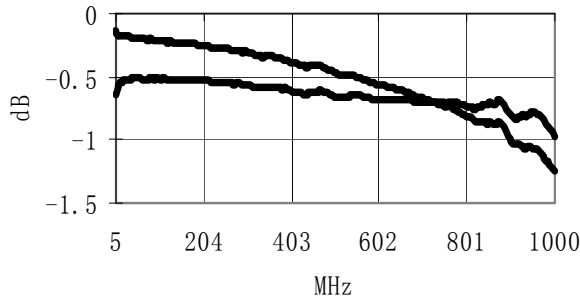

Amplitude Balance

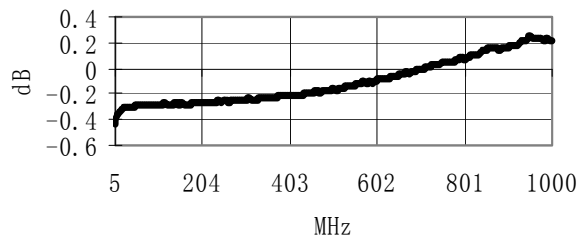

Phase Balance

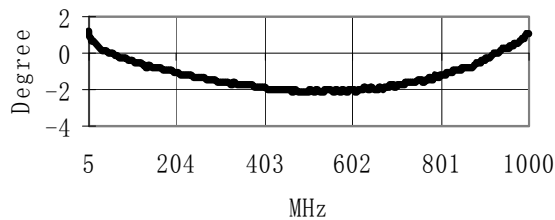

Input Return Loss

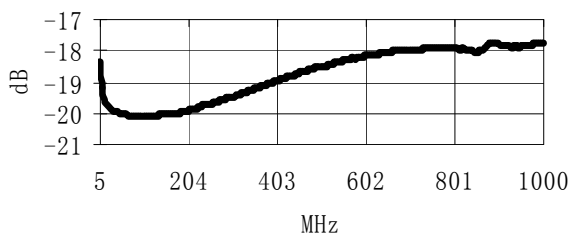

### SM -156 Package

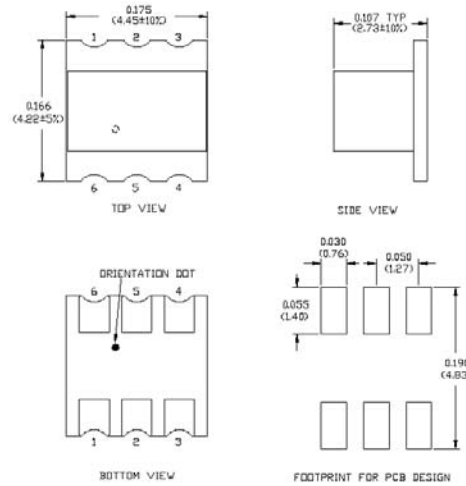

Unless otherwise specified dimensions in inches [mm]  
Tolerance: .xx ± .02, .xxx ± .010

Isolation

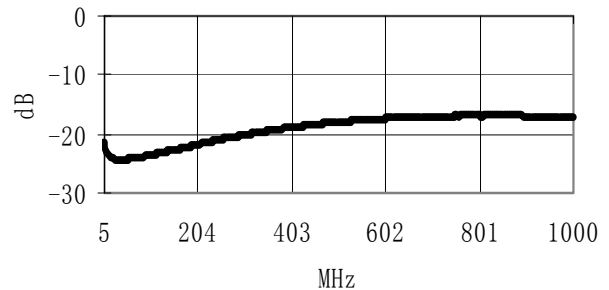

Output Return Loss

