

Thermal Cutout

Temperature Protection for Coils/Windings

FEATURES

- broad product range for all types of application and load
- small size
- maximum switch load
- good heat transfer
- high temperature sensitivity
- minimal contact resistance
- many approvals

F Type
B Type

DESCRIPTION

This thermostat operates as a **thermal cutout**. A thermally sensitive bimetal snap-element with double contacts (single contacts for type F 11) either opens or closes an electrical circuit by switching at a pre-set response temperature. Reset follows automatically after a considerable drop in temperature.

Heat transfer occurs from all sides through convection, radiation or conduction in gaseous or solid media. The circular base plate conducts heat onto the bimetal snap-element, thus also allowing its use as a surface temperature cutout.

APPLICATIONS

Thermal protection and- under certain conditions - temperature control of electrical machinery and equipment.

Examples

Single phase motors	Heating elements	Chokes
Generators	Signal transmitters	Coils
Convertors	Fire detectors	Power supplies
Transformers	Magnets	Inverters
Pumps	Relays	



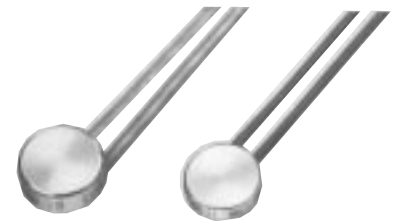
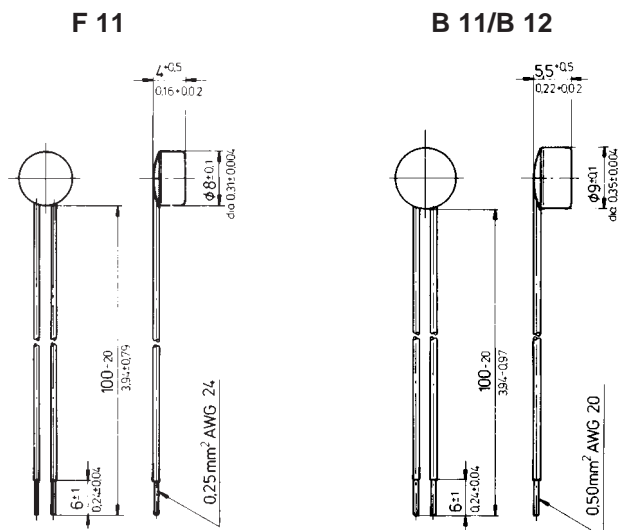



DIMENSIONS



CANTHERM

8415 Mountain Sights Avenue • Montreal (Quebec), H4P 2B8, Canada
 Tel: (514) 739-3274 • 1-800-561-7207 • Fax: (514) 739-290
 E-mail : sales@cantherm.com • Website: www.cantherm.com

TECHNICAL DATA

Type	F 11	F 11U	B 11	B 12
Voltage rating 50 – 60 Hz*	250 V	250 V	250 V	250 V
Current rating at $\cos \varphi = 1,0^*$	2,0 A	2,0 A	6,3 A	6,3 A
Current rating at $\cos \varphi = 0,6^*$	1,2 A	1,2 A	4,0 A	4,0 A
max. load 48h** at $\cos \varphi = 1.0$	3,0 A	4,0 A	8,0 A	10,0 A
Contact arrangement	Normally closed N-C 			
	Normally open N-O			
Switch operations at rated current*	E I (10 000)	E I (10 000) 35E2 (3500)	E I (10 000)	E I (10 000)
Contact resistance***	< 40 mΩ	< 40 mΩ	< 40 mΩ	< 40 mΩ
Response temperature range	+70 °C to +160 °C 343 K to 433 K	+70 °C to +160 °C 343 K to 433 K	+50 °C to +160 °C 323 K to 433 K	+50 °C to +160 °C 323 K to 433 K
Tolerance (minimum)	±5 K ±10 K ±15 K	±5 K ±10 K ±15 K	±5 K ±10 K ±15 K	±5 K ±10 K ±15 K
Max. permanent temperature of switch mechanism*	T 175	T 175	T175	T 175
Housing material	silver-plated steel hard epoxy	silver-plated steel hard epoxy	nickel-plated steel Duroplast	nickel-plated steel Duroplast
Protection	sealed against ingress of dust, lacquer, oil, resin etc.			
Strength of shape without permanent deformation	800 N/mm ²	800 N/mm ²	900 N/mm ²	900 N/mm ²
Vacuum tightness Δ	standard Ref. P102	standard Ref. P102	standard Ref. P102	standard Ref. P102
Rate of leak	0.133–0.0133 bar cm ³ /s	0.133–0.0133 bar cm ³ /s	0.133–0.0133 bar cm ³ /s	0.133–0.0133 bar cm ³ /s
Insulation resistance/ dielectric strength Execution according to U	Standard 1250 V 50–60 Hz P301 2000 V 50–60 Hz P302 2750 V 50–60 Hz P303 3750 V 50–60 Hz P304 4000 V 50–60 Hz			
Overheat protector ÜHS		10,0 (1,2) A		16,0 (8,0) A
Short circuit proof	10,0 A	10,0 A	36,0 A	36,0 A
Max. load 500 V AC	0.8 A	0.8 A	2.0 A	2.0 A
110 V AC	6.0 A	6.0 A	12.0 A	12.0 A
60 V DC	1.0 A	1.0 A	3.0 A	3.0 A
42 V DC	1.2 A	1.2 A	4.2 A	4.2 A
6/12/24 V DC	1.8 A	1.8 A	5.5 A	5.5 A
Min. load	50 m A	50 m A	50 m A	50 m A

Note: * Approved ratings- other specific values on request.
** Cycling rate 72/h

*** Contact resistance in standard version.
Δ On request.

CURRENT SENSITIVITY

The thermostats are not current sensitive at rated currents. At loads above the rated values, upto maximum loading there is self-heating of the current-carrying contacts. If current sensitive cutouts are required, please refer to the data sheet „Thermal cutouts – current sensitive thermal protection for coils/windings (Nr. 395).

INSULATION RESISTANCE

Housing (with insulation)
to earth 2750Veff. AC P302
On request, in special housing,
upto 4000Veff. AC P304
Across open contacts, dependent
on response temperature 500Veff. AC
Voltage of coil depending on application,
please ask.

CONNECTIONS

Flexible leads or solid wire in different lengths and cross-sections are available – please ask.

RESPONSE TEMPERATURES, TOLERANCE

Temperature stepped in 5 °C intervals, and tolerance in K from 50 °C to 160 °C. Special switch-off and reset temperatures available on request.

Rate of temperature rise from 0.1 K/min. to max. 1.0 K/min.

Insulation of the housing will slow down the cutout's response.

Standard reset temperature between 5 K and 50 K, depending on response temperature.

QUALITY ASSURANCE

Production item testing
Voltage test, switch function
Nominal switching temperature
Random sample quality testing
Life expectancy to VDE 0631/EN 60730
Function test to AQL 1.0
Nominal response temperature AQL 1.0
Measurement tolerance ±2 °C AQL 4.0
Other values AQL 4.0

CONNECTIONS (Standard)

Type	Lead length standard	Code	Temperature Class (VDE)	Cross section	Coating/Insulation	Conductor	Colour
F 11	100 ⁻²⁰ mm	L510	B	0.25 mm ²	Textil/Lack Polyolefine PTFE	tinned copper	black
		L517	F	0.25 mm ²		tinned copper	blue
		L515	C	0.24 mm ²		silvered copper	white
B 11/ B 12	100 ⁻²⁰ mm	L520	B	0.5 mm ²	Textil/Lack Polyolefine FEP PTFE	tinned copper	yellow
		L531	F	0.5 mm ²		tinned copper	blue
		L528	H	0.5 mm ²		tinned copper	white
		L540	C	0.62 mm ²		silvered copper	white

Lead stripping: standard 6 ± 1 mm

a = ends stripped

b = half insulated

c = stripped and lead end tinned

INSULATION

Standard versions of the thermostats are un-insulated.

If insulation is desired, the standard insulation (class) should be selected for the appropriate response temperature or max. operating temperature.

The temperature resistance of the connecting leads allows for the nominal response temperature of the cutout.

The leads used are consistent with insulation class and dielectric strength stated.

Example:

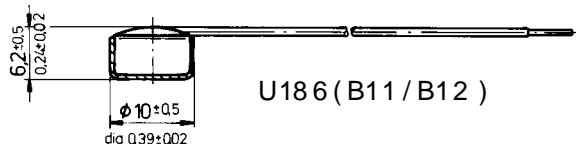
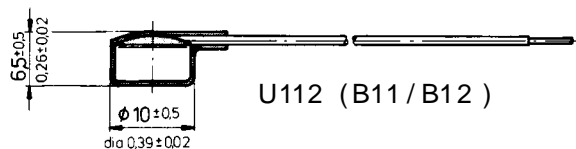
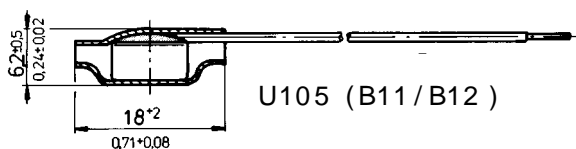
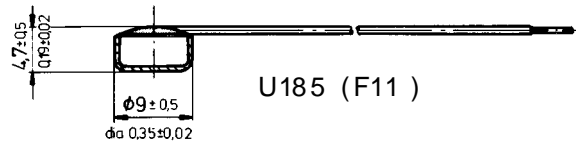
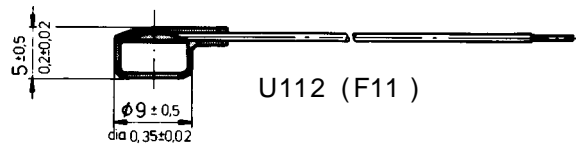
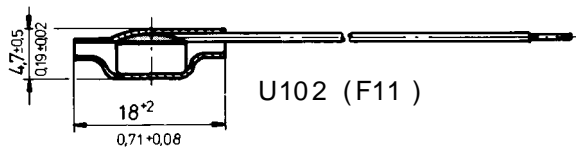

Type	Version	Description	Insulation Class (VDE)
F 11	U 102	Standard SHB transparent shrink material	B
F 11	U 104	SSB radiation cross-linked heat-shrink sleeve black for normally closed	B
F 11	U 106	SSH radiation cross-linked heat-shrink sleeve transparent	F
F 11	U 116	Standard shrink sleeve PTFE	H
F 11	U 112	UWF coating hard epoxy	F
F 11	U 185	Standard Insulation cap ST	B
F 11	U 180	Insulation cap PET	H
B 11/B 12	U 103	Standard SHB transparent shrink material	B
B 11/B 12	U 105	SSB radiation cross-linked heat-shrink sleeve black for normally closed	B
B 11/B 12	U 109	red for normally open	
B 11/B 12	U 107	SSH radiation cross-linked heat-shrink sleeve transparent	F
B 11/B 12	U 139	shrink sleeve PTFE	H
B 11/B 12	U 112	UWF coating hard epoxy	F
B 11/B 12	U 186	Standard Insulation cap ST	B
B 11/B 12	U 181	Insulation cap PET	H

SPECIAL VERSIONS

INSULATION

Special versions are available, please ask.

MOUNTINGS

Single screw fixing bracket (CuBe) for use on flat surfaces with full insulation or cap.

F 11 B 224

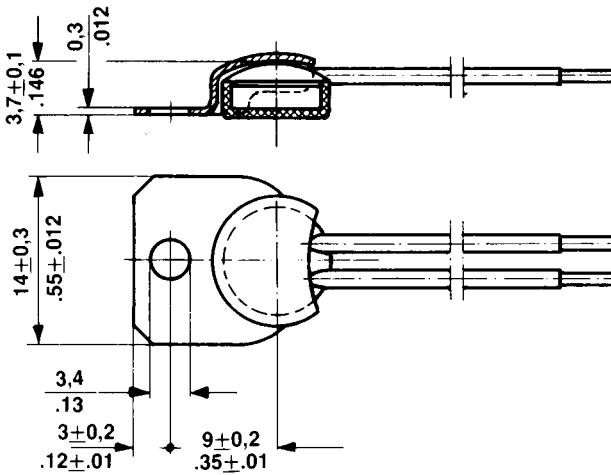

B 11/B 12 B 245

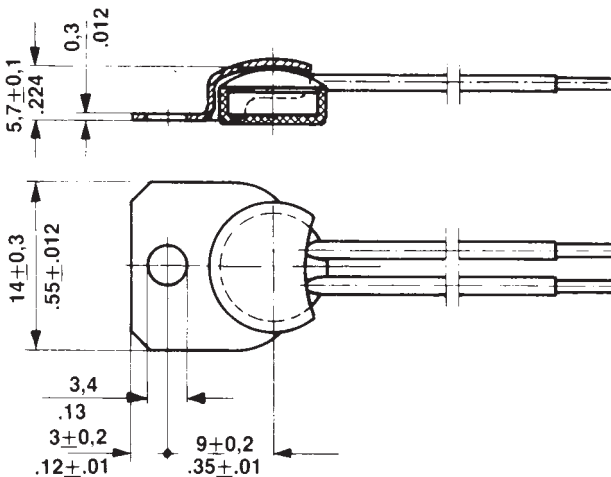

APPROVALS

Life expectancy, voltage rating, current rating to VDE 0631 or EN 60730, see page 2.

Additional approvals apply for many countries. Information on request.

INSTALLATION TIPS

When installing thermal cutouts, it is important to ensure good heat transfer. The heat sensitive surface (base) should be placed on/near to the heat source. Heat conducting paste or paint will improve heat transfer.

It should be noted that standard version thermal cutouts have a current-carrying housing, and that with electrically insulated cutouts the impaired heat transfer can alter the effective switching temperature. This should be borne in mind when selecting the nominal response temperature.

With single-phase motors, the cutout should switch the mains supply. It will then switch the motor off if there is any undesirable heating. The motor short circuit current will then be safely interrupted, if this is larger than the current rating of the cutout.

For three-phase motors, the motor current will not be interrupted direct from the mains supply. The cutout installed in the windings should switch in series with the magnetic coil of the contactor. The electrical supply to the cutouts should lead either singly or together from the motor terminals so that connection with the control circuit is possible.

PRODUCT MARKING

Example:

B12V Type, version
12510 Nominal response temperature
(3 digits),
Tolerance \pm in K (2 digits)
074E Month (2 digits), Year (1 digit),
Country code

MARKING

Normally closed = blue epoxy, Code No. 2
Normally open = red epoxy, Code No. 1
Special markings on request.

ORDERING EXAMPLE

Quantity	Type	Temperature	Version
800	B 12	125 °C \pm 10 K	U 103

We reserve the right to change specifications without prior notice.

CANTHERM

8415 Mountain Sights Avenue • Montreal (Quebec), H4P 2B8, Canada
Tel: (514) 739-3274 • 1-800-561-7207 • Fax: (514) 739-290
E-mail : sales@cantherm.com • Website: www.cantherm.com

