

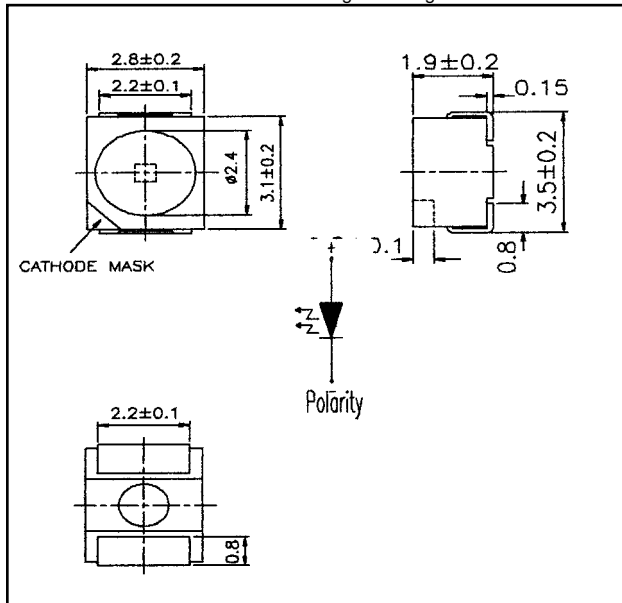

Weight: 2.0 mg Unit: mm



Product specifications contained herein may be changed without prior notice. It is therefore advisable to contact Purdy Electronics before proceeding with the design of equipment incorporating this product.

# AND6BD

## InGaN Ultra Bright Blue TOP LEDs

### Features

• RoHS Compliant

- P-LCC-2 package with optical indicator
- Compatible with automatic placement equipment
- Suitable for infrared reflow, vapor phase reflow, and wave solder processes
- Wide viewing angle
- Low (2mA) current operation
- Inter reflector
- Ideal for (LCD) backlight and pipe applications
- Pb-Free, RoHS

### Maximum Ratings ( $T_a = 25^\circ\text{C}$ )

Characteristics	Symbol	Rating	Unit
Forward Current	$I_F$	30	mA
Reverse Voltage	$V_R$	5	V
Power Dissipation	$P_D$	130	mW
Operating Temp. Range	$T_{Opr}$	-40 to 85	$^\circ\text{C}$
Storage Temp. Range	$T_{Stg}$	-40 to 100	$^\circ\text{C}$
Electrostatic Discharge	ESD	1000	V
Peak Forward Current (Duty 1/10 @ 1Khz)	IFP	100	mA

### Electro-Optical Characteristics ( $T_a = 25^\circ\text{C}$ )

Characteristics	Symbol	Test Condition	Minimum	Typical	Maximum	Unit
Forward Voltage	$V_F$	$I_F = 20 \text{ mA}$	2.7	3.2	3.7	V
Reverse Current	$I_R$	$V_R = 5 \text{ V}$	-	-	50	$\mu\text{A}$
Luminous Intensity	$I_V$	$I_F = 20 \text{ mA}$	90	135	180	mcd
Peak Emission Wavelength	$\lambda_P$	$I_F = 20 \text{ mA}$	-	468	-	nm
Spectral Line Half Width	$\Delta\lambda$	$I_F = 20 \text{ mA}$	-	26	-	nm
Dominant Wavelength	$\lambda_d$	$I_F = 20 \text{ mA}$	-	470	-	nm
Full Viewing Angle	$2\theta_{1/2}$	$I_F = 20 \text{ mA}$	-	120	-	degree

### Precaution

Please be careful of the following:

1. Manual soldering: maximum temperature of iron tip:  $260^\circ\text{C}$  max.  
Soldering time: within 5 sec. per solder-land  
Soldering portion of lead: up to 1.6 mm from the body of the device
2. Reflow solder: recommended condition is as follows:

3. Absolute secure counter measures against static electricity and surge should be taken when handling these products. It is recommended to use wrist band or antistatic gloves when handling these LEDs.

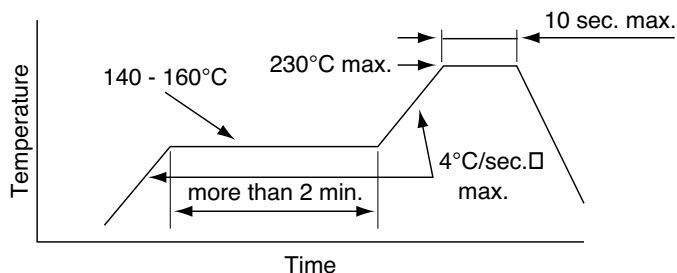

for reflow soldering

