

GBJ15005 THRU GBJ1510

GLASS PASSIVATED BRIDGE RECTIFIER

VOLTAGE: 50-1000V

CURRENT: 15.0A

FEATURES

- Low leakage
- Low forward voltage
- Surge overload ratings-240 Amperes

MECHANICAL DATA

- **Case:** Molded plastic
- **Epoxy:** UL 94V-0 rate flame retardant
- **Lead:** MIL-STD- 202E, Method 208 guaranteed
- **Polarity:** Symbols molded or marked on body
- **Mounting:** Thru hole for 6# screw
- **Weight:** 6.6 grams

GBJ

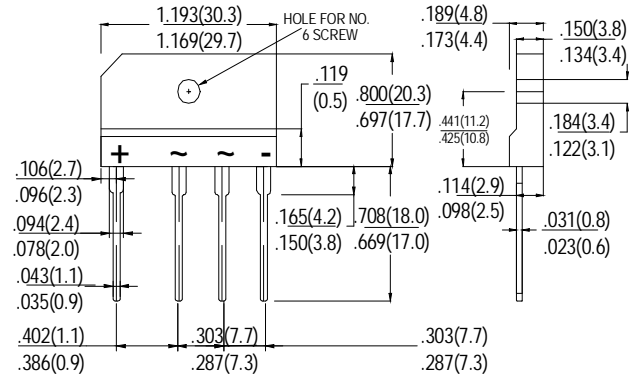

Dimensions in inches and (millimeters)

MAXIMUM RATINGS AND ELECTRICAL CHARACTERISTICS

Ratings at 25°C ambient temperature unless otherwise specified.

Single phase, half wave, 60Hz, resistive or inductive load.

For capacitive load, derate current by 20%.

	SYMBOL	GBJ 15005	GBJ 1501	GBJ 1502	GBJ 1504	GBJ 1506	GBJ 1508	GBJ 1510	units
Maximum Recurrent Peak Reverse Voltage	V_{RRM}	50	100	200	400	600	800	1000	V
Maximum RMS Bridge Input Voltage	V_{RMS}	35	70	140	280	420	560	700	V
Maximum DC Blocking Voltage	V_{DC}	50	100	200	400	600	800	1000	V
Maximum Average Forward rectified Output Current at $T_C=100^\circ C$	I_o	15							A
Peak Forward Surge Current 8.3ms single half sine-wave superimposed on rate load (JEDEC method)	I_{FSM}	240							A
Maximum Forward Voltage Drop per element at 7.5 A DC	V_F	1.05							V
Maximum DC Reverse Current at Rated DC Blocking Voltage per element	I_R	@ $T_A=25^\circ C$							μA
		@ $T_A=125^\circ C$							
I^2t Rating for Fusing ($t<8.3ms$)	I^2t	240							A^2S_{ec}
Typical Junction Capacitance per Element(Note 1)	C_J	60							pF
Typical Thermal Resistance, Junction to Case (Note 2)	$R_{\theta JA}$	2.7							$^\circ C/W$

Notes: 1. Measured at 1.0 MHz and applied reverse voltage of 4.0V DC.

2. Thermal resistance from junction to case per element. Unit mounted on 150 x 150 x 1.6mm copper plate heat sink.