



CX2HSM CRYSTAL

16 kHz to 600 kHz

Miniature Surface Mount
Quartz Crystal for Series Oscillators

DESCRIPTION

The CX2HSM quartz crystals are leadless devices designed for surface mounting on printed circuit boards or hybrid substrates. These miniature crystals are intended to be used in Series oscillators. They are hermetically sealed in a rugged, miniature ceramic package. The CX2HSM crystal is manufactured using the STATEK-developed photolithographic process, and was designed utilizing the experience acquired by producing millions of crystals for industrial, commercial, military and medical applications. Maximum process temperature should not exceed 260°C.

FEATURES

- Miniature tuning fork design
- High shock resistance
- Compatible with hybrid or PC board packaging
- Low aging
- Full military testing available
- Designed and manufactured in the USA

SUGGESTED LAND PATTERN

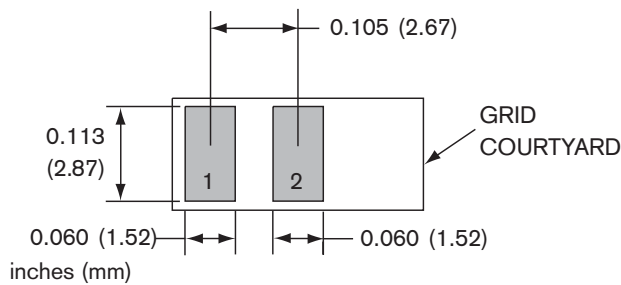

CONVENTIONAL SERIES OSCILLATOR CIRCUIT

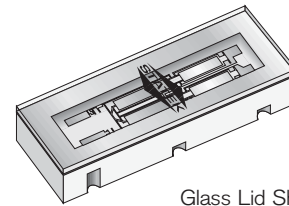
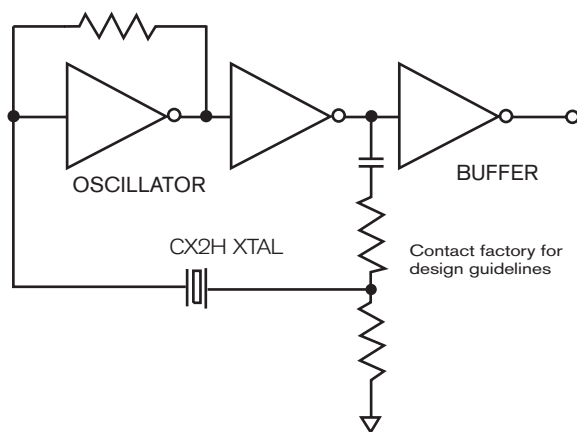

Glass Lid Shown

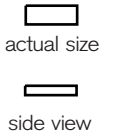

PACKAGE DIMENSIONS

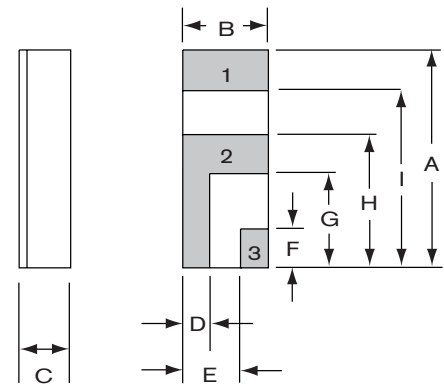

DIM	TYP.		MAX.	
	inches	mm	inches	mm
A	0.260	6.60	0.275	6.99
B	0.094	2.39	0.108	2.74
C	-	-	see below	
D	0.035	0.89	0.045	1.14
E	0.059	1.50	0.069	1.75
F	0.050	1.27	0.060	1.52
G	0.105	2.67	0.115	2.92
H	0.155	3.94	0.165	4.19
I	0.210	5.33	0.220	5.59

DIM "C"	GLASS LID		CERAMIC LID	
	inches	mm	inches	mm
MAX				
SM1	0.065	1.65	0.075	1.91
SM2	0.067	1.70	0.077	1.96
SM3	0.070	1.78	0.080	2.03

Note: Terminal 1 is electrically connected internally to terminal 3

EQUIVALENT CIRCUIT

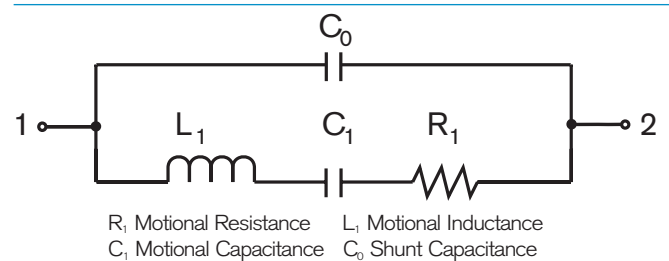

10137 - Rev B



SPECIFICATIONS

Specifications are typical at 25°C unless otherwise noted.

Specifications are subject to change without notice.

Frequency Range 16 kHz to 600 kHz

Standard Calibration Tolerance* (see table below)

Motional Resistance (R_1) Figure 1
MAX: 16-169.9 kHz, 2x Typ.
170-600 kHz, 2.5x Typ.

Motional Capacitance (C_1) Figure 2

Quality Factor (Q) Figure 3
MIN is 0.25x Typ.

Shunt Capacitance (C_0) 2.0 pF MAX.

Drive Level 16-24.9 kHz 1.5 μ W MAX.
25-600 kHz 3.0 μ W MAX.

Turning Point (T_0)** Figure 4

Temperature Coefficient (k) -0.035 ppm/°C²

Aging, first year 5 ppm MAX

Shock, survival*** 1,500 g peak, 0.3 ms, 1/2 sine

Vibration, survival*** 10 g RMS 20-2,000 Hz

Operating Temp. Range -10°C to +70°C (Commercial)
-40°C to +85°C (Industrial)
-55°C to +125°C (Military)

Storage Temp. Range -55°C to +125°C

Max Process Temperature 260°C for 20 sec.

* Tighter frequency calibration available.

** Other turning point available.

*** Higher shock and vibration available.

CX2H Standard Calibration Tolerance at 25°C

Frequency Range (kHz)			
16-74.9	75-169.9	170-249.9	250-600
± 30 ppm (0.003%)	± 50 ppm (0.005%)	± 100 ppm (0.01%)	±200 ppm (0.02%)
± 100 ppm (0.01%)	± 100 ppm (0.01%)	± 200 ppm (0.02%)	±500 ppm (0.05%)
± 1000 ppm (0.1%)	± 1000 ppm (0.1%)	± 2000 ppm (0.2%)	±5000 ppm (0.5%)

HOW TO ORDER CX2HSM CRYSTALS

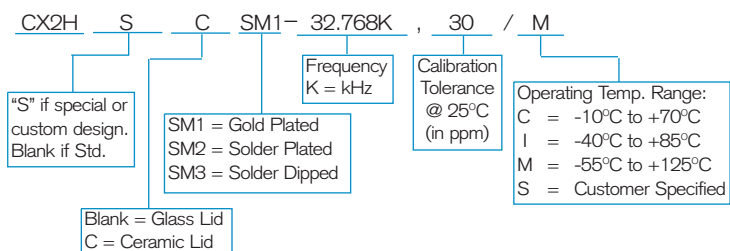

TERMINATIONS

Designation	Termination
SM1	Gold Plated
SM2	Solder Plated
SM3	Solder Dipped

FIGURE 1
CX2H TYPICAL MOTIONAL RESISTANCE (R_1)

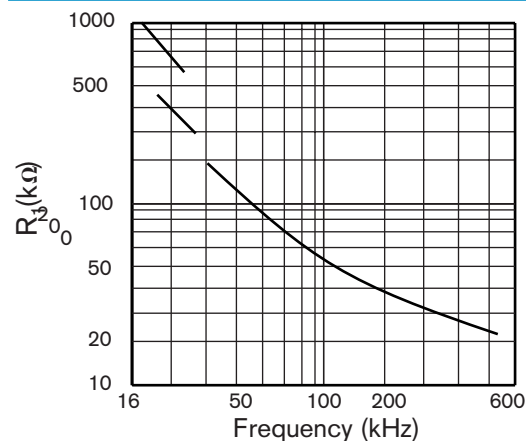

FIGURE 2
CX2H TYPICAL MOTIONAL CAPACITANCE (C_1)

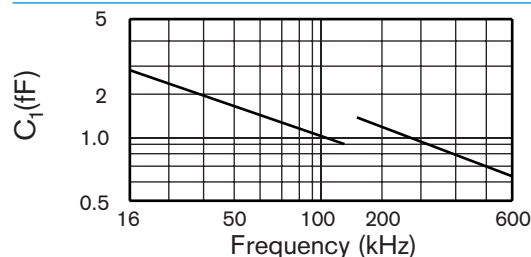

FIGURE 3
CX2H TYPICAL QUALITY FACTOR (Q)

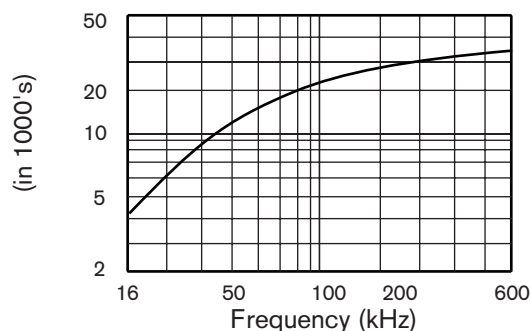
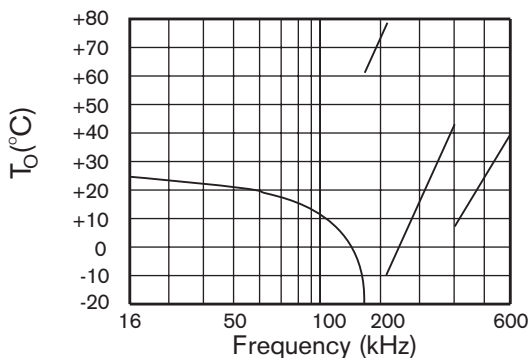

FIGURE 4
CX2H TYPICAL TURNING POINT TEMP. (T_0)



Note: Frequency f at temperature T is related to frequency f_0 at turning point temperature T_0 by:

$$\frac{f-f_0}{f_0} = k(T-T_0)^2$$

PACKAGING OPTIONS

CX2HSM - Tray Pack
-16mm tape, 7" or 13" reels
(Reference tape and reel data sheet 10109)