

**PART NUMBER:** CPE-750

**DESCRIPTION:** panel mount piezo indicators

**SPECIFICATONS**

operating frequency	3.6 ± 0.5 KHz	
operating voltage range	4 ~ 28 V DC	
current consumption	8 mA max.	at 12 V DC
sound pressure level	80 db min.	at 30 cm/12 V DC
rated voltage	12 V DC	
tone	continuous	at 12 V DC
operating temperature	-30 ~ +85° C	
storage temperature	-40 ~ +95° C	
dimensions	Ø37.8 x H23.5 mm	
weight	18.5 g max.	
material	ABS UL-94 1/16" HB (gray)	
terminal	pin type (Au plating)	
RoHS	yes	

**APPEARANCE DRAWING**

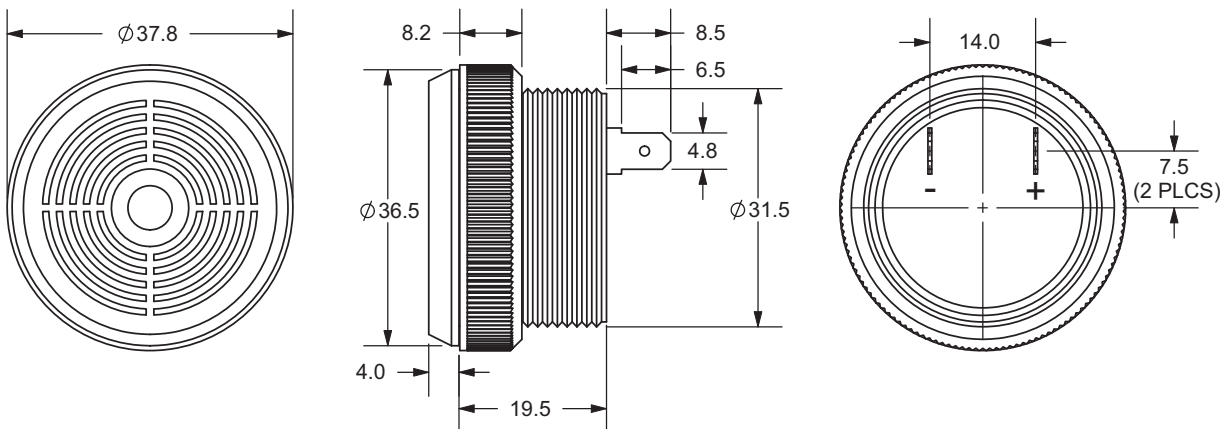
 tolerance: ±0.5  
 units: mm

**PART NUMBER:** CPE-750

**DESCRIPTION:** panel mount piezo indicators

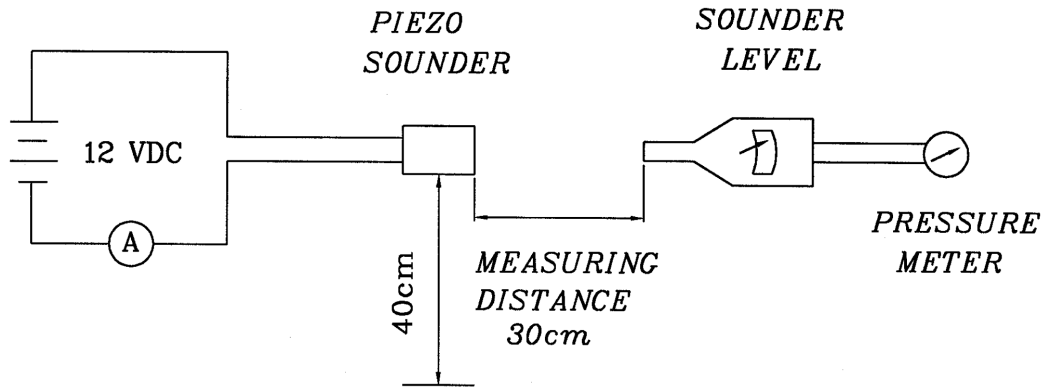
**MEASUREMENT METHOD**

S.P.L. Measuring Circuit

Mic: RION S.P.L. meter UC30 or equivalent

S.G.: Hewlett Packard 33120A function generator or equivalent

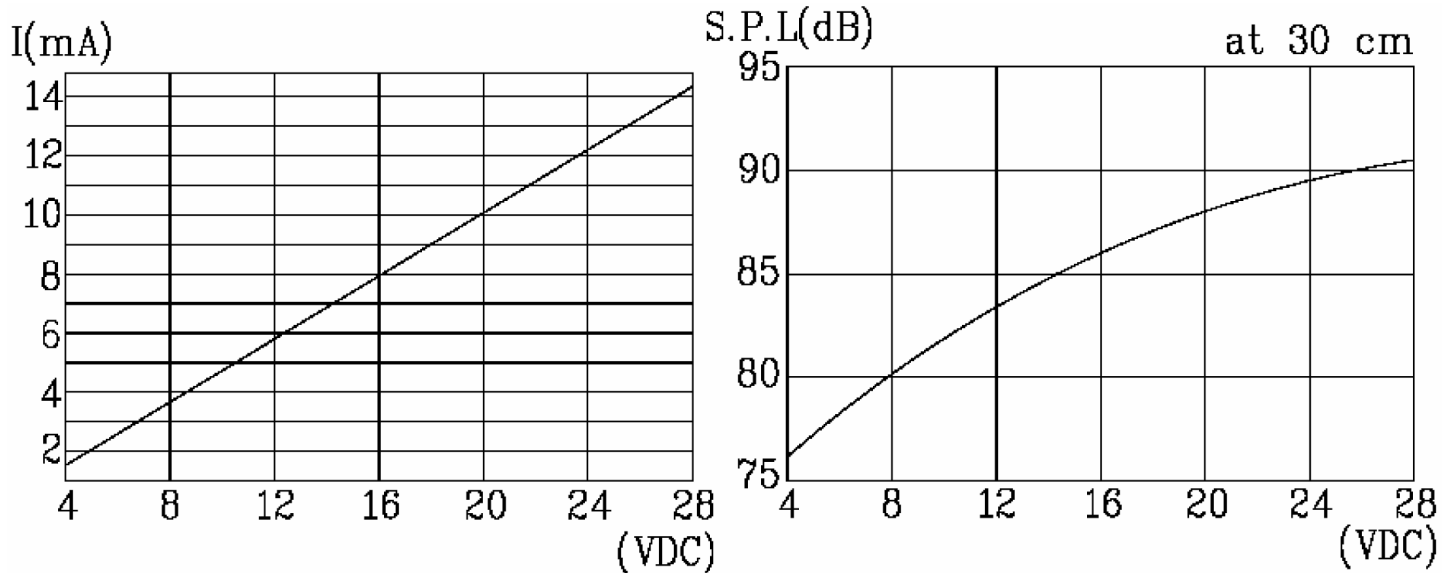
**CURRENT CONSUMPTION/SOUND PRESSURE LEVEL**

**PART NUMBER:** CPE-750

**DESCRIPTION:** panel mount piezo indicators

**MECHANICAL CHARACTERISTICS**

item	test condition	evaluation standard
solderability	Lead terminals are immersed in rosin for 5 seconds and then immersed in solder bath of $270 \pm 5^\circ\text{C}$ for $3 \pm 1$ seconds.	90% min. of the lead terminals will be wet with solder (except the edge of the terminal).
soldering heat resistance	Lead terminals are immersed up to 1.5mm from buzzer's body in solder bath of $300 \pm 5^\circ\text{C}$ for $3 \pm 0.5$ seconds or $260 \pm 5^\circ\text{C}$ for $10 \pm 1$ seconds.	No interference in operation.
terminal mechanical strength	For 10 seconds, the force of 9.8N (1.0kg) is applied to each terminal in axial direction.	No damage or cutting off.
vibration	The buzzer shall be measured after applying a vibration amplitude of 1.5 mm with 10 to 55 Hz band of vibration frequency to each of the 3 perpendicular directions for 2 hours.	The value of oscillation frequency/current consumption should be $\pm 10\%$ of the initial measurements. The SPL should be within $\pm 10\text{dB}$ compared with the initial measurement.
drop test	The part will be dropped from a height of 75 cm onto a 40 mm thick wooden board 3 times in 3 axes (X, Y, Z) for a total of 9 drops.	

**ENVIRONMENT TEST**

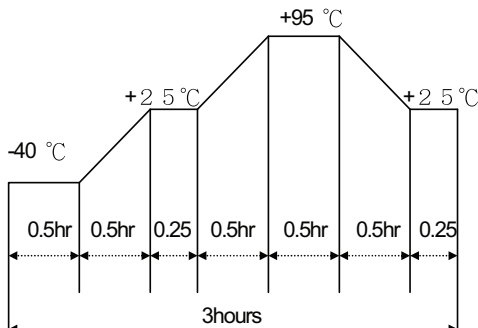
item	test condition	evaluation standard
high temp. test	After being placed in a chamber at $+95^\circ\text{C}$ for 240 hours.	The buzzer will be measured after being placed at $+25^\circ\text{C}$ for 4 hours. The value of the oscillation frequency/current consumption should be $\pm 10\%$ compared to the initial measurements. The SPL should be within $\pm 10\text{dB}$ compared to the initial measurements.
low temp. test	After being placed in a chamber at $-40^\circ\text{C}$ for 240 hours.	
humidity test	After being placed in a chamber at $+40^\circ\text{C}$ and $90 \pm 5\%$ relative humidity for 240 hours.	
temp. cycle test	The part shall be subjected to 5 cycles. One cycle will consist of: 	

**PART NUMBER:** CPE-750

**DESCRIPTION:** panel mount piezo indicators

**RELIABILITY TEST**

<b>item</b>	<b>test condition</b>	<b>evaluation standard</b>
operating (life test)	1. Continuous life test: The part will be subjected to 48 hours of continuous operation at +70°C with rated voltage applied.  2. Intermittent life test: A duty cycle of 1 minute on, 1 minutes off, a minimum of 5,000 times at room temp (+25 ±2°C) with rated voltage applied.	The buzzer will be measured after being placed at +25°C for 4 hours. The value of the oscillation frequency/current consumption should be ±10% compared to the initial measurements. The SPL should be within ±10dB compared to the initial measurements.

**TEST CONDITIONS**

standard test condition	a) temperature: +5 ~ +35°C	b) humidity: 45 - 85%	c) pressure: 860-1060 mbar
judgement test condition	a) temperature: +25 ±2°C	b) humidity: 60 - 70%	c) pressure: 860-1060 mbar

**PART NUMBER:** CPE-750

**DESCRIPTION:** panel mount piezo indicators

**PACKAGING**
