



High Voltage CMOS Boost White LED Driver



FEATURES

- Drives 6 to 8 White LEDs in series from 3V
- Up to 87% Efficiency
- Low Quiescent Ground Current 0.6mA
- Adjustable Output Current (up to 40mA)
- High Frequency 1MHz Operation
- High Voltage Power Switch
- Shutdown current less than 1µA
- Open LED low power mode
- Automatic Shutdown at 1.9V (UVLO)
- Thermal shutdown protection
- RoHS-compliant
- Thin SOT23 5-Lead (1mm max height)

APPLICATIONS

- Color LCD and keypad Backlighting
- Cellular Phones
- Handheld Devices
- Digital Cameras
- PDAs
- Portable Game Machine

ORDERING INFORMATION

Part Number	Package	Quantity per Reel	Package Marking
CAT4237TD-T3	TSOT23-5 ⁽¹⁾	3000	LT
CAT4237TD-GT3	TSOT23-5 ⁽²⁾	3000	UD

Notes: (1) Matte-Tin Plated Finish (RoHS-compliant).
 (2) NiPdAu Plated Finish (RoHS-compliant).

DESCRIPTION

The CAT4237 is a DC/DC step-up converter that delivers an accurate constant current ideal for driving LEDs. Operation at a constant switching frequency of 1MHz allows the device to be used with small value external ceramic capacitors and inductor. LEDs connected in series are driven with a regulated current set by the external resistor R₁. LED currents up to 40mA can be supported over a wide range of input supply voltages from 2.8V to 5.5V, making the device ideal for battery-powered applications. The CAT4237 high-voltage output stage is perfect for driving six, seven or eight white LEDs in series with inherent current matching in LCD backlight applications.

LED dimming can be done by using a DC voltage, a logic signal, or a pulse width modulation (PWM) signal. The shutdown input pin allows the device to be placed in power-down mode with “zero” quiescent current.

In addition to thermal protection and overload current limiting, the device also enters a very low power operating mode during “Open LED” fault conditions. The device is housed in a low profile (1mm max height) 5-lead thin SOT23 package for space critical applications.

For Ordering Information details, see page 13.

PIN CONFIGURATION

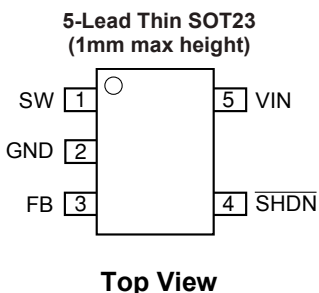

TYPICAL APPLICATION CIRCUIT

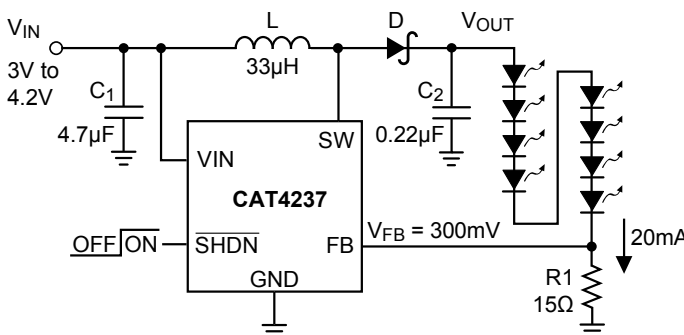

L: Sumida CDRH3D16-330
 D: Central CMDSH05-4 (rated 40V)
 C2: Taiyo Yuden UMK212BJ224 (rated 50V)

ABSOLUTE MAXIMUM RATINGS

Parameters	Ratings	Units
V _{IN} , FB voltage	-0.3 to +7	V
$\overline{\text{SHDN}}$ voltage	-0.3 to +7	V
SW voltage	-0.3 to 55	V
Storage Temperature Range	-65 to +160	°C
Junction Temperature Range	-40 to +150	°C
Lead Temperature	300	°C

RECOMMENDED OPERATING CONDITIONS

Typical application circuit with external components are shown on page 1.

Parameters	Range	Units
V _{IN}	2.8 to 5.5	V
SW pin voltage	0 to 30	V
Ambient Temperature Range	-40 to +85	°C
6, 7 or 8 LEDs	1 to 40	mA

Note:

(1) Thin SOT23-5 package thermal resistance $\theta_{JA} = 135^{\circ}\text{C}/\text{W}$ when mounted on board over a ground plane.

DC ELECTRICAL CHARACTERISTICS

V_{IN} = 3.6V, ambient temperature of 25°C (over recommended operating conditions unless specified otherwise).

Symbol	Parameter	Conditions	Min	Typ	Max	Unit
I _Q	Operating Current	V _{FB} = 0.2V V _{FB} = 0.4V (not switching)		0.6 0.1	1.5 0.6	mA
I _{SD}	Shutdown Current	V _{$\overline{\text{SHDN}}$} = 0V		0.1	1	μA
V _{FB}	FB Pin Voltage	8 LEDs with I _{LED} =20mA	285	300	315	mV
I _{FB}	FB pin input leakage				1	μA
I _{LED}	Programmed LED Current	R1 = 10Ω R1 = 15Ω R1 = 20Ω	28.5 19 14.25	30 20 15	31.5 21 15.75	mA
V _{IH} V _{IL}	$\overline{\text{SHDN}}$ Logic High $\overline{\text{SHDN}}$ Logic Low	Enable Threshold Level Shutdown Threshold Level	0.4	0.8 0.7	1.5	V V
F _{SW}	Switching Frequency		0.8	1.0	1.3	MHz
I _{LIM}	Switch Current Limit		350	450	600	mA
R _{SW}	Switch "On" Resistance	I _{SW} = 100mA		1.0	2.0	Ω
I _{LEAK}	Switch Leakage Current	Switch Off, V _{SW} = 5V		1	5	μA
	Thermal Shutdown			150		°C
	Thermal Hysteresis			20		°C
V _{UVLO}	Undervoltage Lockout (UVLO) Threshold			1.9		V
V _{OV-SW}	Overvoltage Threshold			35		V

PIN DESCRIPTION

VIN is the supply input for the internal logic. The device is compatible with supply voltages down to 2.8V and up to 5.5V. It is recommended that a small bypass ceramic capacitor (4.7µF) be placed between the VIN and GND pins near the device. If the supply voltage drops below 1.9V, the device stops switching.

SHDN is the shutdown logic input. When the pin is tied to a voltage lower than 0.4V, the device is in shutdown mode, drawing nearly zero current. When the pin is connected to a voltage higher than 1.5V, the device is enabled.

GND is the ground reference pin. This pin should be connected directly to the ground plane on the PCB.

SW pin is connected to the drain of the internal CMOS power switch of the boost converter. The inductor and the Schottky diode anode should be connected to the SW pin. Traces going to the SW pin should be as short as possible with minimum loop area. An over-voltage detection circuit is connected to the SW pin. When the voltage reaches 35V, the device enters a low power operating mode preventing the SW voltage from exceeding the maximum rating.

FB feedback pin is regulated at 0.3V. A resistor connected between the FB pin and ground sets the LED current according to the formula:

$$I_{LED} = 0.3V/R_1$$

The lower LED cathode is connected to the FB pin.

PIN DESCRIPTIONS

Pin #	Name	Function
1	SW	Switch pin. This is the drain of the internal power switch.
2	GND	Ground pin. Connect the pin to the ground plane.
3	FB	Feedback pin. Connect to the last LED cathode.
4	SHDN	Shutdown pin (Logic Low). Set high to enable the driver.
5	VIN	Power Supply input.

BLOCK DIAGRAM

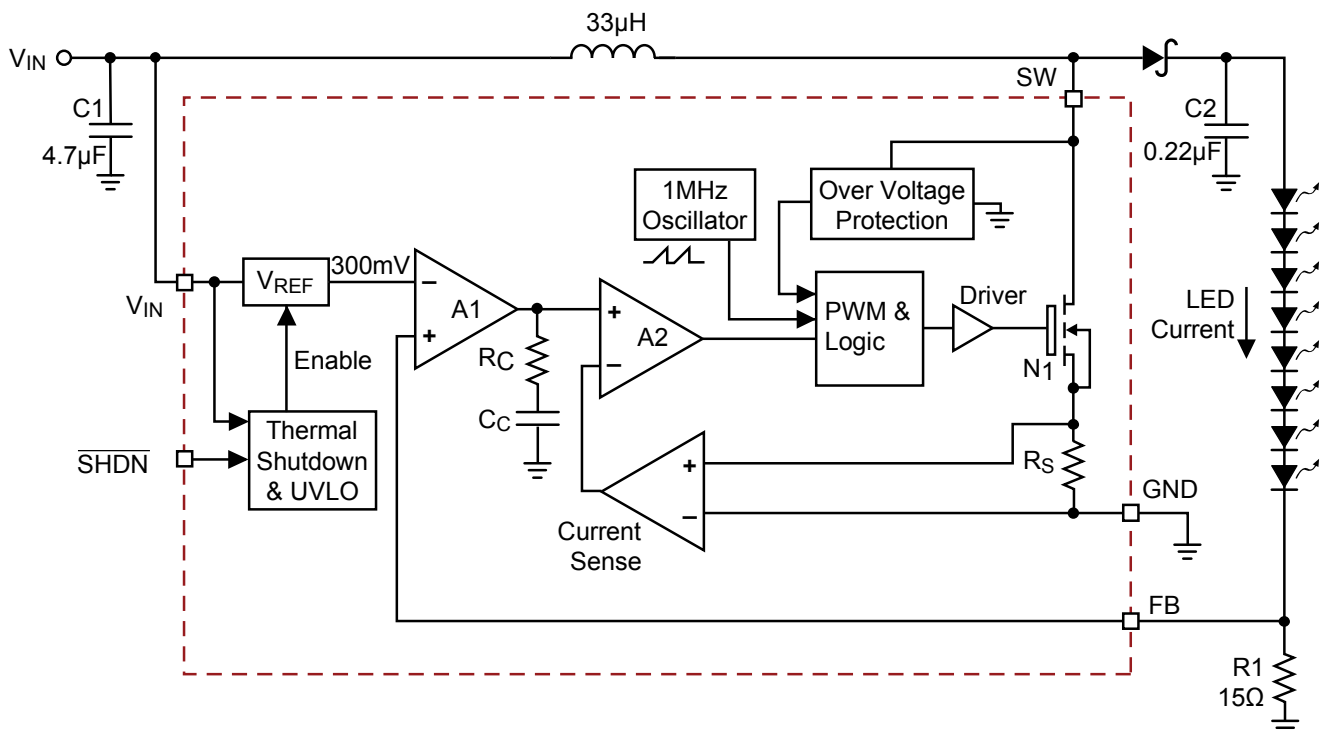

DEVICE OPERATION

The CAT4237 is a fixed frequency (1MHz), low noise, inductive boost converter that provides a constant current with excellent line and load regulation. The device uses a high-voltage CMOS power switch between the SW pin and ground to energize the inductor. When the switch is turned off, the stored energy in the inductor is released into the load via the Schottky diode.

The on/off duty cycle of the power switch is internally adjusted and controlled to maintain a constant regulated voltage of 0.3V across the feedback resistor connected to the feedback pin (FB). The value of the resistor sets the LED current accordingly ($0.3V/R_1$).

During the initial power-up stage, the duty cycle of the internal power switch is limited to prevent excessive in-rush currents and thereby provide a “soft-start” mode of operation.

While in normal operation, the device can deliver up to 40mA of load current into a string of up to 8 white LEDs.

In the event of a “Open LED” fault condition, where the feedback control loop becomes open, the output voltage will continue to increase. Once this voltage exceeds 35V, an internal protection circuit will become active and place the device into a very low power safe operating mode where only a small amount of power is transferred to the output. This is achieved by pulsing the switch once every 60µs and keep it on for about 1µs only.

Thermal overload protection circuitry has been included to prevent the device from operating at unsafe junction temperatures above 150°C. In the event of a thermal overload condition the device will automatically shutdown and wait till the junction temperatures cools to 130°C before normal operation is resumed.

Light Load Operation

Under light load condition (under 4mA) and with input voltage above 4.2V, the CAT4237 driving 6 LEDs, the driver starts pulse skipping. Although the LED current remains well regulated, some lower frequency ripple may appear.

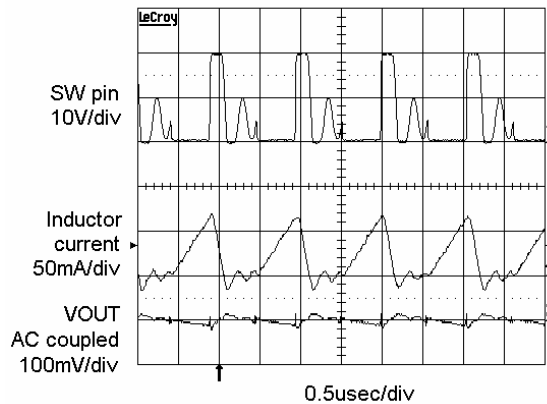
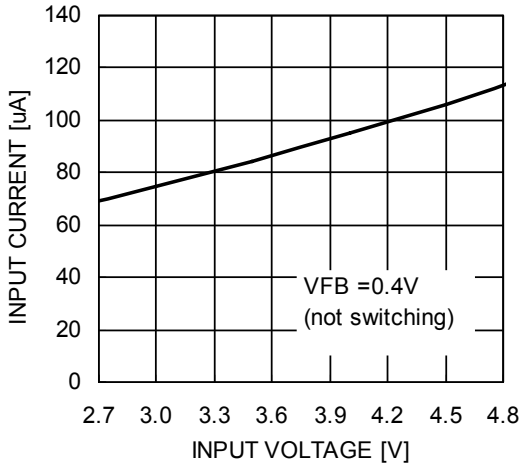

Figure 1. Switching Waveform $V_{IN} = 4.2V$, $I_{LED} = 4mA$

TYPICAL CHARACTERISTICS

$V_{IN} = 3.6V$, $C_{IN} = 4.7\mu F$, $C_{OUT} = 0.22\mu F$, $L = 33\mu H$ with 8 LEDs at 20mA, $T_{AMB} = 25^{\circ}C$, unless otherwise specified.

Quiescent Current vs. V_{IN} (Not Switching)



Quiescent Current vs. V_{IN} (Switching)

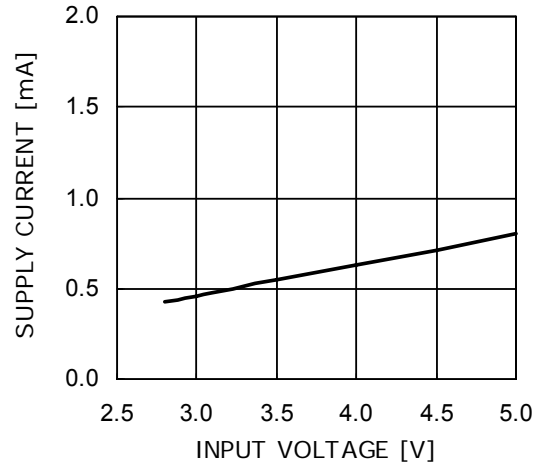

FB pin voltage vs. Supply Voltage

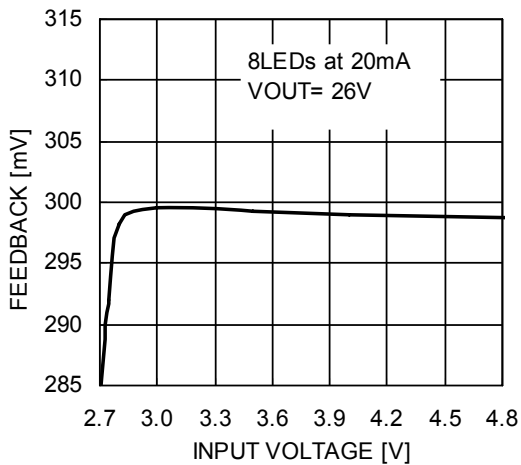

FB Pin Voltage vs. Output Current

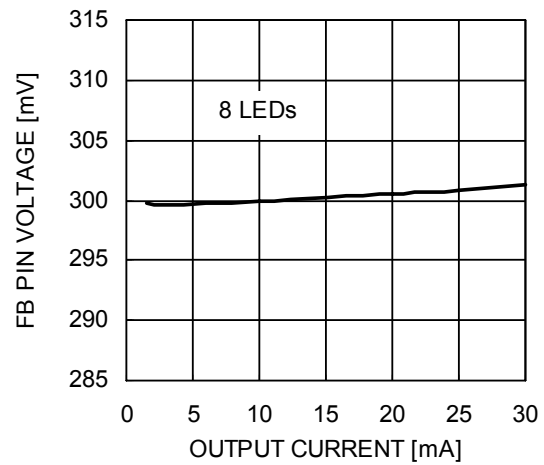

Switching Frequency vs. Supply Voltage

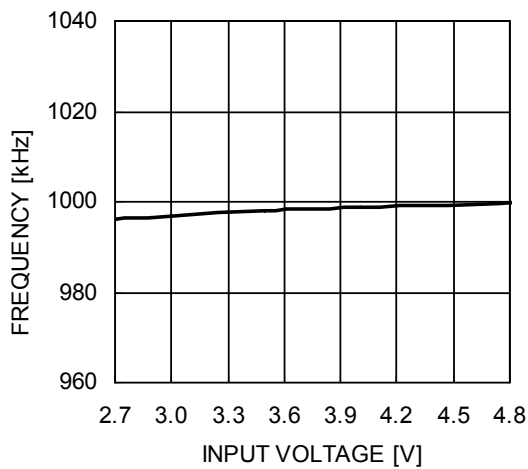

Switching Waveforms

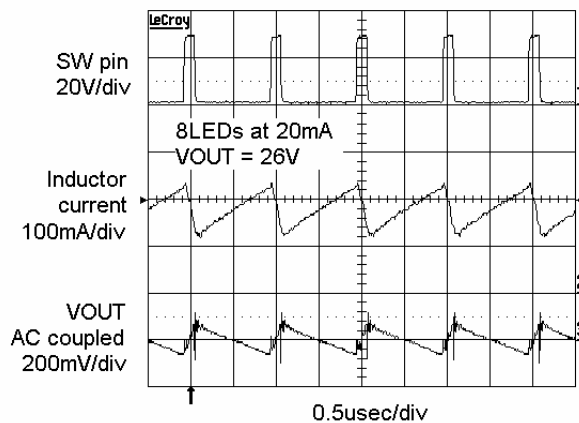

TYPICAL CHARACTERISTICS

$V_{IN} = 3.6V$, $C_{IN} = 4.7\mu F$, $C_{OUT} = 0.22\mu F$, $L = 33\mu H$ with 8 LEDs at 20mA, $T_{AMB} = 25^{\circ}C$, unless otherwise specified.

LED Current vs. Input Voltage (8 LEDs)

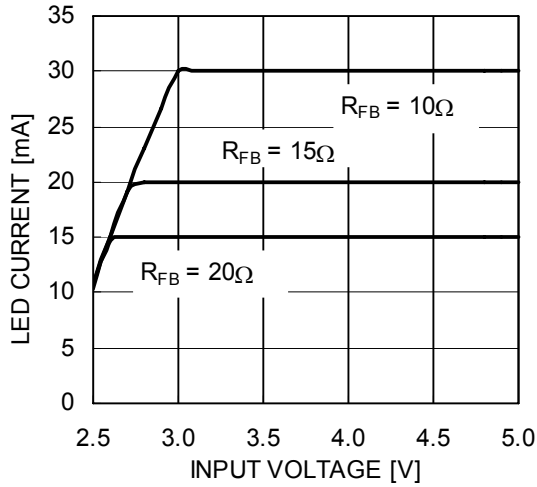

LED Current Regulation (20mA)

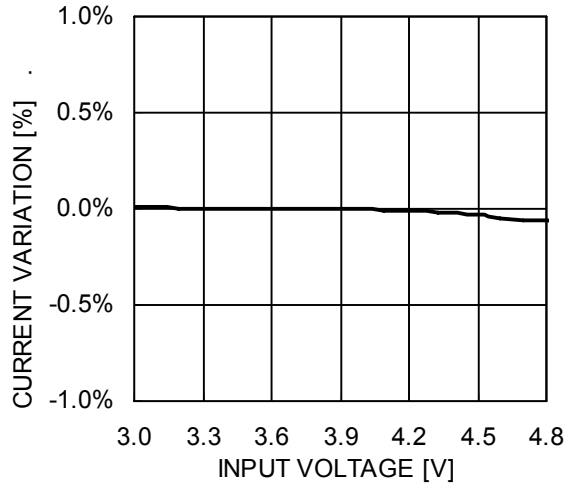

8 LED Efficiency vs. Load Current

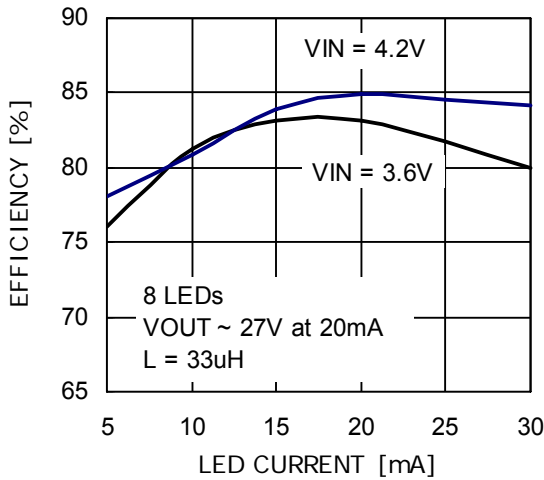

8 LED Efficiency vs. Input Voltage

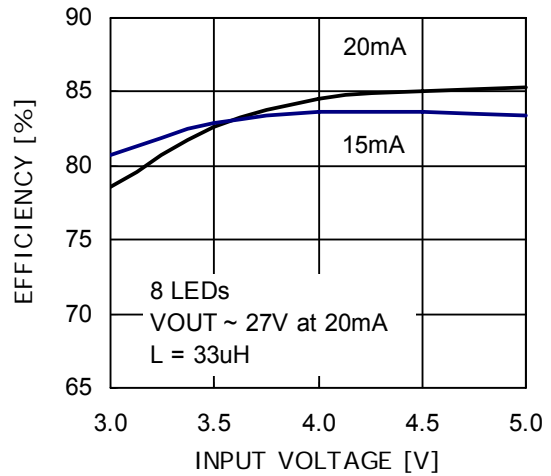

7 LED Efficiency vs. Load Current

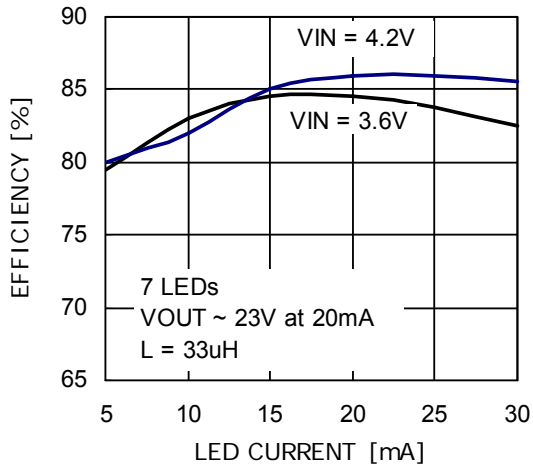

6 LED Efficiency vs. Load Current

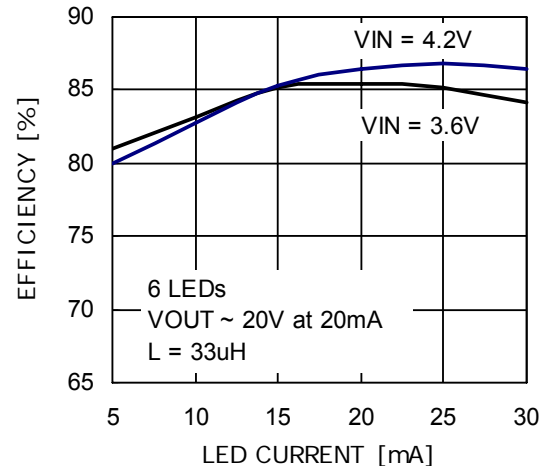

TYPICAL CHARACTERISTICS

$V_{IN} = 3.6V$, $C_{IN} = 4.7\mu F$, $C_{OUT} = 0.22\mu F$, $L = 33\mu H$ with 8 LEDs at 20mA, $T_{AMB} = 25^{\circ}C$, unless otherwise specified.

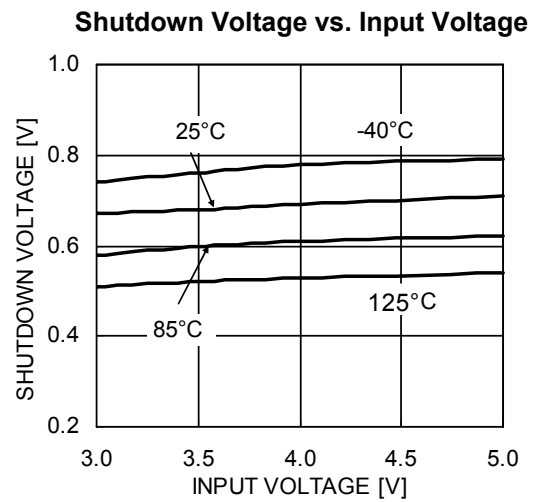
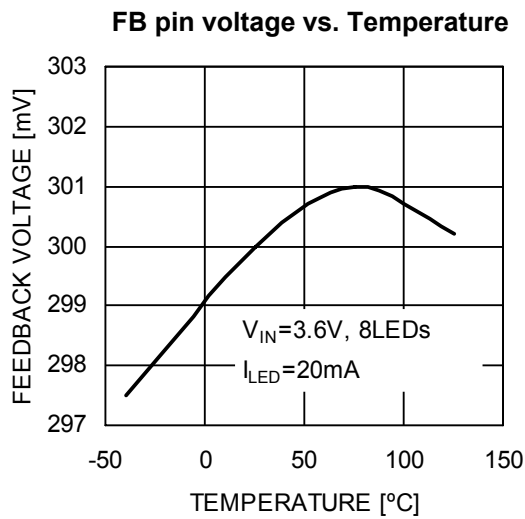
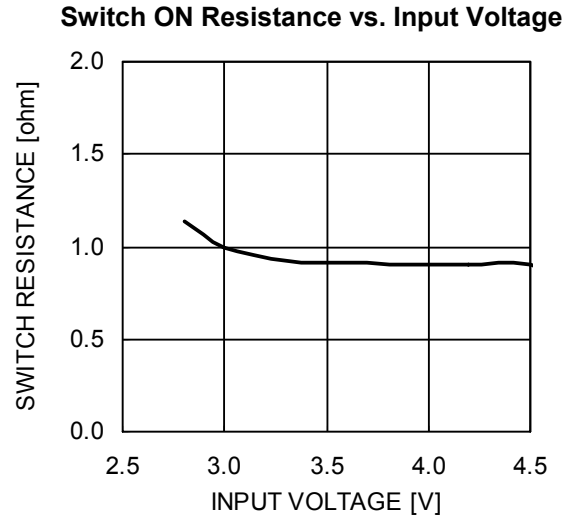
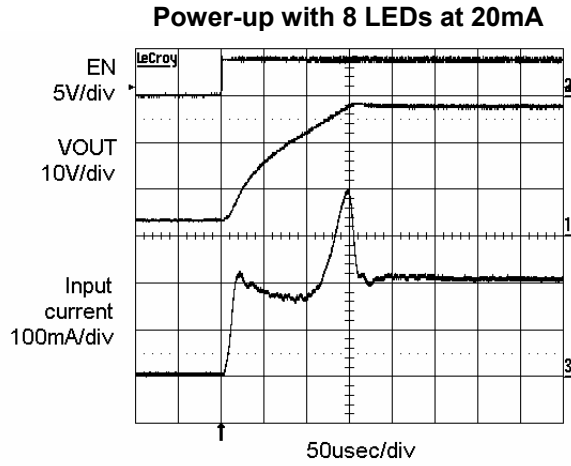

Maximum Output Current vs. Input Voltage

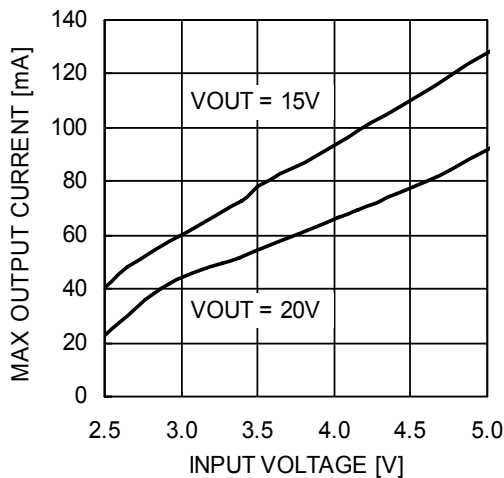

APPLICATION INFORMATION

External Component Selection

Capacitors

The CAT4237 only requires small ceramic capacitors of 4.7µF on the input and 0.22µF on the output. Under normal condition, a 4.7µF input capacitor is sufficient. For applications with higher output power, a larger input capacitor of 10µF may be appropriate. X5R and X7R capacitor types are ideal due to their stability across temperature range.

Inductor

A 33µH inductor is recommended for most of the CAT4237 applications. In cases where the efficiency is critical, inductances with lower series resistance are preferred. Inductors with current rating of 300mA or higher are recommended for most applications. Sumida CDRH3D16-330 33µH inductor has a rated current of 320mA and a series resistance (D.C.R.) of 520mΩ typical.

Schottky Diode

The current rating of the Schottky diode must exceed the peak current flowing through it. The Schottky diode performance is rated in terms of its forward voltage at a given current. In order to achieve the best

efficiency, this forward voltage should be as low as possible. The response time is also critical since the driver is operating at 1MHz. Central Semiconductor Schottky diode CMDSH05-4 (500mA rated) is recommended for most applications.

LED Current Setting

The LED current is set by the external resistor R₁ connected between the feedback pin (FB) and ground. The formula below gives the relationship between the resistor and the current:

$$R_1 = 0.3V/LED \text{ current}$$

Table 1. Resistor R₁ and LED current

LED current (mA)	R ₁ (Ω)
5	60
10	30
15	20
20	15
25	12
30	10

OPEN LED PROTECTION

In the event of an “Open LED” fault condition, the CAT4237 will continue to boost the output voltage with maximum power until the output voltage reaches approximately 35V. Once the output exceeds this level, the internal circuitry immediately places the device into a very low power mode where the total input power is limited to about 4mW (about 1mA input

current with a 3.6V supply). The SW pin clamps at a voltage below its maximum rating of 60V. There is no need to use an external zener diode between Vout and the FB pin. A 50V rated C₂ capacitor is required to prevent any overvoltage damage in the open LED condition.

Open LED Protection without Zener

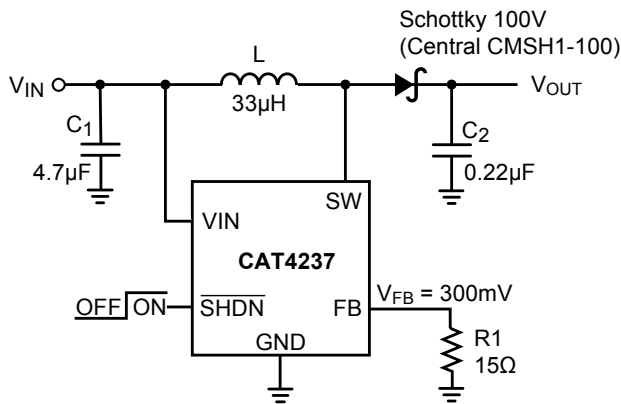

Open LED Switching waveforms without Zener

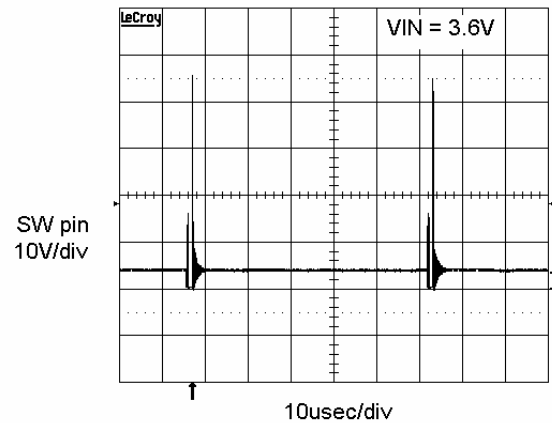

Open LED Supply Current vs. VIN without Zener

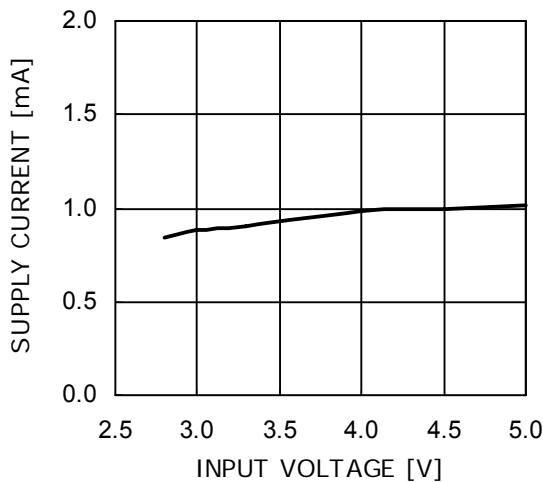

Open LED Output Voltage vs. VIN without Zener

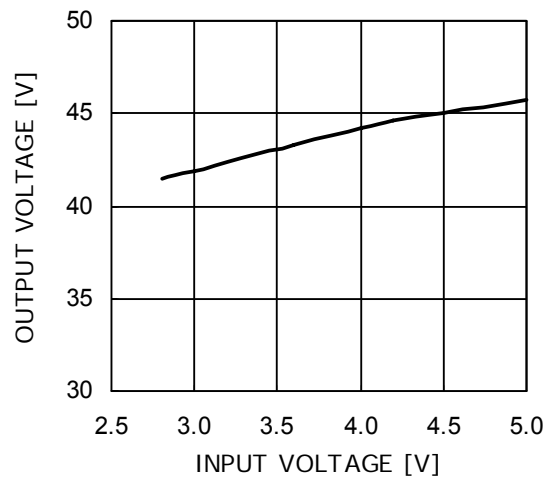

DIMMING CONTROL

There are several methods available to control the LED brightness.

PWM signal on the $\overline{\text{SHDN}}$ Pin

LED brightness dimming can be done by applying a PWM signal to the $\overline{\text{SHDN}}$ input. The LED current is repetitively turned on and off, so that the average current is proportional to the duty cycle. A 100% duty cycle, with $\overline{\text{SHDN}}$ always high, corresponds to the LEDs at nominal current. Figure 1 shows a 1kHz signal with a 50% duty cycle applied to the $\overline{\text{SHDN}}$ pin. The recommended PWM frequency range is from 100Hz to 2kHz.

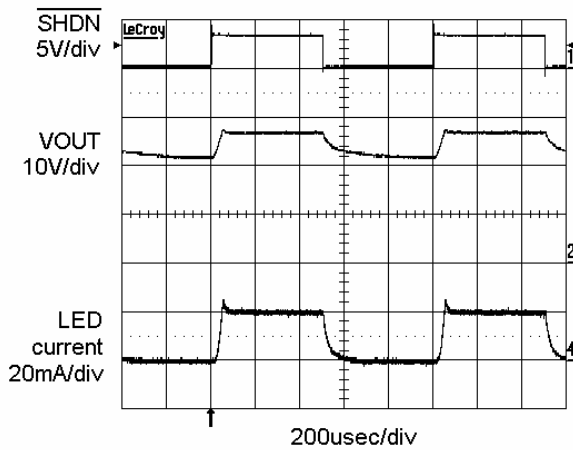

Figure 1. Switching Waveform with 1kHz PWM on $\overline{\text{SHDN}}$

Filtered PWM Signal

A filtered PWM signal used as a variable DC voltage can control the LED current. Figure 2 shows the PWM control circuitry connected to the CAT4237 FB pin. The PWM signal has a voltage swing of 0V to 2.5V. The LED current can be dimmed within a range from 0mA to 20mA. The PWM signal frequency can vary from very low frequency up to 100kHz.

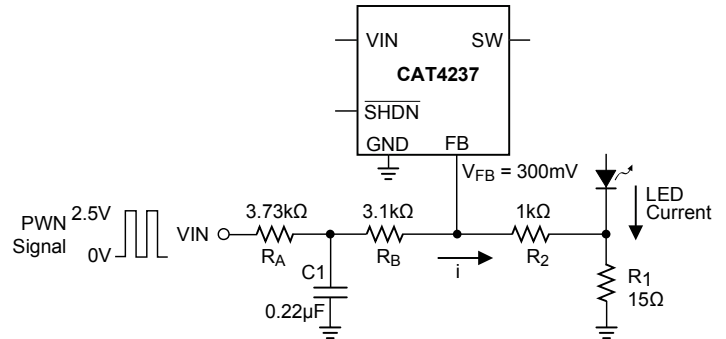
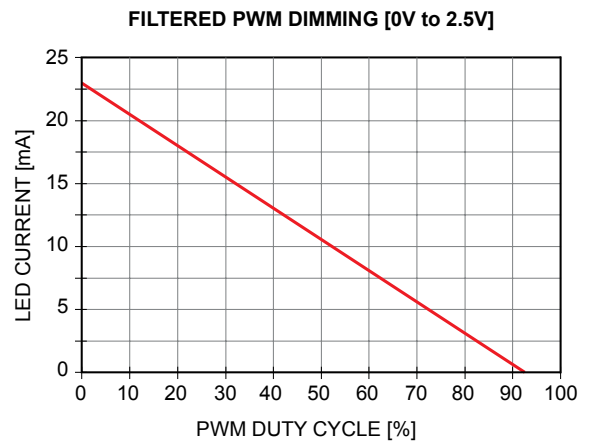

Figure 2. Circuit for Filtered PWM Signal

A PWM signal at 0V DC, or a 0% duty cycle, results in a max LED current of about 22mA. A PWM signal with a 93% duty cycle or more, results in an LED current of 0mA.



BOARD LAYOUT

The CAT4237 is a high-frequency switching regulator. The traces that carry the high-frequency switching current have to be carefully layout on the board in order to minimize EMI, ripple and noise in general. The thicker lines on Figure 3 show the switching current path. All these traces have to be short and wide enough to minimize the parasitic inductance and resistance. The loop shown on Figure 3 corresponds to the current path when the CAT4237 internal switch is closed. On Figure 4 is shown the current loop, when the CAT4237 switch is open. Both loop areas should be as small as possible.

Capacitor C_1 has to be placed as close as possible to the V_{IN} pin and GND. The capacitor C_2 has to be connected separately to the top LED anode. A ground plane under the CAT4237 allows for direct connection of the capacitors to ground. The resistor R_1 must be connected directly to the GND pin of the CAT4237 and not shared with the switching current loops and any other components.

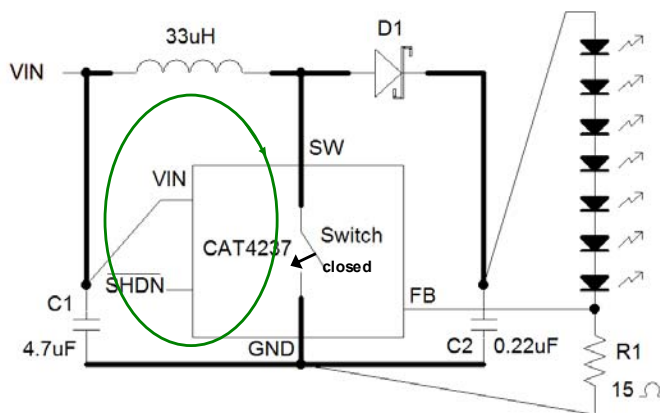

Figure 3. Closed-switch Current Loop

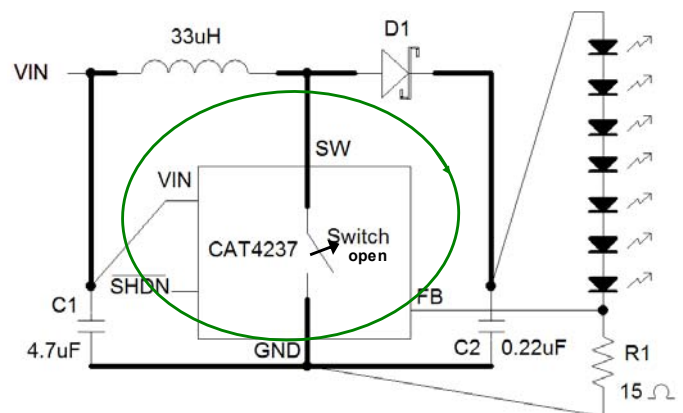
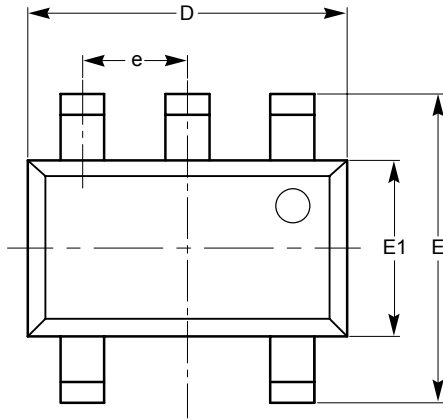

Figure 4. Open-switch Current Loop

PACKAGE OUTLINE DRAWING

TSOT-23 5-Lead (TD) ⁽¹⁾⁽²⁾



TOP VIEW

SYMBOL	MIN	NOM	MAX
A			1.00
A1	0.01	0.05	0.10
A2	0.80	0.87	0.90
b	0.30		0.45
c	0.12	0.15	0.20
D	2.90 BSC		
E	2.80 BSC		
E1	1.60 BSC		
e	0.95 TYP		
L	0.30	0.40	0.50
L1	0.60 REF		
L2	0.25 BSC		
θ	0°		8°

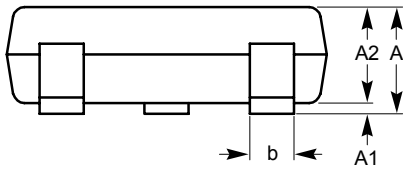

SIDE VIEW

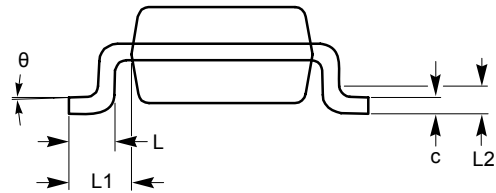

END VIEW

For current Tape and Reel information, download the PDF file from:
<http://www.catsemi.com/documents/tapeandreel.pdf>.

Notes:

- (1) All dimensions are in millimeters. Angles in degrees.
- (2) Complies with JEDEC standard MO-229.

EXAMPLE OF ORDERING INFORMATION

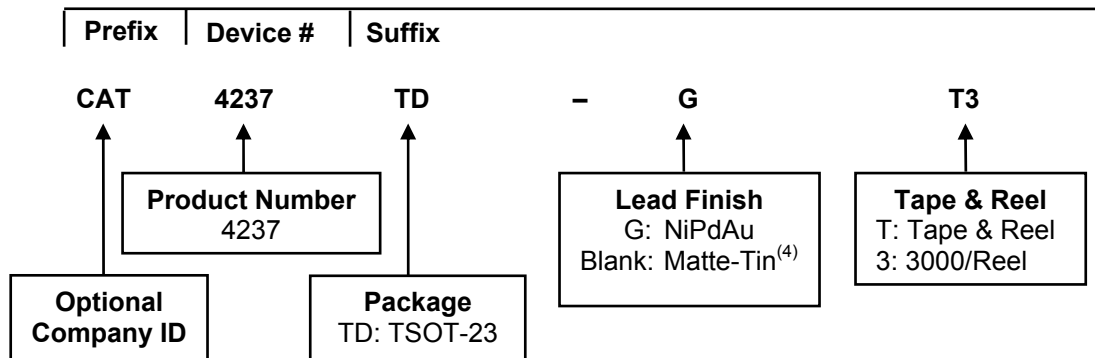

Notes:

- (1) All packages are RoHS-compliant (Lead-free, Halogen-free).
- (2) The standard lead finish is NiPdAu.
- (3) The device used in the above example is a CAT4237TD-GT3 (TSOT-23, NiPdAu Plated Finish, Tape & Reel 3000).
- (4) For Matte-Tin package option, please contact your nearest ON Semiconductor Sales office.

REVISION HISTORY

Date	Rev.	Description
13-Dec-05	00	Initial Issue
31-Jan-07	A	Update Absolute Maximum Ratings Update Recommended Operating Conditions Change document number from 25094 to 5013, Rev. A
07-Jan-08	B	Add NiPdAu lead finish Add Extended Temperature range Update Package Outline Drawing Add Example of Ordering Information Add "MD-" to Document Number
19-Nov-08	C	Change logo and fine print to ON Semiconductor

ON Semiconductor and  are registered trademarks of Semiconductor Components Industries, LLC (SCILLC). SCILLC reserves the right to make changes without further notice to any products herein. SCILLC makes no warranty, representation or guarantee regarding the suitability of its products for any particular purpose, nor does SCILLC assume any liability arising out of the application or use of any product or circuit, and specifically disclaims any and all liability, including without limitation special, consequential or incidental damages. "Typical" parameters which may be provided in SCILLC data sheets and/or specifications can and do vary in different applications and actual performance may vary over time. All operating parameters, including "Typicals" must be validated for each customer application by customer's technical experts. SCILLC does not convey any license under its patent rights nor the rights of others. SCILLC products are not designed, intended, or authorized for use as components in systems intended for surgical implant into the body, or other applications intended to support or sustain life, or for any other application in which the failure of the SCILLC product could create a situation where personal injury or death may occur. Should Buyer purchase or use SCILLC products for any such unintended or unauthorized application, Buyer shall indemnify and hold SCILLC and its officers, employees, subsidiaries, affiliates, and distributors harmless against all claims, costs, damages, and expenses, and reasonable attorney fees arising out of, directly or indirectly, any claim of personal injury or death associated with such unintended or unauthorized use, even if such claim alleges that SCILLC was negligent regarding the design or manufacture of the part. SCILLC is an Equal Opportunity/Affirmative Action Employer. This literature is subject to all applicable copyright laws and is not for resale in any manner.

PUBLICATION ORDERING INFORMATION

LITERATURE FULFILLMENT:

Literature Distribution Center for ON Semiconductor
P.O. Box 5163, Denver, Colorado 80217 USA
Phone: 303-675-2175 or 800-344-3860 Toll Free USA/Canada
Fax: 303-675-2176 or 800-344-3867 Toll Free USA/Canada
Email: orderlit@onsemi.com

N. American Technical Support: 800-282-9855 Toll Free
USA/Canada
Europe, Middle East and Africa Technical Support:
Phone: 421 33 790 2910
Japan Customer Focus Center:
Phone: 81-3-5773-3850

ON Semiconductor Website: www.onsemi.com

Order Literature: <http://www.onsemi.com/orderlit>

For additional information, please contact your local Sales Representative