

**CONNECTOR
 DESIGNATORS**
A-F-H-L-S
**ROTATABLE
 COUPLING**

**TYPE C OVERALL
 SHIELD TERMINATION**

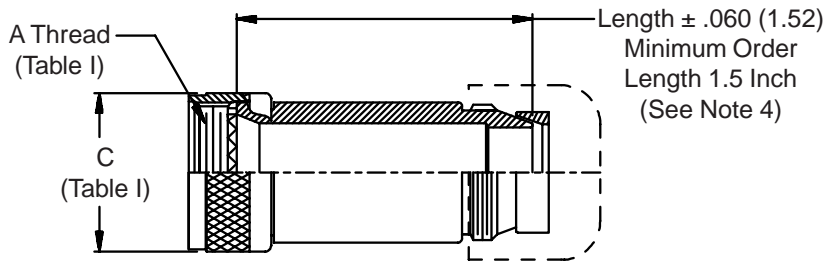

**STYLE 2
 (STRAIGHT
 See Note 1)**

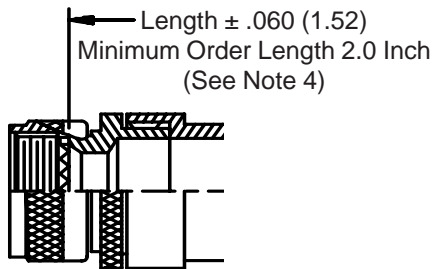
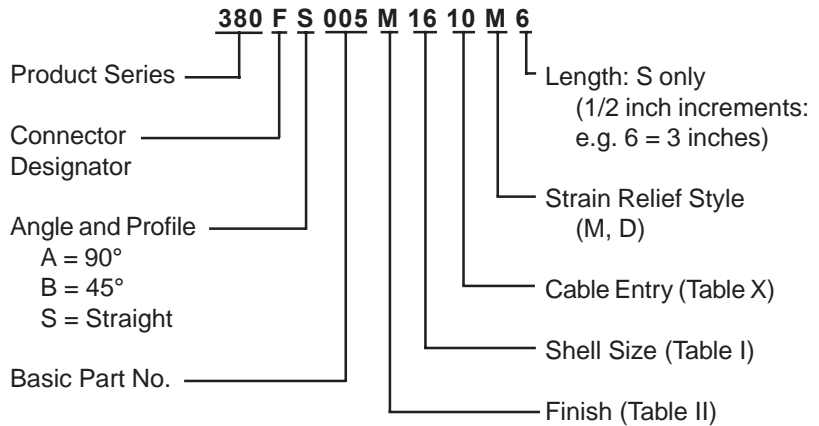
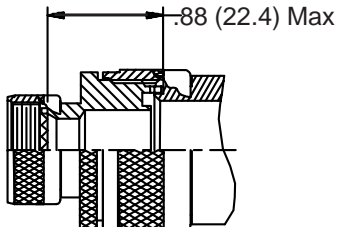

**STYLE 2
 (45° & 90°
 See Note 1)**

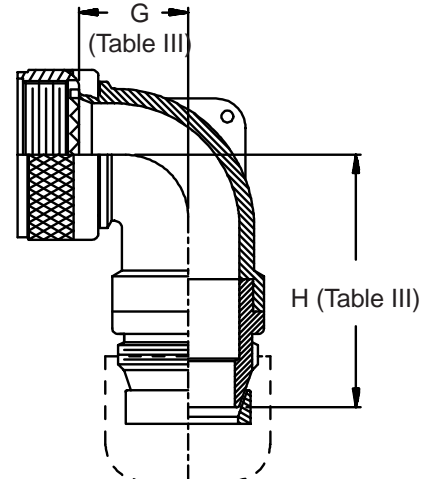
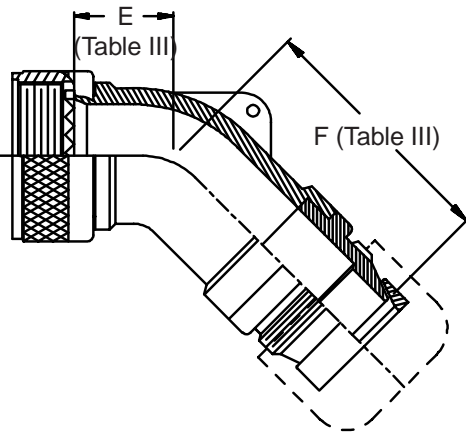

**STYLE M
 Medium Duty - Dash No. 01-04
 (Table X)**

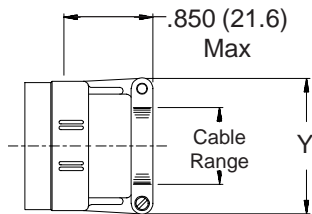

**STYLE M
 Medium Duty - Dash No. 10-28
 (Table X)**

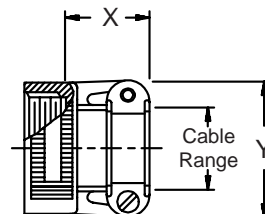

**STYLE D
 Medium Duty
 (Table X)**

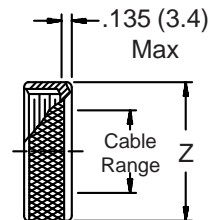

380-005
EMI/RFI Non-Environmental Backshell
Heavy-Duty with Strain Relief
Type C - Rotatable Coupling - Low Profile



See inside back cover fold-out or pages 13 and 14 for Unabridged Tables I and II.

TABLE III: ELBOW DIMENSIONS									
Shell Size		E		F		G		H	
Conn. Desig.	H	Max		Max		Max		Max	
A-F-L-S									
08	09	.457	(11.6)	1.848	(46.9)	.500	(12.7)	1.858	(47.2)
10	11	.520	(13.2)	1.908	(48.5)	.595	(15.1)	1.978	(50.2)
12	13	.582	(14.8)	1.968	(50.0)	.610	(15.5)	1.998	(50.7)
14	15	.645	(16.4)	2.347	(59.6)	.700	(17.8)	2.357	(59.9)
16	17	.738	(18.7)	2.457	(62.4)	.885	(22.5)	2.447	(62.2)
18	19	.926	(23.5)	2.647	(67.2)	.975	(24.8)	2.617	(66.5)
20	21	.926	(23.5)	2.647	(67.2)	.975	(24.8)	2.617	(66.5)
22	23	1.020	(25.9)	2.922	(74.2)	1.125	(28.6)	2.852	(72.4)
24	25	1.020	(25.9)	2.922	(74.2)	1.125	(28.6)	2.852	(72.4)
28		1.145	(29.1)	2.972	(75.5)	1.225	(31.1)	3.022	(76.8)
32		1.207	(30.7)	3.072	(78.0)	1.575	(40.0)	3.272	(83.1)
36		1.238	(31.4)	3.162	(80.3)	1.775	(45.1)	3.272	(83.1)

TABLE X: CABLE ENTRY						
Dash No.	X Max	Y Max	Z Max	Cable Range		
				Min	Max	
01	.850 (21.6)	.781 (19.8)	.593 (15.1)	.062 (1.6)	.125 (3.2)	
02	.850 (21.6)	.968 (24.6)	.718 (18.2)	.125 (3.2)	.250 (6.4)	
03	.850 (21.6)	1.046 (26.6)	.843 (21.4)	.250 (6.4)	.375 (9.5)	
04	.850 (21.6)	1.156 (29.4)	.968 (24.6)	.375 (9.5)	.500 (12.7)	
10	.760 (19.3)	1.281 (32.5)	1.192 (30.3)	.375 (9.5)	.625 (15.9)	
12	.760 (19.3)	1.500 (38.1)	1.380 (35.1)	.438 (11.1)	.750 (19.1)	
16	1.073 (27.3)	1.719 (43.7)	1.535 (39.0)	.562 (14.3)	.938 (23.8)	
20	1.323 (33.6)	2.062 (52.4)	1.848 (46.9)	.750 (19.1)	1.250 (31.8)	
24	1.323 (33.6)	2.312 (58.7)	2.255 (57.3)	.875 (22.2)	1.375 (34.9)	
28	1.572 (39.9)	2.719 (69.1)	2.505 (63.6)	1.125 (28.6)	1.625 (41.3)	

- When maximum cable entry (page 21) is exceeded, Style 2 will be supplied.
Dimensions E, F, G and H will not apply. Please consult factory.
- Metric dimensions (mm) are indicated in parentheses.
- Cable range is defined as the accommodations range for the wire bundle or cable.
Dimensions shown are not intended for inspection criteria.
- Consult factory for shorter lengths on straight backshells.

TABLE II: STANDARD FINISHES	
GLENAIR SYMBOL	FINISH
B	Cadmium Plate, Olive Drab
M	Electroless Nickel
NF	Cadmium Plate, Olive Drab Over Electroless Nickel
See Inside Back Cover for Additional Finish Options	