

A

CONNECTOR DESIGNATOR:	
A	MIL-DTL-5015, -26482 Series II, and -83723 Series I and III
F	MIL-DTL-38999 Series I, II
L	MIL-DTL-38999 Series 1.5 (JN1003)
H	MIL-DTL-38999 Series III and IV
G	MIL-DTL-28840
U	DG123 and DG123A
SELF-LOCKING	
ROTATABLE COUPLING	
STANDARD PROFILE	

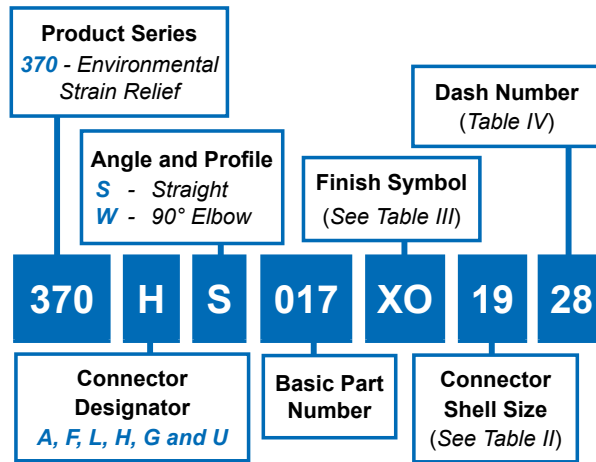

US PATENT 5211576

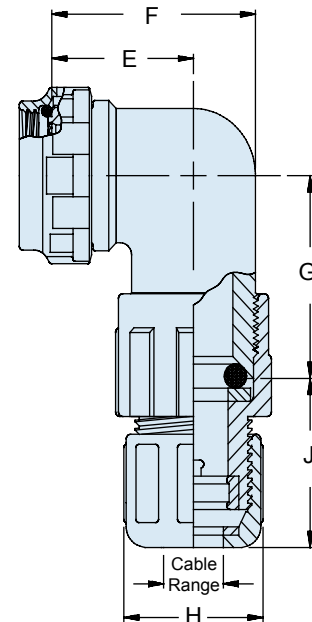
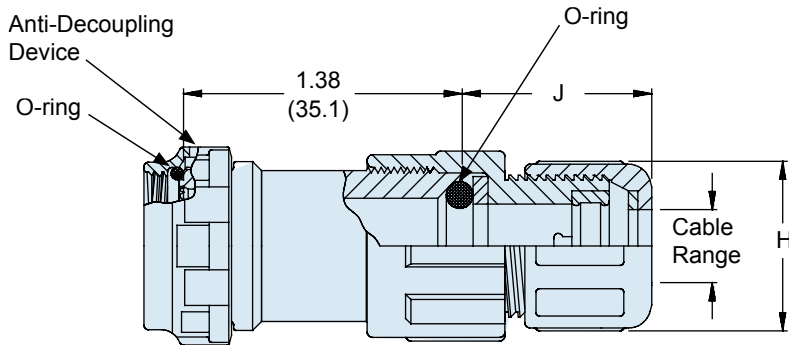

NOTES

1. Coupling nut supplied unplated.
2. See Table I in Intro for front-end dimensional details.

370-017
Composite Cable-Sealing Environmental Backshell
with Self-Locking Rotatable Coupling
and Qwik-Clamp



Composite Backshells

A

TABLE II: CONNECTOR SHELL SIZE ORDER NUMBER

Shell Size For Connector Designator*					E		F		G		Max Entry Dash No.**
A	F/L	H	G	U	± .06 (1.5)	± .09 (2.3)	± .09 (2.3)	± .09 (2.3)	± .09 (2.3)		
08	08	09	-	-	.69 (17.5)	.88 (22.4)	1.06 (26.9)	1.13 (28.7)	1.19 (30.2)	08	
10	10	11	-	08	.75 (19.1)	1.00 (25.4)	1.13 (28.7)	1.19 (30.2)	1.25 (31.8)	12	
12	12	13	11	10	.81 (20.6)	1.13 (28.7)	1.31 (33.3)	1.31 (33.3)	1.34 (34.0)	16	
14	14	15	13	12	.88 (22.4)	1.31 (33.3)	1.38 (35.1)	1.34 (34.0)	1.44 (36.6)	20	
16	16	17	15	14	.94 (23.9)	1.38 (35.1)	1.44 (36.6)	1.44 (36.6)	1.50 (38.1)	24	
18	18	19	17	16	.97 (24.6)	1.44 (36.6)	1.63 (41.4)	1.44 (36.6)	1.56 (39.6)	28	
20	20	21	19	18	1.06 (26.9)	1.63 (41.4)	1.66 (42.2)	1.50 (38.1)	1.66 (42.2)	32	
22	22	23	-	20	1.13 (28.7)	1.75 (44.5)	1.66 (42.2)	1.56 (39.6)	1.75 (44.5)	36	
24	24	25	23	22	1.19 (30.2)	1.88 (47.8)	1.66 (42.2)	1.66 (42.2)	1.88 (47.8)	40	
28	-	-	25	24	1.34 (34.0)	2.13 (54.1)	1.66 (42.2)	1.66 (42.2)	2.13 (54.1)	44	

**Consult factory for additional entry sizes available.

TABLE III: FINISH

Symbol	Finish Description
XB	No Plating - Black Color (Non-Conductive Finish)
XM	2000 Hour Corrosion Resistant Electroless Nickel
XMT	2000 Hour Corrosion Resistant Ni-PTFE, Nickel-Fluorocarbon Polymer. 1000 Hour Grey™
XO	No Plating - Brown Color (Non-Conductive Finish)
XW	2000 Hour Corrosion Resistant Cadmium/Olive Drab over Electroless Nickel

TABLE IV: CABLE ENTRY

Dash No.	H (Max)	J (Max)	Cable Range	
			Minimum	Maximum
08	.72 (18.3)	.87 (22.1)	.13 (3.3)	.25 (6.4)
12	.91 (23.1)	1.01 (25.7)	.22 (5.6)	.38 (9.7)
16	1.09 (27.7)	1.11 (28.2)	.34 (8.6)	.50 (12.7)
20	1.22 (31.0)	1.11 (28.2)	.47 (11.9)	.63 (15.9)
24	1.34 (34.0)	1.11 (28.2)	.60 (15.0)	.75 (19.1)
28	1.53 (38.9)	1.26 (32.0)	.72 (18.3)	.88 (22.2)
32	1.72 (43.7)	1.41 (35.8)	.84 (21.3)	1.00 (25.4)
36	1.85 (47.0)	1.41 (35.8)	.97 (24.6)	1.13 (28.6)
40	1.97 (50.0)	1.41 (35.8)	1.09 (27.7)	1.25 (31.8)
44	2.09 (53.1)	1.53 (38.9)	1.22 (31.0)	1.38 (34.9)