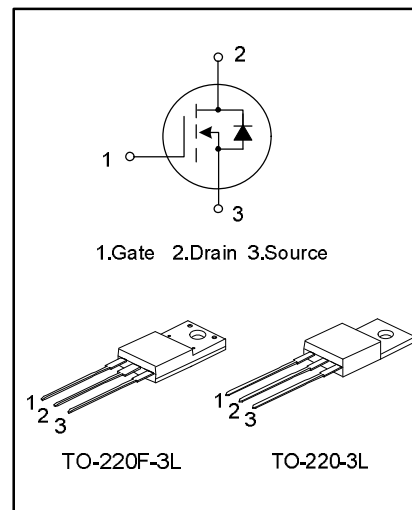

5A, 600V N-CHANNEL MOSFET
GENERAL DESCRIPTION

SVD5N60AT/F is an N-channel enhancement mode power MOS field effect transistor which is produced using Silan proprietary S-Rin™ structure DMOS technology. The improved planar stripe cell and the improved guarding ring terminal have been especially tailored to minimize on-state resistance, provide superior switching performance, and withstand high energy pulse in the avalanche and commutation mode.

These devices are widely used in AC-DC power suppliers, DC-DC converters and H-bridge PWM motor drivers.

FEATURES

- * 5A,600V, $R_{DS(on)}$ (typ) =2.0 Ω @ V_{GS} =10V
- * Low gate charge
- * Low Crss
- * Fast switching
- * Improved dv/dt capability

ORDERING SPECIFICATIONS

Part No.	Package	Marking	Shipping
SVD5N60AT	TO-220-3L	SVD5N60AT	50Unit/Tube
SVD5N60AF	TO-220F-3L	SVD5N60AF	50Unit/Tube

ABSOLUTE MAXIMUM RATINGS (Tc=25°C unless otherwise noted)

Parameter	Symbol	SVD5N60AT	SVD5N60AF	Unit
Drain-Source Voltage	V _{DS}	600		V
Gate-Source Voltage	V _{GS}	±30		V
Drain Current	I _D	5.0		A
Power Dissipation(Tc=25°C) -Derate above 25°C	P _D	100	33	W
		0.8	0.26	
Single Pulsed Avalanche Energy (Note 1)	E _{AS}	330		mJ
Repetitive Avalanche Energy (Note 2)	E _{AR}	7.3		mJ
Operation Junction Temperature	T _J	-55~+150		°C
Storage Temperature	T _{stg}	-55~+150		°C

THERMAL CHARACTERISTICS

Parameter	Symbol	SVD5N60AT	SVD5N60AF	Unit
Thermal Resistance, Junction-to-Case	R _{θJC}	1.25	3.79	°C/W
Thermal Resistance, Junction-to-Ambient	R _{θJA}	62.5	62.5	°C/W

ELECTRICAL CHARACTERISTICS (T_c=25°C unless otherwise noted)

Parameter	Symbol	Test conditions	Min.	Typ.	Max.	Unit
Drain -Source Breakdown Voltage	BVDSS	V _{GS} =0V, I _D =250μA	600	--	--	V
Drain-Source Leakage Current	I _{DSS}	V _{DS} =600V, V _{GS} =0V	--	--	10	μA
Gate-Source Leakage Current	I _{GSS}	V _{GS} =±30V, V _{DS} =0V	--	--	±100	nA
Gate Threshold Voltage	V _{GS(th)}	V _{GS} = V _{DS} , I _D =250μA	2.0	--	4.0	V
Static Drain- Source On State Resistance	R _{DS(on)}	V _{GS} =10V, I _D =2A	--	2.0	2.4	Ω
Input Capacitance	C _{iss}	V _{DS} =25V, V _{GS} =0V, f=1.0MHZ	--	672	--	pF
Output Capacitance	C _{oss}		--	66	--	
Reverse Transfer Capacitance	C _{rss}		--	4.7	--	
Turn-on Delay Time	t _{d(on)}	V _{DD} =300V, I _D =4.4A, R _G =25Ω (Note 3,4)	--	27	--	ns
Turn-on Rise Time	t _r		--	19	--	
Turn-off Delay Time	t _{d(off)}		--	160	--	
Turn-off Fall Time	t _f		--	22	--	
Total Gate Charge	Q _g	V _{DS} =480V, I _D =4.4A, V _{GS} =10V (Note 3,4)	--	19.8	--	nC
Gate-Source Charge	Q _{gs}		--	4	--	
Gate-Drain Charge	Q _{gd}		--	7.2	--	

SOURCE-DRAIN DIODE RATINGS AND CHARACTERISTICS

Parameter	Symbol	Test conditions	Min.	Typ.	Max.	Unit
Continuous Source Current	I _S	Integral Reverse P-N Junction Diode in the MOSFET	--	--	5.0	A
Pulsed Source Current	I _{SM}		--	--	16	
Diode Forward Voltage	V _{SD}	I _S =5.0A, V _{GS} =0V	--	--	1.4	V
Reverse Recovery Time	T _{rr}	I _S =5.0A, V _{GS} =0V,	--	300	--	ns
Reverse Recovery Charge	Q _{rr}	dI _F /dt=100A/μs (Note 3)	--	2.2	--	μC

Notes:

- L=30mH, I_{AS}=4.4A, V_{DD}=85V, R_G=25Ω, starting T_J=25°C;
- Repetitive Rating: Pulse width limited by maximum junction temperature;
- Pulse Test: Pulse width ≤300μs, Duty cycle ≤2%;
- Essentially independent of operating temperature.

NOMENCLATURE

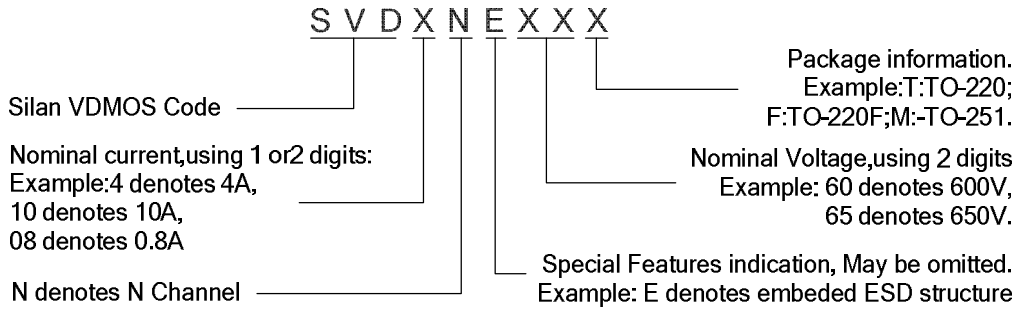

TYPICAL CHARACTERISTICS

Figure 1. On-Region Characteristics

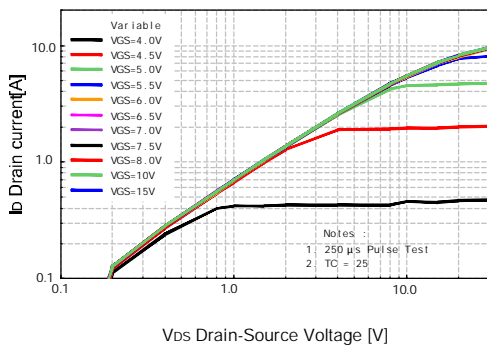

Figure 2. Transfer Characteristics

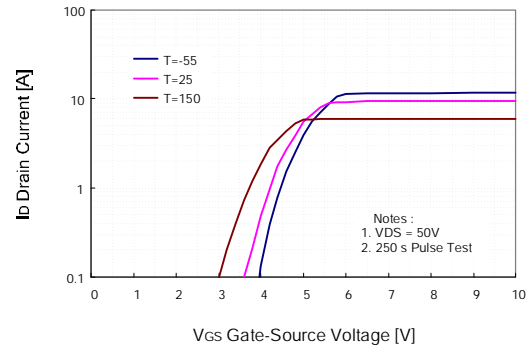

Figure 3. On-Resistance Variation vs. Drain Current and Gate Voltage

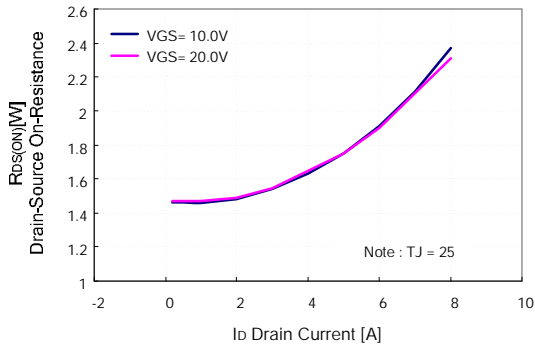
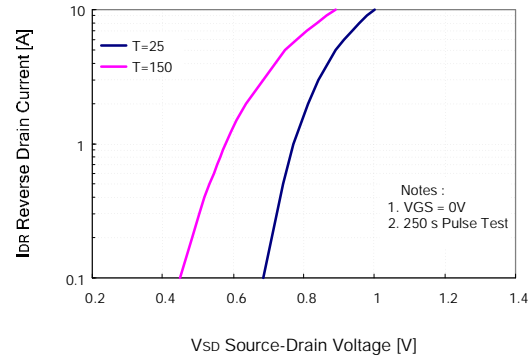

Figure 4. Body Diode Forward Voltage Variation vs. Source Current and Temperature



TYPICAL CHARACTERISTICS (continued)

Figure 5. Capacitance Characteristics

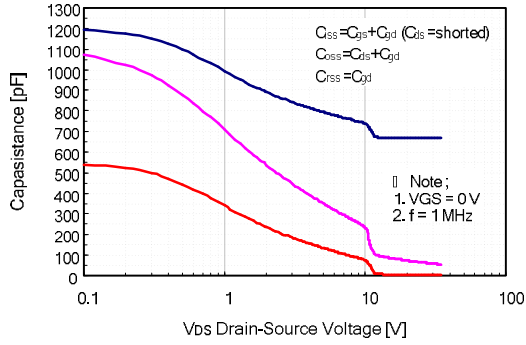

Figure 6. Gate Charge Characteristics

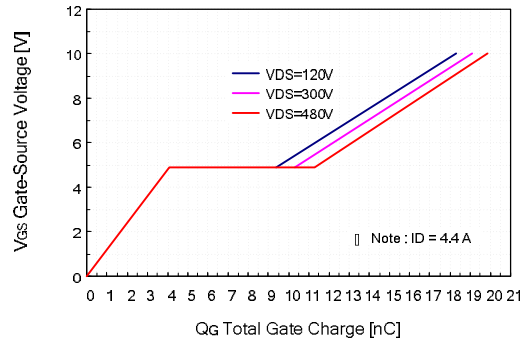

Figure 7. Breakdown Voltage Variation vs. Temperature

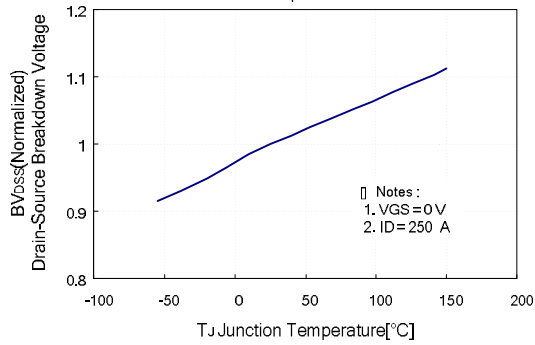
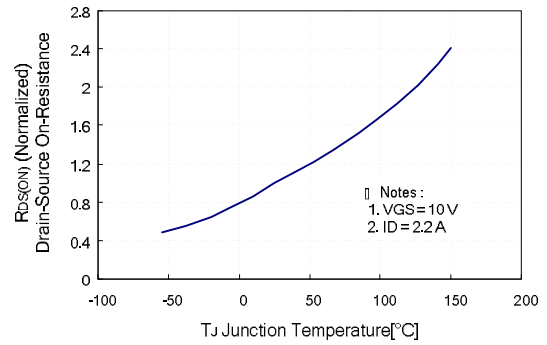
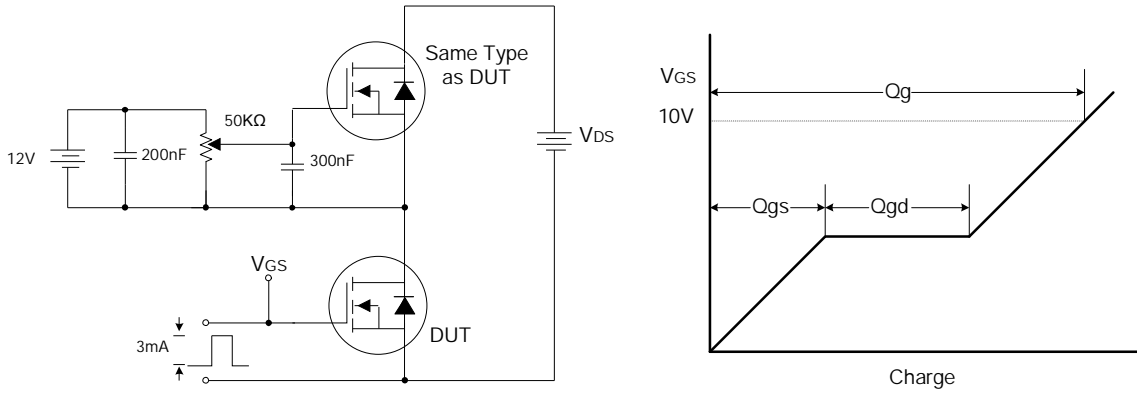

Figure 8. On-resistance Variation vs Temperature



TYPICAL TEST CIRCUIT

Gate Charge Test Circuit & Waveform



Resistive Switching Test Circuit & Waveform

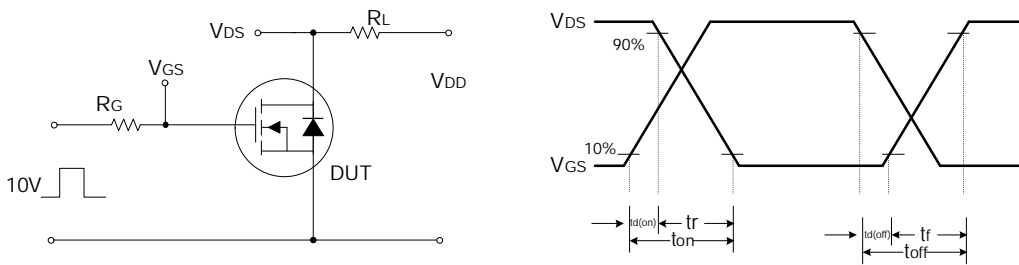

Unclamped Inductive Switching Test Circuit & Waveform

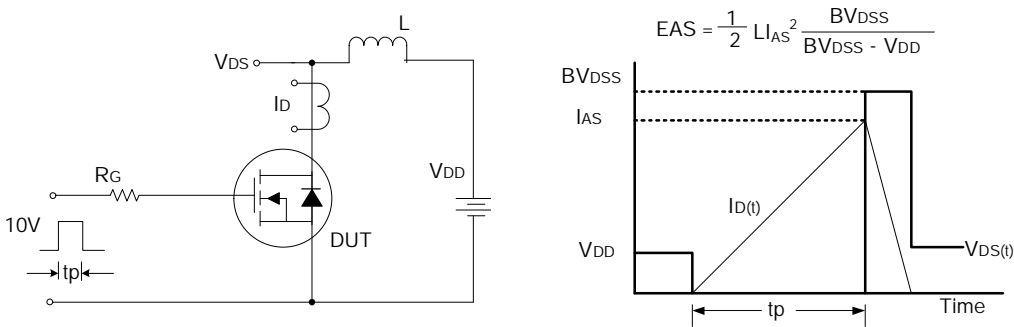

PACKAGE OUTLINE

TO-220-3L(One)

UNIT: mm

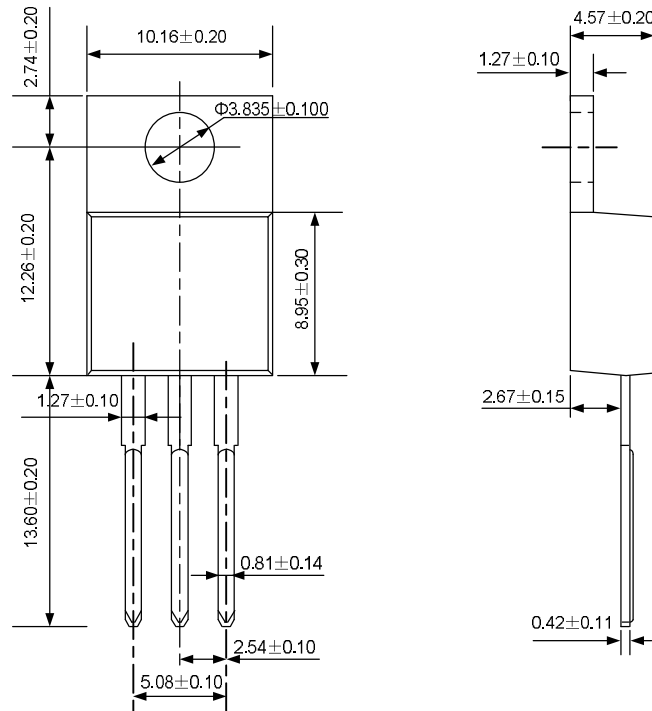

TO-220-3L (Two)

UNIT: mm

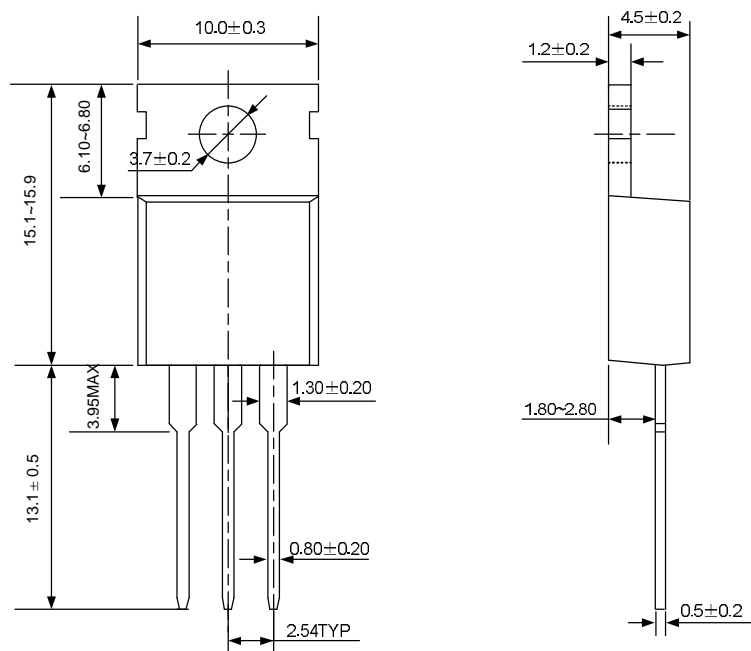

PACKAGE OUTLINE (continued)

