

isc Silicon PNP Power Transistor

MJW21191

DESCRIPTION

- DC Current Gain
- High Area of Safe Operation

APPLICATIONS

- Designed for power audio output, or high power drivers in audio amplifiers.

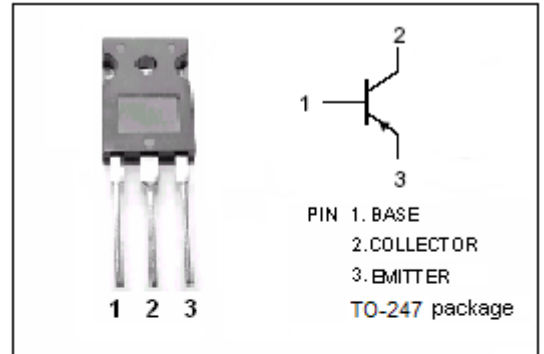

ABSOLUTE MAXIMUM RATINGS(Ta=25°C)

SYMBOL	PARAMETER	VALUE	UNIT
V <sub>CBO</sub>	Collector-Emitter Voltage	-150	V
V <sub>CEO</sub>	Collector-Emitter Voltage	-150	V
V <sub>EBO</sub>	Emitter-Base Voltage	-5	V
I <sub>C</sub>	Collector Current-Continuous	-8	A
I <sub>CM</sub>	Collector Current-Pulsed	-16	A
I <sub>B</sub>	Base Current-Continuous	-2	A
P <sub>D</sub>	Total Power Dissipation (T <sub>C</sub> =25°C)	100	W
T <sub>j</sub>	Junction Temperature	150	°C
T <sub>stg</sub>	Storage Temperature	-65~150	°C

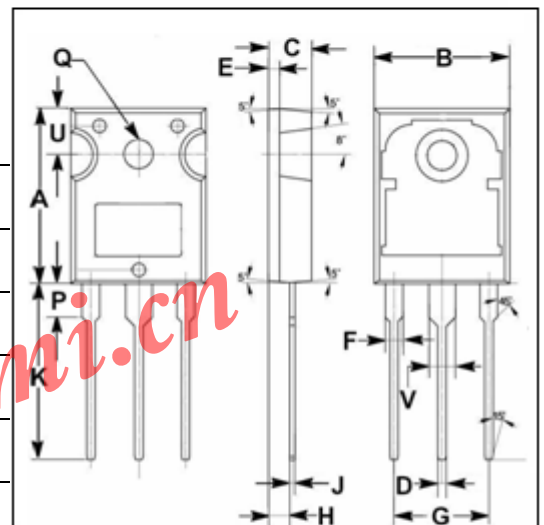

DIM	mm	
	MIN	MAX
A	19.80	20.20
B	15.40	15.80
C	4.90	5.10
D	0.90	1.10
E	1.40	1.60
F	1.90	2.10
G	10.80	11.00
H	2.40	2.60
J	0.50	0.70
K	19.50	20.50
P	3.90	4.10
Q	3.30	3.50
U	5.20	5.40
V	2.90	3.10

THERMAL CHARACTERISTICS

SYMBOL	PARAMETER	VALUE	UNIT
R <sub>th j-c</sub>	ThermalResistance Junction To Case	0.65	°C/W

## isc Silicon PNP Power Transistor

MJW21191

## ELECTRICAL CHARACTERISTICS

T<sub>j</sub>=25°C unless otherwise specified

SYMBOL	PARAMETER	CONDITIONS	MIN	TYP.	MAX	UNIT
V <sub>CEO(SUS)</sub>	Collector-Emitter Sustaining Voltage	I <sub>C</sub> =-10mA; I <sub>B</sub> =0	-150			V
V <sub>CE(sat)-1</sub>	Collector-Emitter Saturation Voltage	I <sub>C</sub> =-4A ; I <sub>B</sub> =-0.4A			-1.0	V
V <sub>CE(sat)-2</sub>	Collector-Emitter Saturation Voltage	I <sub>C</sub> =-8A ; I <sub>B</sub> =-1.6A			-2.0	V
V <sub>BE(on)</sub>	Base-Emitter On Voltage	I <sub>C</sub> =-4A ; V <sub>CE</sub> =-2V			-2	V
I <sub>CEs</sub>	Collector Cutoff Current	V <sub>CE</sub> = -250V; I <sub>E</sub> =0			-10	μ A
I <sub>EBO</sub>	Emitter Cutoff Current	V <sub>EB</sub> =-5V; I <sub>C</sub> =0			-10	μ A
h <sub>FE-1</sub>	DC Current Gain	I <sub>C</sub> =-4A; V <sub>CE</sub> =-2V		15	100	
h <sub>FE-2</sub>	DC Current Gain	I <sub>C</sub> =-8A; V <sub>CE</sub> =-2V	5			
f <sub>T</sub>	Current Gain-Bandwidth Product	I <sub>C</sub> =-1A ; V <sub>CE</sub> =-10V; f <sub>test</sub> =1MHz	4			MHz

www.iscsemi.cn