

FSA2258 Low-Voltage, Dual-SPDT (0.8Ω) Analog Switch with 16kV ESD

Features

- 0.8Ω Typical On Resistance (R_{ON}) for +3.0V Supply
- 0.40Ω Maximum R_{ON} Flatness for +3.0V Supply
- -3db Bandwidth: > 50MHz
- Low I_{CCT} Current Over an Expanded Control Input Range
- Packaged in 10-Lead MicroPak™ (1.6 x 2.1mm)
- Power-Off Protection on Common Ports
- Broad V_{CC} Operating Range: 1.65V to 4.30V
- HBM JEDEC: JESD22-A114
 - I/O to GND: 9kV
 - Power to GND: 16kV

Applications

- Cell Phone, PDA, Digital Camera, and Notebook
- LCD Monitor, TV, and Set-Top Box

Description

The FSA2258 is a high-performance, dual, Single Pole Double Throw (SPDT) analog switch that features low R_{ON} of 0.8Ω (typical) at 3.0V V_{CC} . The FSA2258 operates over a wide V_{CC} range of 1.65V to 4.3V and is designed for break-before-make operation. The select input is TTL-level compatible.

The FSA2258 features very low quiescent current even when the control voltage is lower than the V_{CC} supply. This feature suits mobile handset applications by allowing direct interface with baseband processor general-purpose I/Os with minimal battery consumption.

IMPORTANT NOTE:

For additional information, please contact analogswitch@fairchildsemi.com.

Ordering Information

Part Number	Top Mark	Operating Temperature Range	 Eco Status	Package
FSA2258L10X	JS	-40 to +85°C	Green	10-Lead MicroPak™ 1.6 x 2.1mm, JEDEC MO-255B

 For Fairchild's definition of Eco Status, please visit: http://www.fairchildsemi.com/company/green/rohs_green.html.

Analog Symbol

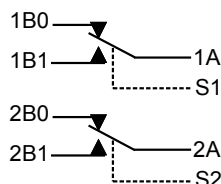

Figure 1. FSA2258

Pin Configuration

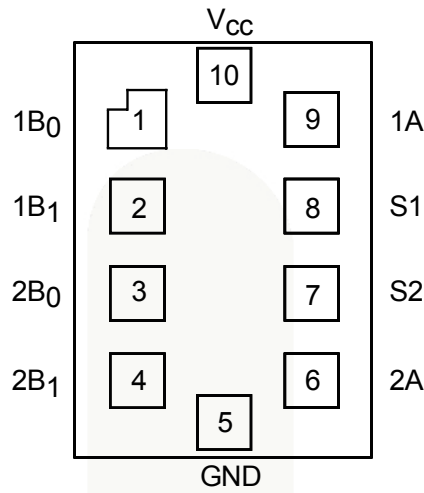

Figure 2. 10-Lead MicroPak™ (Top-Through View)

Pin Descriptions

Pin #	Name	Description
1	1B ₀	Data Ports
2	1B ₁	Data Ports
3	2B ₀	Data Ports
4	2B ₁	Data Ports
5	GND	Ground
6	2A	Data Ports
7	S2	Switch Select Pins
8	S1	Switch Select Pins
9	1A	Data Ports
10	V _{CC}	Supply Voltage

Truth Table

Control Input, S _n	Function
LOW Logic Level	nB ₀ connected to nA
HIGH Logic Level	nB ₁ connected to nA

Absolute Maximum Ratings

Stresses exceeding the absolute maximum ratings may damage the device. The device may not function or be operable above the recommended operating conditions and stressing the parts to these levels is not recommended. In addition, extended exposure to stresses above the recommended operating conditions may affect device reliability. The absolute maximum ratings are stress ratings only.

Symbol	Parameter	Min.	Max.	Units	
V _{CC}	Supply Voltage	-0.5	5.5	V	
V _{SW}	Switch I/O Voltage ⁽¹⁾	-0.5	V _{CC} + 0.3	V	
V _{IN}	Control Input Voltage ⁽¹⁾	-0.5	5.5	V	
I _{IK}	Input Clamp Diode Current		-50	mA	
I _{SW}	Switch I/O Current (Continuous)		350	mA	
I _{SWPEAK}	Peak Switch Current (Pulsed at 1ms Duration, <10% Duty Cycle)		500	mA	
T _{STG}	Storage Temperature Range	-65	+150	°C	
T _J	Maximum Junction Temperature		+150	°C	
T _L	Lead Temperature (Soldering, 10 seconds)		+260	°C	
ESD	Human Body Model, JEDEC: JESD22-A114	I/O to GND		9	kV
		Power to GND		16	
		All Other Pins		9	
	Charged Device Model, JEDEC: JESD22-C101		2.0		

Note:

- Input and output negative ratings may be exceeded if input and output diode current ratings are observed.

Recommended Operating Conditions

The Recommended Operating Conditions table defines the conditions for actual device operation. Recommended operating conditions are specified to ensure optimal performance to the datasheet specifications. Fairchild does not recommend exceeding them or designing to Absolute Maximum Ratings.

Symbol	Parameter	Min.	Max.	Units
V _{CC}	Supply Voltage	1.65	4.30	V
V _{IN}	Control Input Voltage	0	V _{CC}	V
V _{SW}	Switch I/O Voltage	0	4.3	V
T _A	Operating Temperature	-40	+85	°C

DC Electrical Characteristics

All typical values are at 25°C unless otherwise specified.

Symbol	Parameter	Conditions	V _{CC} (V)	T _A =+25°C			T _A =-40 to +85°C		Unit
				Min.	Typ.	Max.	Min.	Max.	
V _{IH}	Control Input Voltage HIGH		3.60 to 4.30				1.7		V
			2.70 to 3.60				1.5		
			2.30 to 2.70				1.4		
			1.65 to 1.95				0.9		
V _{IL}	Control Input Voltage LOW		3.60 to 4.30					0.7	V
			2.70 to 3.60					0.5	
			2.30 to 2.70					0.4	
			1.65 to 1.95					0.4	
I _{IN}	Control Input Leakage (S1,S2)	V _{IN} =0 to V _{CC}	1.65 to 4.30				-0.5	0.5	μA
I _{NO(OFF)} , I _{NC(OFF)}	Off Leakage Current of Port nB0 and nB1	nA=0.3V, V _{CC} =0.3V nB0 or nB1=V _{CC} -0.3V, 0.3V, or Floating Figure 4	1.95 to 4.30	-10		10	-50	50	nA
I _{A(ON)}	On Leakage Current of Port nA	nA=0.3V, V _{CC} =0.3V nB0 or nB1=V _{CC} -0.3V, 0.3V, or Floating Figure 5	1.95 to 4.30	-20		20	-100	100	nA
I _{OFF}	Power-Off Leakage Current (Common Port Only 1A, 2A)	Common Port (1A, 2A), V _{IN} =0V to 4.3V, V _{CC} =0V nB0, nB1=Floating	0					±1	μA
R _{ON}	Switch On Resistance ^(2,5)	I _{ON} =100mA, nB0 or nB1=0.7V, 3.6V Figure 3	4.30		0.5			1.0	Ω
		I _{ON} =100mA, nB0 or nB1=0.7V, 2.3V Figure 3	3.00		0.8			1.2	
		I _{ON} =100mA, nB0 or nB1=0V, 0.7V, 1.6V, 2.3V Figure 3	2.30		1.1				
		I _{ON} =100mA, nB0 or nB1=0V, 0.7V, 1.65V Figure 3	1.65		1.5				
ΔR _{ON}	On Resistance Matching Between Channels ^(3,5)	I _{ON} =100mA, nB0 or nB1=0.7V	4.30		0.08			0.25	Ω
			3.00		0.20			0.25	
			2.30		0.40				
			1.65		0.50				
R _{FLAT(ON)}	On Resistance Flatness ^(4,5)	I _{OUT} =100mA, nB0 or nB1=0V to V _{CC}	4.30					0.4	Ω
			3.00					0.4	
			2.30		0.9				
			1.65		1.2				
I _{CC}	Quiescent Supply Current	V _{IN} =0 or V _{CC} , I _{OUT} =0	4.30	-100		100	-500	500	nA
I _{CC(T)}	Increase in I _{CC} per Input	Input at 2.6V	4.30		3			7	μA
		Input at 1.8V			7		15		

Notes:

- On resistance is determined by the voltage drop between A and B pins at the indicated current through the switch.
- ΔR_{ON}=R_{ON max} - R_{ON min} measured at identical V_{CC}, temperature, and voltage.
- Flatness is defined as the difference between the maximum and minimum value of on resistance (R_{ON}) over the specified range of conditions.
- Guaranteed by characterization, not production tested for V_{CC}=1.65 - 3.0V.

AC Electrical Characteristics

All typical value are for $V_{CC}=3.3V$ at $25^{\circ}C$ unless otherwise specified.

Symbol	Parameter	Conditions	V_{CC} (V)	$T_A=+25^{\circ}C$			$T_A=-40$ to $+85^{\circ}C$		Unit	Figure
				Min.	Typ.	Max.	Min.	Max.		
t_{ON}	Turn-On Time	nB0 or nB1=1.5V, $R_L=50\Omega$, $C_L=35pF$	3.60 to 4.30			55		60	ns	Figure 6 Figure 7
			2.70 to 3.60			60		65		
			2.30 to 2.70			65		70		
			1.65 to 1.95		70					
t_{OFF}	Turn-Off Time	nB0 or nB1=1.5V, $R_L=50\Omega$, $C_L=35pF$	3.60 to 4.30			30	5	35	ns	Figure 8
			2.70 to 3.60			35	5	40		
			2.30 to 2.70			40	5	45		
			1.65 to 1.95		40					
t_{BBM}	Break-Before-Make Time ⁽⁶⁾	nB0 or nB1=1.5V, $R_L=50\Omega$, $C_L=35pF$	3.60 to 4.30		15		2		ns	Figure 8
			2.70 to 3.60		15		2			
			2.30 to 2.70		15		2			
			1.65 to 1.95		16		2			
Q	Charge Injection ⁽⁶⁾	$C_L=1.0nF$, $V_S=0V$, $R_S=0\Omega$	1.65 to 4.30		25				pC	Figure 12
OIRR	Off Isolation ⁽⁶⁾	$f=100kHz$, $R_L=50\Omega$, $C_L=0pF$	1.65 to 4.30		-70				dB	Figure 10
Xtalk	Crosstalk ⁽⁶⁾	$f=100kHz$, $R_L=50\Omega$, $C_L=0pF$	1.65 to 4.30		-70				dB	Figure 11
BW	-3db Bandwidth ⁽⁶⁾	$R_L=50\Omega$, $C_L=0pF$	1.65 to 4.30		>50				MHz	Figure 9
THD+N	Total Harmonic Distortion + Noise ⁽⁶⁾	$f=20Hz$ to $20kHz$, $R_L=32\Omega$, $V_{IN}=2V_{PP}$	1.65 to 4.30		.06				%	Figure 15

Note:

6. Guaranteed by characterization, not production tested

Capacitance

All capacitance specifications are guaranteed by characterization and are not production tested.

Symbol	Parameter	Conditions	V_{CC} (V)	$T_A=+25^{\circ}C$			Unit	Figure
				Min.	Typ.	Max.		
C_{IN}	Control Pin Input Capacitance	$f=1MHz$	0		1.5		pF	Figure 13
C_{OFF}	B Port Off Capacitance	$f=1MHz$	3.3		30		pF	Figure 13
C_{ON}	A Port On Capacitance	$f=1MHz$	3.3		120		pF	Figure 14

Test Diagrams

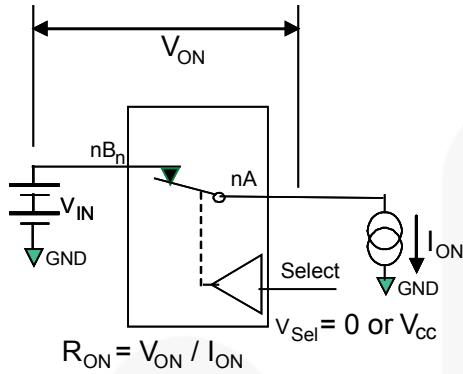
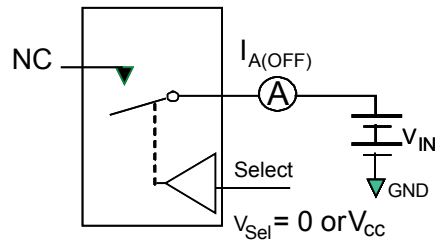

Figure 3. On Resistance



**Each switch port is tested separately.

Figure 4. Off Leakage (Ports Tested Separately)

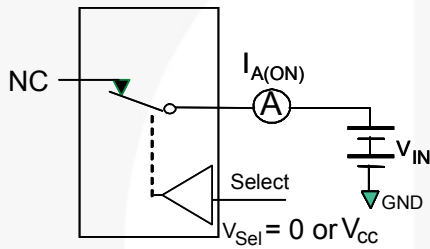

Figure 5. On Leakage

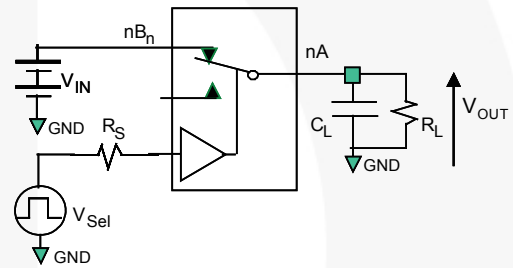

Figure 6. Test Circuit Load

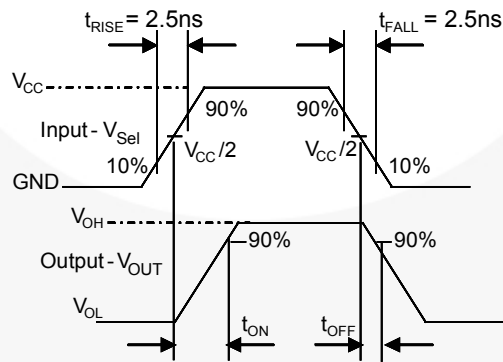

Figure 7. Turn-On / Turn-Off Waveforms

Test Diagrams (Continued)

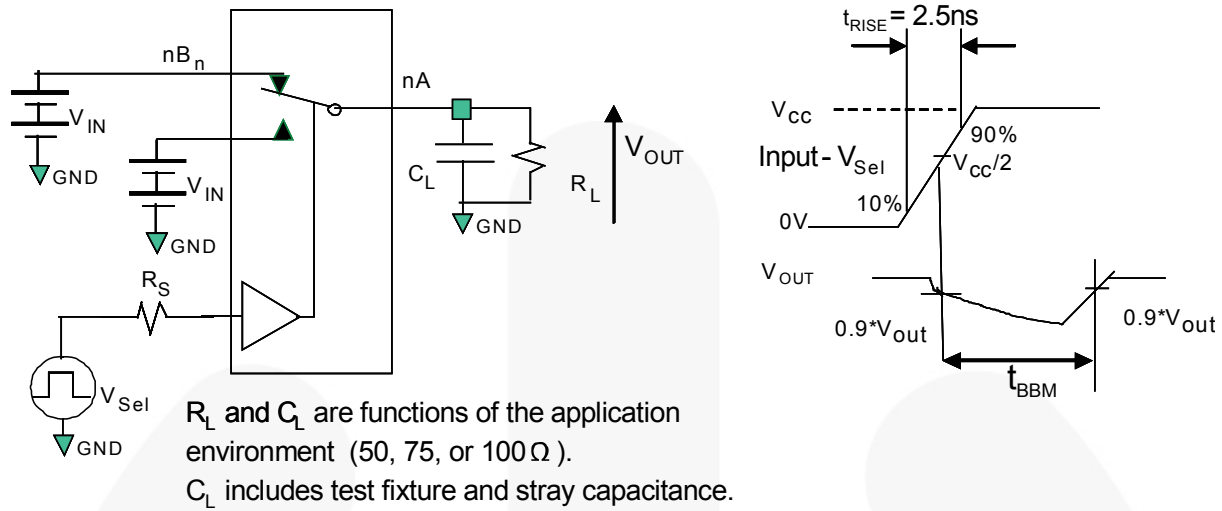

Figure 8. Break-Before-Make Interval Timing

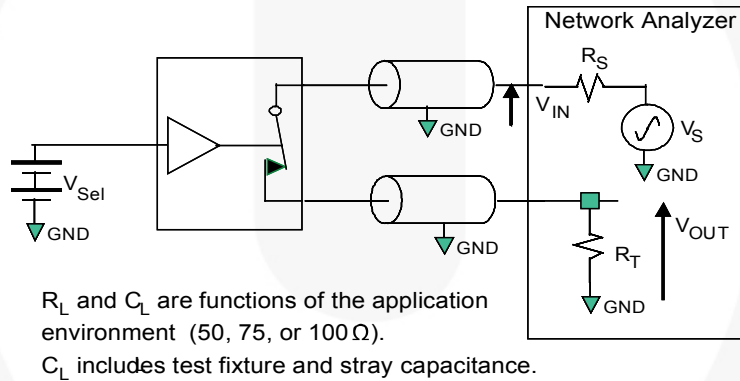

Figure 9. Bandwidth

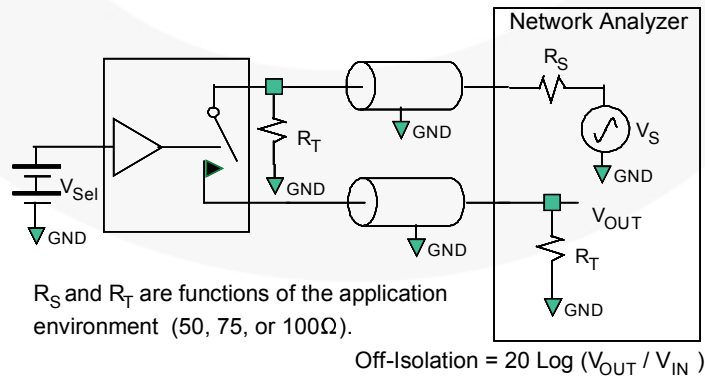

Figure 10. Channel Off Isolation

Test Diagrams (Continued)

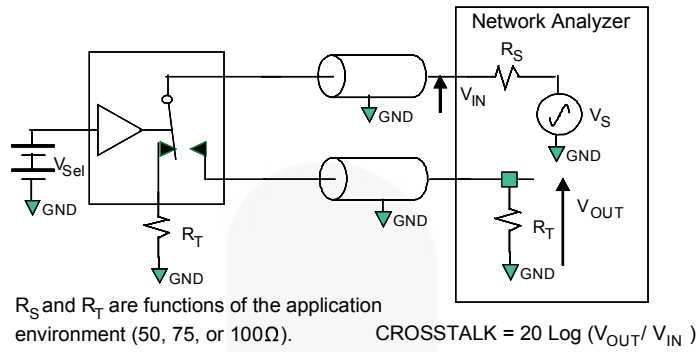

Figure 11. Adjacent Channel Crosstalk

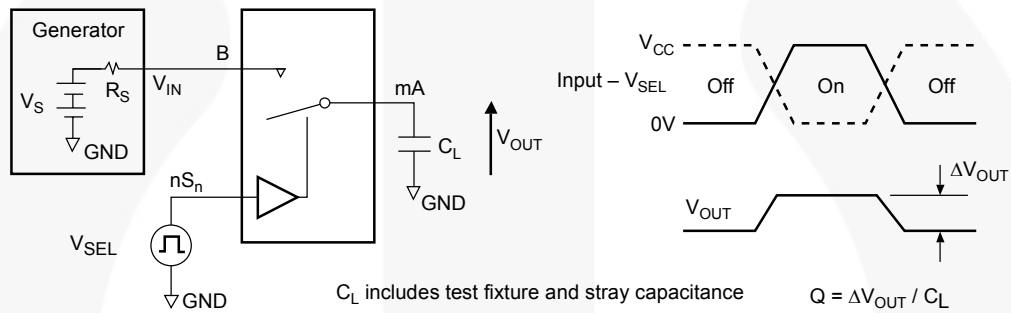

Figure 12. Charge Injection Test

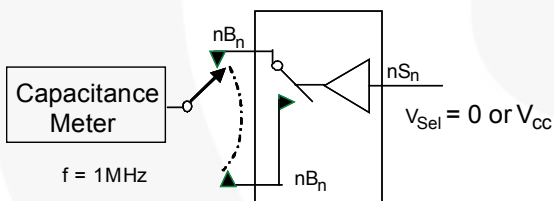

Figure 13. Channel Off Capacitance

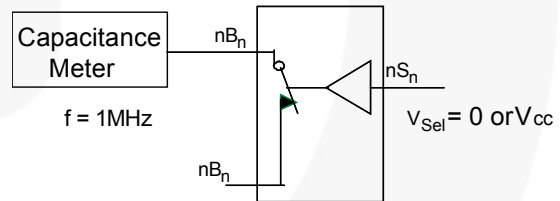

Figure 14. Channel On Capacitance

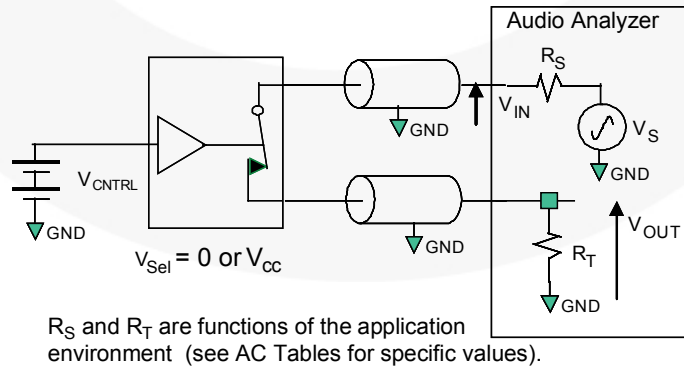

Figure 15. Total Harmonic Distortion

Physical Dimensions

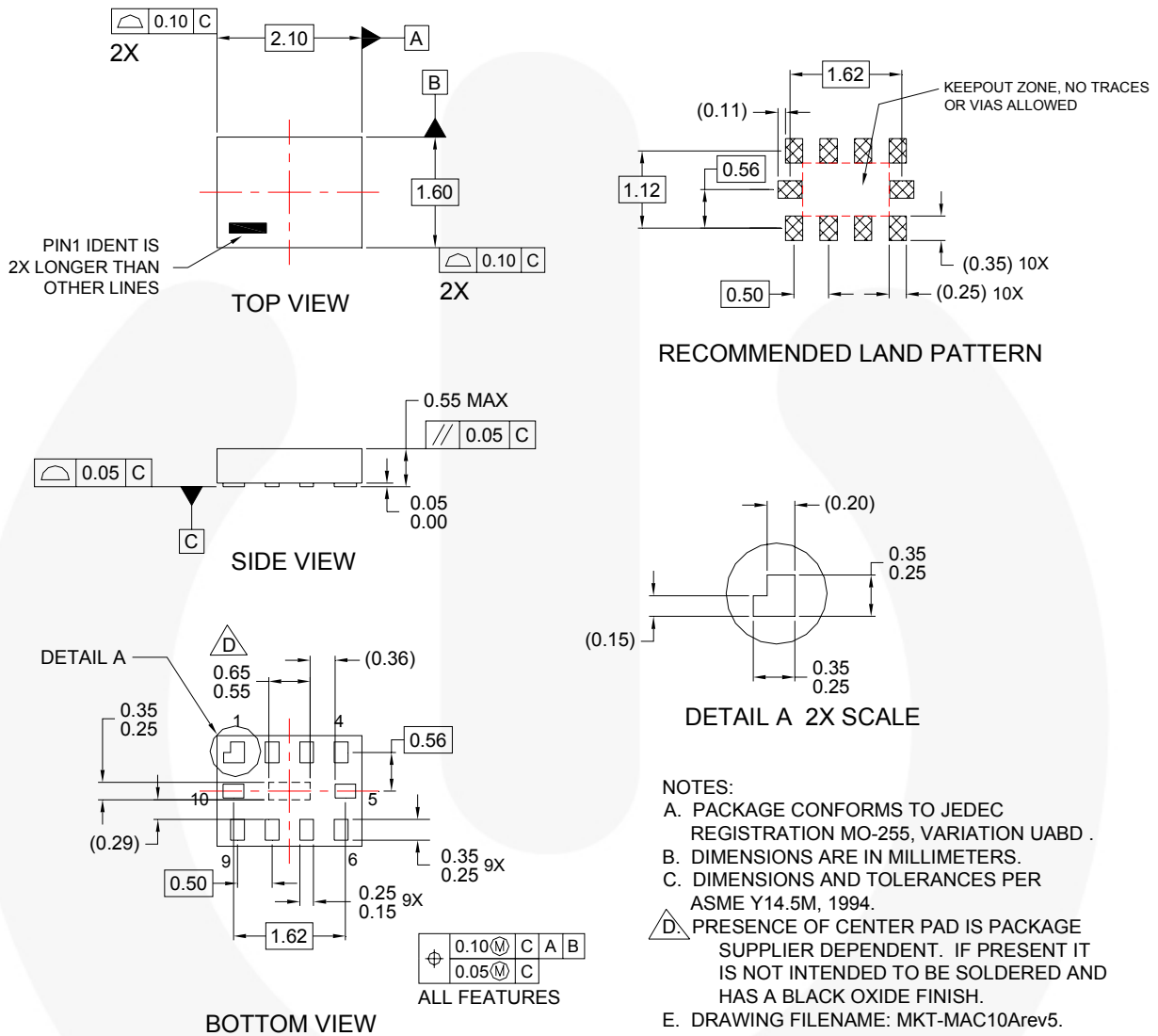

Figure 16. 10-Lead MicroPak™

Package drawings are provided as a service to customers considering Fairchild components. Drawings may change in any manner without notice. Please note the revision and/or date on the drawing and contact a Fairchild Semiconductor representative to verify or obtain the most recent revision. Package specifications do not expand the terms of Fairchild's worldwide terms and conditions, specifically the warranty therein, which covers Fairchild products.

Always visit Fairchild Semiconductor's online packaging area for the most recent package drawings:
<http://www.fairchildsemi.com/packaging/>



TRADEMARKS

The following includes registered and unregistered trademarks and service marks, owned by Fairchild Semiconductor and/or its global subsidiaries, and is not intended to be an exhaustive list of all such trademarks.

AccuPower™	FPST™	PowerTrench®	The Power Franchise®
Auto-SPM™	F-PFST™	PowerXS™	
Build it Now™	FRFET®	Programmable Active Droop™	TinyBoost™
CorePLUSTM	Global Power Resource SM	QFET®	TinyBuck™
CorePOWER™	Green FPS™	QS™	TinyCalc™
CROSSVOLT™	Green FPS™ e-Series™	RapidConfigure™	TinyLogic®
CTL™	Gmax™		TINYOPTO™
Current Transfer Logic™	GTO™	Saving our world, 1mW/W/KW at a time™	TinyPower™
EcoSPARK®	IntelliMAX™	SmartMax™	TinyPWM™
EfficientMax™	ISOPLANAR™	SMART START™	TinyWire™
EZSWITCH™	MegaBuck™	SPM®	TriFault Detect™
	MICROCOUPLER™	STEALTH™	TRUECURRENT™
	MicroFET™	SuperFET™	μSerDes™
Fairchild®	MicroPak™	SuperSOT™.3	
Fairchild Semiconductor®	MillerDrive™	SuperSOT™.6	UHC®
FACT Quiet Series™	MotionMax™	SuperSOT™.8	Ultra FRFET™
FACT™	Motion-SPM™	SupreMOS™	UniFET™
FACT®	OPTOLOGIC®	SyncFET™	VCX™
FAST®	OPTOPLANAR®	Sync-Lock™	VisualMax™
FastvCore™		SYSTEM SM	XST™
FETBench™	PDP SPM™		
FlashWriter SM	Power-SPM™		

* Trademarks of System General Corporation, used under license by Fairchild Semiconductor.

DISCLAIMER

FAIRCHILD SEMICONDUCTOR RESERVES THE RIGHT TO MAKE CHANGES WITHOUT FURTHER NOTICE TO ANY PRODUCTS HEREIN TO IMPROVE RELIABILITY, FUNCTION, OR DESIGN. FAIRCHILD DOES NOT ASSUME ANY LIABILITY ARISING OUT OF THE APPLICATION OR USE OF ANY PRODUCT OR CIRCUIT DESCRIBED HEREIN; NEITHER DOES IT CONVEY ANY LICENSE UNDER ITS PATENT RIGHTS, NOR THE RIGHTS OF OTHERS. THESE SPECIFICATIONS DO NOT EXPAND THE TERMS OF FAIRCHILD'S WORLDWIDE TERMS AND CONDITIONS, SPECIFICALLY THE WARRANTY THEREIN, WHICH COVERS THESE PRODUCTS.

LIFE SUPPORT POLICY

FAIRCHILD'S PRODUCTS ARE NOT AUTHORIZED FOR USE AS CRITICAL COMPONENTS IN LIFE SUPPORT DEVICES OR SYSTEMS WITHOUT THE EXPRESS WRITTEN APPROVAL OF FAIRCHILD SEMICONDUCTOR CORPORATION.

As used herein:

1. Life support devices or systems are devices or systems which, (a) are intended for surgical implant into the body or (b) support or sustain life, and (c) whose failure to perform when properly used in accordance with instructions for use provided in the labeling, can be reasonably expected to result in a significant injury of the user.
2. A critical component in any component of a life support, device, or system whose failure to perform can be reasonably expected to cause the failure of the life support device or system, or to affect its safety or effectiveness.

ANTI-COUNTERFEITING POLICY

Fairchild Semiconductor Corporation's Anti-Counterfeiting Policy. Fairchild's Anti-Counterfeiting Policy is also stated on our external website, www.fairchildsemi.com, under Sales Support.

Counterfeiting of semiconductor parts is a growing problem in the industry. All manufacturers of semiconductor products are experiencing counterfeiting of their parts. Customers who inadvertently purchase counterfeit parts experience many problems such as loss of brand reputation, substandard performance, failed applications, and increased cost of production and manufacturing delays. Fairchild is taking strong measures to protect ourselves and our customers from the proliferation of counterfeit parts. Fairchild strongly encourages customers to purchase Fairchild parts either directly from Fairchild or from Authorized Fairchild Distributors who are listed by country on our web page cited above. Products customers buy either from Fairchild directly or from Authorized Fairchild Distributors are genuine parts, have full traceability, meet Fairchild's quality standards for handling and storage and provide access to Fairchild's full range of up-to-date technical and product information. Fairchild and our Authorized Distributors will stand behind all warranties and will appropriately address any warranty issues that may arise. Fairchild will not provide any warranty coverage or other assistance for parts bought from Unauthorized Sources. Fairchild is committed to combat this global problem and encourage our customers to do their part in stopping this practice by buying direct or from authorized distributors.

PRODUCT STATUS DEFINITIONS

Definition of Terms

Datasheet Identification	Product Status	Definition
Advance Information	Formative / In Design	Datasheet contains the design specifications for product development. Specifications may change in any manner without notice.
Preliminary	First Production	Datasheet contains preliminary data; supplementary data will be published at a later date. Fairchild Semiconductor reserves the right to make changes at any time without notice to improve design.
No Identification Needed	Full Production	Datasheet contains final specifications. Fairchild Semiconductor reserves the right to make changes at any time without notice to improve the design.
Obsolete	Not In Production	Datasheet contains specifications on a product that is discontinued by Fairchild Semiconductor. The datasheet is for reference information only.

Rev. I41