

Flash

3V Only 4 Mbit Serial Flash Memory

■ FEATURES

- Single supply voltage 2.7~3.6V
- Speed
 - Read max frequency : 33MHz
 - Fast Read max frequency : 50MHz; 75MHz; 100MHz
- Low power consumption
 - Active current : 40mA
 - Standby current : 75 μ A
- Reliability
 - 100,000 typical program/erase cycles
 - 20 years Data Retention
- Program
 - Byte program time 7 μ s (typical)
- Erase
 - Chip erase time 4s (typical)
 - Block erase time 1sec (typical)
 - Sector erase time 90ms (typical)
- Auto Address Increment (AAI) WORD Programming
 - Decrease total chip programming time over Byte-Program operations
- SPI Serial Interface
 - SPI Compatible : Mode 0 and Mode3
- End of program or erase detection
- Write Protect (\overline{WP})
- Hold Pin (\overline{HOLD})
- All Pb-free products are RoHS-Compliant

ORDERING INFORMATION

Part No.	Speed	Package		COMMENTS
F25L004A -50PG	50MHz	8 lead SOIC	150 mil	Pb-free
F25L004A -100PG	100MHz	8 lead SOIC	150 mil	Pb-free
F25L004A -50PAG	50MHz	8 lead SOIC	200 mil	Pb-free

Part No.	Speed	Package		COMMENTS
F25L004A -100PAG	100MHz	8 lead SOIC	200 mil	Pb-free
F25L004A -50DG	50MHz	8 lead PDIP	300 mil	Pb-free
F25L004A -100DG	100MHz	8 lead PDIP	300 mil	Pb-free

GENERAL DESCRIPTION

The F25L004A is a 4 Megabit 3V only CMOS Serial Flash memory device. ESMT's memory devices reliably store memory data even after 100,000 program and erase cycles.

The F25L004A features a sector erase architecture. The device memory array is divided into 128 uniform sectors with 4K byte each ; 8 uniform blocks with 64K byte each. Sectors can be erased individually without affecting the data in other sectors.

Blocks can be erased individually without affecting the data in other blocks. Whole chip erase capabilities provide the flexibility to revise the data in the device.

The sector protect/unprotect feature disables both program and erase operations in any combination of the sectors of the memory.

PIN CONFIGURATIONS

8-PIN SOIC

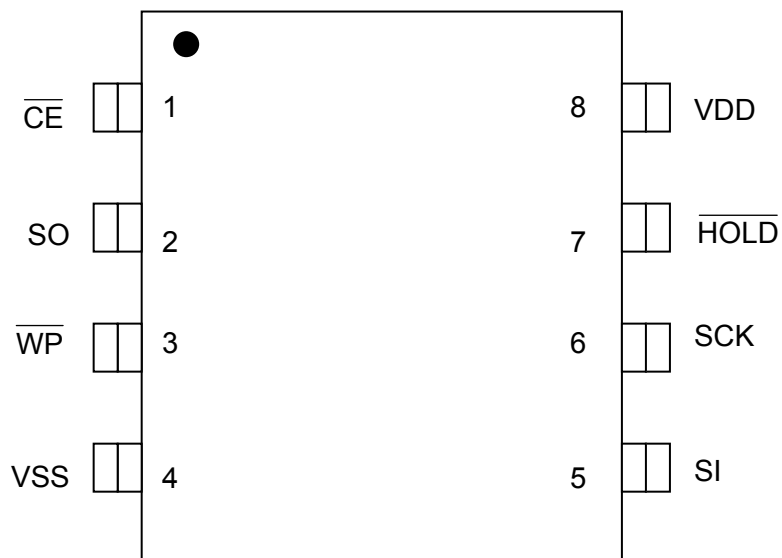

8-PIN PDIP

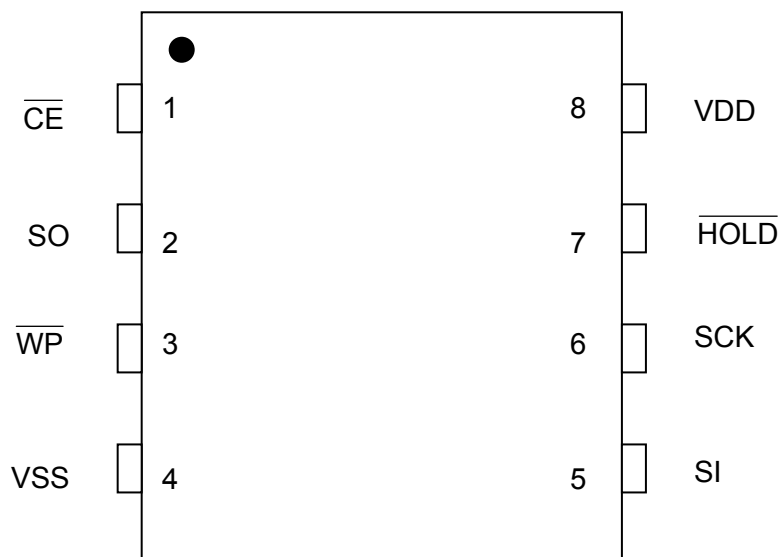

PIN Description

Symbol	Pin Name	Functions
SCK	Serial Clock	To provide the timing for serial input and output operations
SI	Serial Data Input	To transfer commands, addresses or data serially into the device. Data is latched on the rising edge of SCK.
SO	Serial Data Output	To transfer data serially out of the device. Data is shifted out on the falling edge of SCK.
\overline{CE}	Chip Enable	To activate the device when \overline{CE} is low.
\overline{WP}	Write Protect	The Write Protect (\overline{WP}) pin is used to enable/disable BPL bit in the status register.
\overline{HOLD}	Hold	To temporality stop serial communication with SPI flash memory without resetting the device.
VDD	Power Supply	To provide power.
VSS	Ground	

SECTOR STRUCTURE

Table1 : F25L004A Sector Address Table

Block	Sector	Sector Size (Kbytes)	Address range	Block Address		
				A18	A17	A16
7	127	4KB	07F000H – 07FFFFH	1	1	1
	:	:	:			
6	112	4KB	070000H – 070FFFH	1	1	0
	111	4KB	06F000H – 06FFFFH			
	:	:	:			
5	96	4KB	060000H – 060FFFH	1	0	1
	95	4KB	05F000H – 05FFFFH			
	:	:	:			
4	80	4KB	050000H – 050FFFH	1	0	0
	79	4KB	04F000H – 04FFFFH			
	:	:	:			
3	64	4KB	040000H – 040FFFH	0	1	1
	63	4KB	03F000H – 03FFFFH			
	:	:	:			
2	48	4KB	030000H – 030FFFH	0	1	0
	47	4KB	02F000H – 02FFFFH			
	:	:	:			
1	32	4KB	020000H – 020FFFH	0	0	1
	31	4KB	01F000H – 01FFFFH			
	:	:	:			
0	16	4KB	010000H – 010FFFH	0	0	0
	15	4KB	00F000H – 00FFFFH			
	0	4KB	000000H – 000FFFH			

Table2 : F25L004A Block Protection Table

Protection Level	Status Register Bit			Protected Memory Area	
	BP2	BP1	BP0	Block Range	Address Range
0	0	0	0	None	None
Upper 1/8	0	0	1	Block 7	70000H – 7FFFFH
Upper 1/4	0	1	0	Block 6~7	60000H – 7FFFFH
Upper 1/2	0	1	1	Block 4~7	40000H – 7FFFFH
All Blocks	1	0	0	Block 0~7	00000H – 7FFFFH
All Blocks	1	0	1	Block 0~7	00000H – 7FFFFH
All Blocks	1	1	0	Block 0~7	00000H – 7FFFFH
All Blocks	1	1	1	Block 0~7	00000H – 7FFFFH

Block Protection (BP2, BP1, BP0)

The Block-Protection (BP2, BP1, BP0) bits define the size of the memory area, as defined in Table2 to be software protected against any memory Write (Program or Erase) operations. The Write-Status-Register (WRSR) instruction is used to program the BP2, BP1, BP0 bits as long as \overline{WP} is high or the Block-Protection-Look (BPL) bit is 0. Chip-Erase can only be executed if Block-Protection bits are all 0. After power-up, BP2, BP1 and BP0 are set to 1.

Block Protection Lock-Down (BPL)

\overline{WP} pin driven low (V_{IL}), enables the Block-Protection-Lock-Down (BPL) bit. When BPL is set to 1, it prevents any further alteration of the BPL, BP2, BP1, and BP0 bits. When the \overline{WP} pin is driven high (V_{IH}), the BPL bit has no effect and its value is "Don't Care". After power-up, the BPL bit is reset to 0.

FUNTIONAL BLOCK DIAGRAM

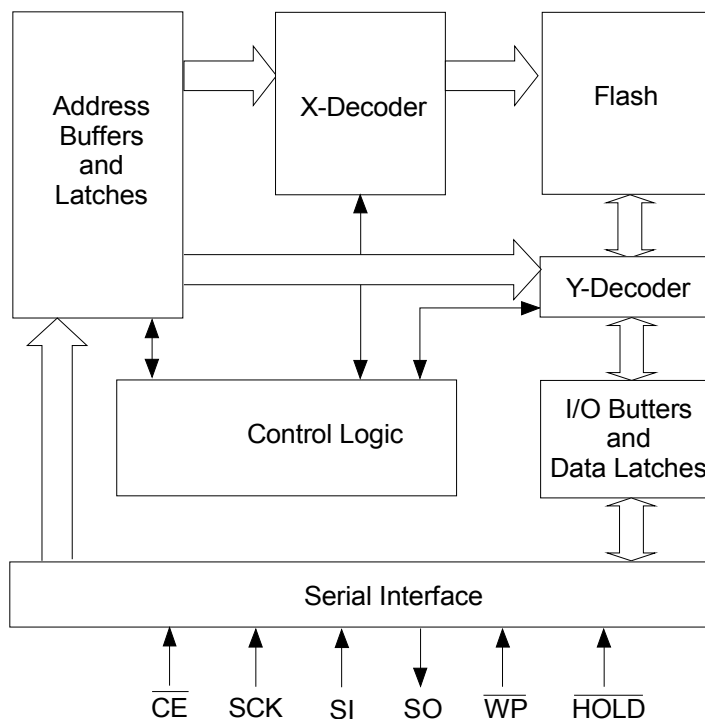

Hold Operation

$\overline{\text{HOLD}}$ pin is used to pause a serial sequence underway with the SPI flash memory without resetting the clocking sequence. To activate the $\overline{\text{HOLD}}$ mode, $\overline{\text{CE}}$ must be in active low state. The $\overline{\text{HOLD}}$ mode begins when the SCK active low state coincides with the falling edge of the $\overline{\text{HOLD}}$ signal. The HOLD mode ends when the $\overline{\text{HOLD}}$ signal's rising edge coincides with the SCK active low state.

If the falling edge of the $\overline{\text{HOLD}}$ signal does not coincide with the SCK active low state, then the device enters Hold mode when the SCK next reaches the active low state.

Similarly, if the rising edge of the $\overline{\text{HOLD}}$ signal does not

coincide with the SCK active low state, then the device exits in Hold mode when the SCK next reaches the active low state. See Figure 1 for Hold Condition waveform.

Once the device enters Hold mode, SO will be in high impedance state while SI and SCK can be V_{IL} or V_{IH} .

If $\overline{\text{CE}}$ is driven active high during a Hold condition, it resets the internal logic of the device. As long as $\overline{\text{HOLD}}$ signal is low, the memory remains in the Hold condition. To resume communication with the device, $\overline{\text{HOLD}}$ must be driven active high, and $\overline{\text{CE}}$ must be driven active low. See Figure 21 for Hold timing.

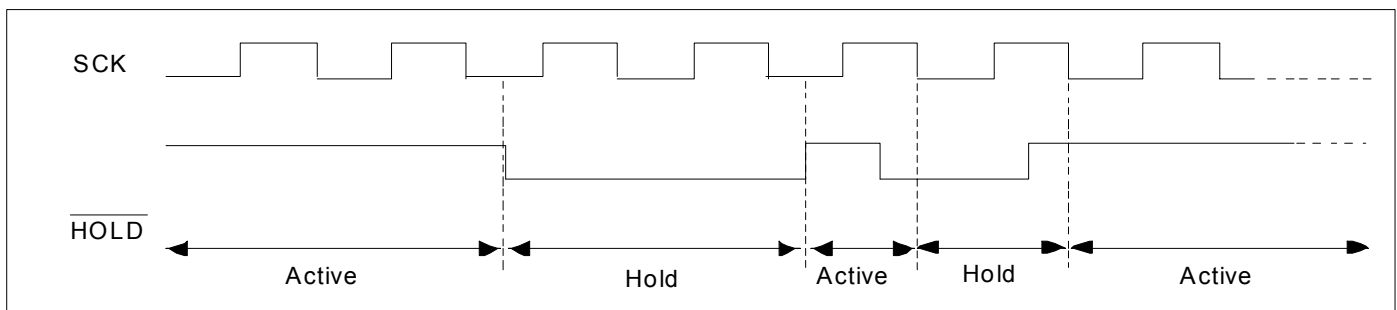

Figure 1 : HOLD CONDITION WAVEFORM

Write Protection

F25L004A provides software Write protection.

The Write Protect pin ($\overline{\text{WP}}$) enables or disables the lockdown function of the status register. The Block-Protection bits (BP1, BP0, and BPL) in the status register provide Write protection to the memory array and the status register. See Table 2 for Block-Protection description.

Write Protect Pin ($\overline{\text{WP}}$)

The Write Protect ($\overline{\text{WP}}$) pin enables the lock-down function of the BPL bit (bit 7) in the status register. When $\overline{\text{WP}}$ is driven low, the execution of the Write-Status-Register (WRSR) instruction is determined by the value of the BPL bit (see Table 3). When $\overline{\text{WP}}$ is high, the lock-down function of the BPL bit is disabled.

TABLE3: CONDITIONS TO EXECUTE WRITE-STATUS- REGISTER (WRSR) INSTRUCTION

$\overline{\text{WP}}$	BPL	Execute WRSR Instruction
L	1	Not Allowed
L	0	Allowed
H	X	Allowed

Status Register

The software status register provides status on whether the flash memory array is available for any Read or Write operation, whether the device is Write enabled, and the state of the memory Write protection. During an internal Erase or Program operation,

the status register may be read only to determine the completion of an operation in progress.

Table 4 describes the function of each bit in the software status register.

TABLE 4: SOFTWARE STATUS REGISTER

Bit	Name	Function	Default at Power-up	Read/Write
0	BUSY	1 = Internal Write operation is in progress 0 = No internal Write operation is in progress	0	R
1	WEL	1 = Device is memory Write enabled 0 = Device is not memory Write enabled	0	R
2	BP0	Indicate current level of block write protection (See Table 2)	1	R/W
3	BP1	Indicate current level of block write protection (See Table 2)	1	R/W
4	BP2	Indicate current level of block write protection (See Table 2)	1	R/W
5	RESERVED	Reserved for future use	0	N/A
6	AAI	Auto Address Increment Programming status 1 = AAI programming mode 0 = Byte-Program mode	0	R
7	BPL	1 = BP2,BP1,BP0 are read-only bits 0 = BP2,BP1,BP0 are read/writable	0	R/W

Note1 : Only BP0,BP1,BP2 and BPL are writable

Note2 : All register bits are volatility

Note3 : All area are protected at power-on (BP2=BP1=BP0=1)

Busy

The Busy bit determines whether there is an internal Erase or Program operation in progress. A “1” for the Busy bit indicates the device is busy with an operation in progress. A “0” indicates the device is ready for the next valid operation.

Write Enable Latch (WEL)

The Write-Enable-Latch bit indicates the status of the internal memory Write Enable Latch. If the Write-Enable-Latch bit is set to “1”, it indicates the device is Write enabled. If the bit is set to “0” (reset), it indicates the device is not Write enabled and does not accept any memory Write (Program/ Erase) commands. The Write-Enable-Latch bit is automatically reset under the following conditions:

- Power-up
- Write-Disable (WRDI) instruction completion
- Byte-Program instruction completion
- Auto Address Increment (AAI) programming reached its highest memory address
- Sector-Erase instruction completion
- Block-Erase instruction completion
- Chip-Erase instruction completion
- Write-Status-Register instructions

Instructions

Instructions are used to Read, Write (Erase and Program), and configure the F25L004A. The instruction bus cycles are 8 bits each for commands (Op Code), data, and addresses. Prior to executing any Byte-Program, Auto Address Increment (AAI) programming, Sector-Erase, Block-Erase, or Chip-Erase instructions, the Write-Enable (WREN) instruction must be executed first. The complete list of the instructions is provided in Table 5. All instructions are synchronized off a high to low transition of \overline{CE} . Inputs will be accepted on the rising edge of

SCK starting with the most significant bit. \overline{CE} must be driven low before an instruction is entered and must be driven high after the last bit of the instruction has been shifted in (except for Read, Read-ID and Read-Status-Register instructions). Any low to high transition on \overline{CE} , before receiving the last bit of an instruction bus cycle, will terminate the instruction in progress and return the device to the standby mode.

Instruction commands (Op Code), addresses, and data are all input from the most significant bit (MSB) first

TABLE 5: DEVICE OPERATION INSTRUCTIONS

Cycle Type/ Operation ^{1,2}	Max Freq	Bus Cycle											
		1		2		3		4		5		6	
		S _{IN}	S _{OUT}	S _{IN}	S _{OUT}	S _{IN}	S _{OUT}	S _{IN}	S _{OUT}	S _{IN}	S _{OUT}	S _{IN}	S _{OUT}
Read	33 MHz	03H	Hi-Z	A ₂₃ -A ₁₆	Hi-Z	A ₁₅ -A ₈	Hi-Z	A ₇ -A ₀	Hi-Z	X	D _{OUT}		
High-Speed-Read		0BH	Hi-Z	A ₂₃ -A ₁₆	Hi-Z	A ₁₅ -A ₈	Hi-Z	A ₇ -A ₀	Hi-Z	X	X	X	D _{OUT}
Sector-Erase ^{4,5} (4K Byte)		20H	Hi-Z	A ₂₃ -A ₁₆	Hi-Z	A ₁₅ -A ₈	Hi-Z	A ₇ -A ₀	Hi-Z	-	-	-	-
Block-Erase ⁵ (64K Byte)		D8H	Hi-Z	A ₂₃ -A ₁₆	Hi-Z	A ₁₅ -A ₈	Hi-Z	A ₇ -A ₀	Hi-Z	-	-	-	-
Chip-Erase ⁵		60H C7H	Hi-Z	-	-	-	-	-	-	-	-	-	-
Byte-Program ⁵		02H	Hi-Z	A ₂₃ -A ₁₆	Hi-Z	A ₁₅ -A ₈	Hi-Z	A ₇ -A ₀	Hi-Z	D _{IN}	Hi-Z	-	-
Auto-Address-Increment-word programming (AAI) ⁶		ADH	Hi-Z	A ₂₃ -A ₁₆	Hi-Z	A ₁₅ -A ₈	Hi-Z	A ₇ -A ₀	Hi-Z	D _{IN0}	Hi-Z	D _{IN1}	Hi-Z
Read-Status-Register (RDSR)	50MHz	05H	Hi-Z	X	D _{OUT}	-	Note ⁷	-	Note ⁷	-	Note ⁷	-	-
Enable-Write-Status-Register (EWSR) ⁸		50H	Hi-Z	-	-	-	-	-	-	-	-	-	-
Write-Status-Register (WRSR) ⁸		01H	Hi-Z	Data	Hi-Z	-	-	-	-	-	-	-	-
Write-Enable (WREN) ¹¹		06H	Hi-Z	-	-	-	-	-	-	-	-	-	-
Write-Disable (WRDI)		04H	Hi-Z	-	-	-	-	-	-	-	-	-	-
Read-Electronic-Signature ⁹ (RES)	100MHz	ABH	Hi-Z	X	12H	-	-	-	-	-	-	-	-
Jedec-Read-ID (JEDEC-ID) ¹⁰		9FH	Hi-Z	X	8CH	X	20H	X	13H	-	-	-	-
Read-ID (RDID)		90H (A0=0)	Hi-Z	A ₂₃ -A ₁₆	Hi-Z	A ₁₅ -A ₈	Hi-Z	A ₇ -A ₀	Hi-Z	X	8CH	X	12H
		90H (A0=1)									12H		8CH
Enable SO to output RY/BY# Status during AAI (EBSY)		70H	Hi-Z	-	-	-	-	-	-	-	-	-	-
Disable SO to output RY/BY# Status during AAI (DBSY)		80H	Hi-Z	-	-	-	-	-	-	-	-	-	-

1. Operation: S_{IN} = Serial In, S_{OUT} = Serial Out
2. X = Dummy Input Cycles (V_{IL} or V_{IH}); - = Non-Applicable Cycles (Cycles are not necessary)
3. One bus cycle is eight clock periods.
4. Sector addresses: use AMS-A12, remaining addresses can be V_{IL} or V_{IH}
5. Prior to any Byte-Program, Sector-Erase, Block-Erase, or Chip-Erase operation, the Write-Enable (WREN) instruction must be executed.
6. To continue programming to the next sequential address location, enter the 8-bit command, ADH, followed by the data to be programmed.
7. The Read-Status-Register is continuous with ongoing clock cycles until terminated by a low to high transition on \overline{CE} .
8. The Enable-Write-Status-Register (EWSR) instruction and the Write-Status-Register (WRSR) instruction must work in conjunction of each other. The WRSR instruction must be executed immediately (very next bus cycle) after the EWSR instruction to make both instructions effective.
9. The Read-Electronic-Signature is continuous with on going clock cycles until terminated by a low to high transition on \overline{CE} .

10. The Jedec-Read-ID is output first byte 8CH as manufacture ID; second byte 20H as top memory type; third byte 13H as memory capacity.
11. The Write-Enable (WREN) instruction and the Write-Status-Register (WRSR) instruction must work in conjunction of each other. The WRSR instruction must be executed immediately (very next bus cycle) after the WREN instruction to make both instructions effective. Both EWSR and WREN can enable WRSR, user just need to execute one of it. A successful WRSR can reset WREN.

Read (33 MHz)

The Read instruction supports up to 33 MHz, it outputs the data starting from the specified address location. The data output stream is continuous through all addresses until terminated by a low to high transition on \overline{CE} . The internal address pointer will automatically increment until the highest memory address is reached. Once the highest memory address is reached, the address pointer will automatically increment to the beginning

(wrap-around) of the address space, i.e. for 4Mbit density, once the data from address location 7FFFFH had been read, the next output will be from address location 00000H.

The Read instruction is initiated by executing an 8-bit command, 03H, followed by address bits [A₂₃-A₀]. \overline{CE} must remain active low for the duration of the Read cycle. See Figure 2 for the Read sequence.

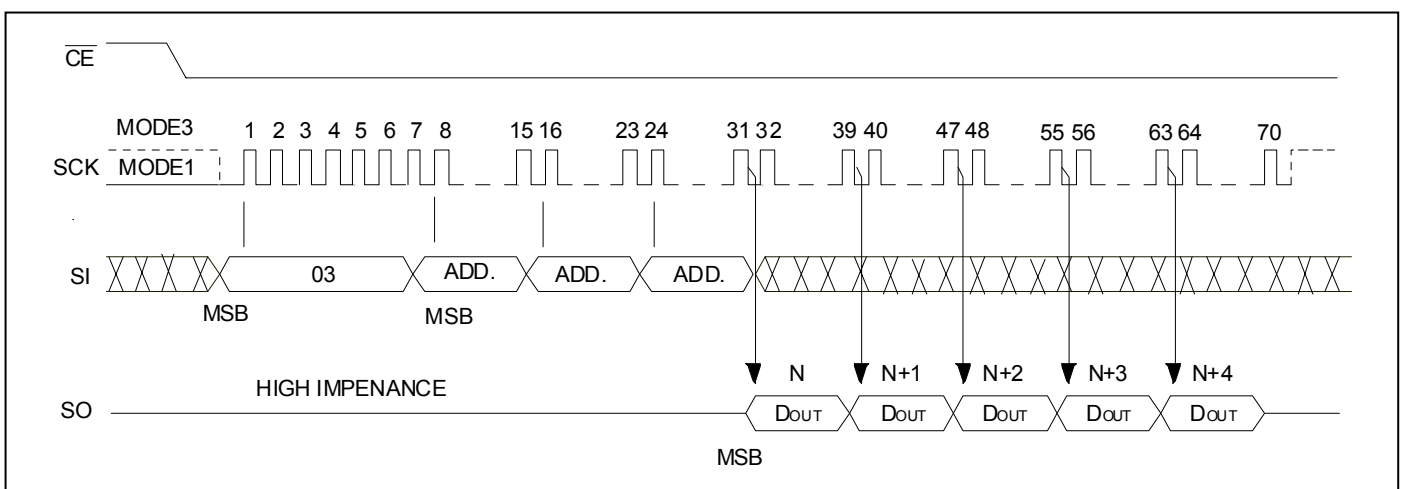

Figure 2 : READ SEQUENCE

Fast-Read (50 MHz ; 100 MHz)

The High-Speed-Read instruction supporting up to 100 MHz is initiated by executing an 8-bit command, 0BH, followed by address bits [A₂₃-A₀] and a dummy byte. \overline{CE} must remain active low for the duration of the High-Speed-Read cycle. See Figure 3 for the High-Speed-Read sequence.

Following a dummy byte (8 clocks input dummy cycle), the High-Speed-Read instruction outputs the data starting from the specified address location. The data output stream is continuous

through all addresses until terminated by a low to high transition on \overline{CE} . The internal address pointer will automatically increment until the highest memory address is reached. Once the highest memory address is reached, the address pointer will automatically increment to the beginning (wrap-around) of the address space, i.e. for 4Mbit density, once the data from address location 7FFFFH has been read, the next output will be from address location 00000H.

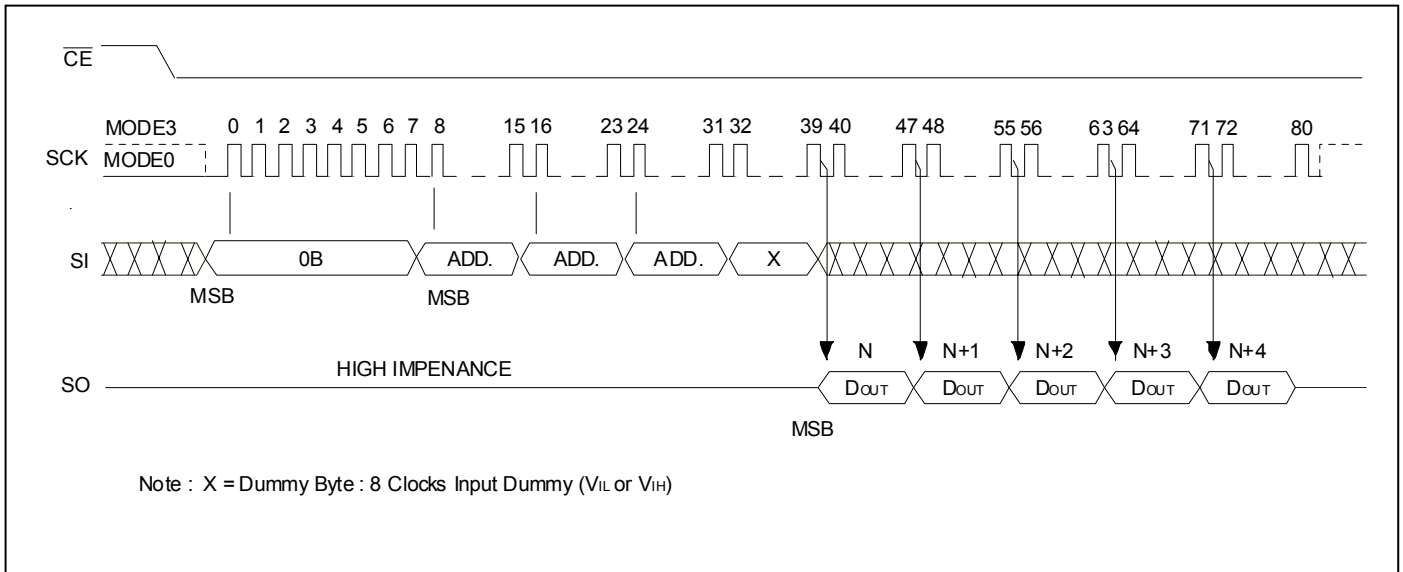

Figure 3 : HIGH-SPEED-READ SEQUENCE

Byte-Program

The Byte-Program instruction programs the bits in the selected byte to the desired data. The selected byte must be in the erased state (FFH) when initiating a Program operation. A Byte-Program instruction applied to a protected memory area will be ignored. Prior to any Write operation, the Write-Enable (WREN) instruction must be executed. \overline{CE} must remain active low for the duration of the Byte-Program instruction. The Byte-Program

instruction is initiated by executing an 8-bit command, 02H, followed by address bits [A₂₃-A₀]. Following the address, the data is input in order from MSB (bit 7) to LSB (bit 0). \overline{CE} must be driven high before the instruction is executed. The user may poll the Busy bit in the software status register or wait TBP for the completion of the internal self-timed Byte-Program operation. See Figure 4 for the Byte-Program sequence.

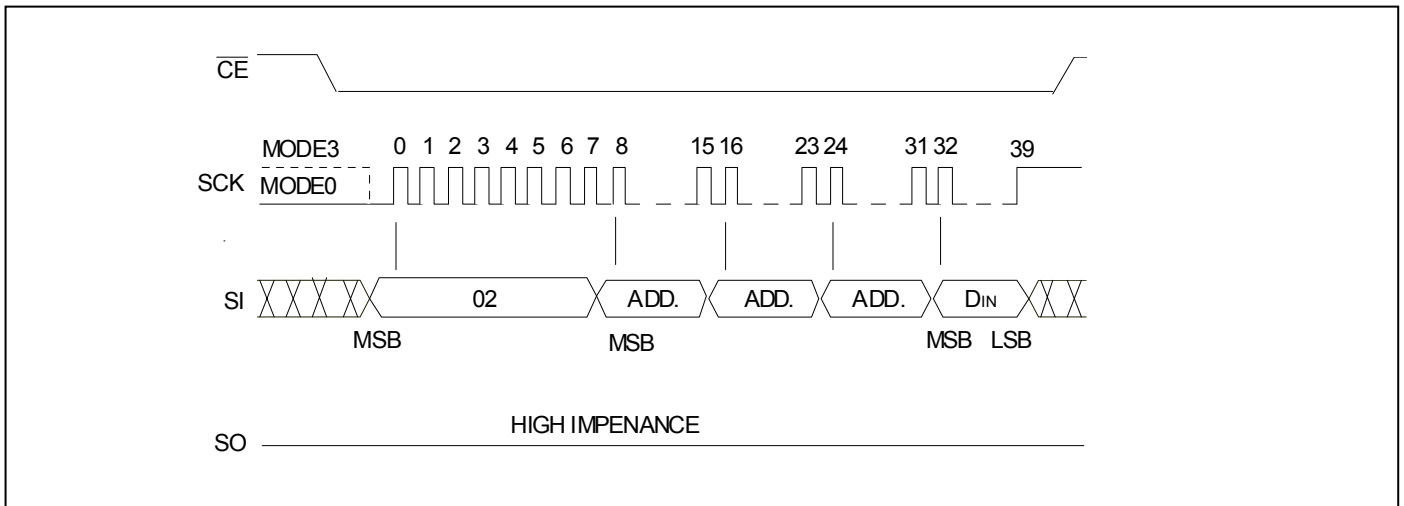

Figure 4 : BYTE-PROGRAM SEQUENCE

Auto Address Increment (AAI) WORD Program

The AAI program instruction allows multiple bytes of data to be programmed without re-issuing the next sequential address location. This feature decreases total programming time when the multiple bytes or entire memory array is to be programmed. An AAI program instruction pointing to a protected memory area will be ignored. The selected address range must be in the erased state (FFH) when initiating an AAI program instruction. While within AAI WORD programming sequence, the only valid instructions are AAI WORD program operation, RDSR, WRDI. Users have three options to determine the completion of each AAI WORD program cycle: hardware detection by reading the SO; software detection by polling the BUSY in the software status register or wait T_{BP} . Refer to End-of-Write Detection section for details.

Prior to any write operation, the Write-Enable (WREN) instruction must be executed. The AAI WORD program instruction is initiated by executing an 8-bit command, ADH, followed by address bits $[A_{23}-A_0]$. Following the addresses, two bytes of data is input sequentially. The data is input sequentially from MSB (bit 7) to LSB (bit 0). The first byte of data(D0) will be programmed into the initial address $[A_{23}-A_1]$ with $A_0=0$; The second byte of data(D1) will be programmed into the initial address $[A_{23}-A_1]$ with $A_0=1$. \overline{CE} must be driven high before the AAI WORD program instruction is executed. The user must check the BUSY status before entering the next valid command. Once the device indicates it is no longer busy, data for next two sequential addresses may be programmed and so on. When the last desired byte had been entered, check the busy status using the hardware method or the RDSR instruction and execute the WRDI instruction, to terminate AAI. User must check busy status after WRDI to determine if the device is ready for any command. Please refer to Figures 7 and Figures 8.

There is no wrap mode during AAI programming; once the highest unprotected memory address is reached, the device will exit AAI operation and reset the Write-Enable-Latch bit ($WEL = 0$) and the AAI bit ($AAI=0$).

End of Write Detection

There are three methods to determine completion of a program cycle during AAI WORD programming: hardware detection by reading the SO, software detection by polling the BUSY bit in the Software Status Register or wait T_{BP} . The hardware end of write detection method is described in the section below.

Hardware End of Write Detection

The hardware end of write detection method eliminates the overhead of polling the BUSY bit in the software status register during an AAI Word PROGRAM OPERATION. The 8bit command, 70H, configures the SO to indicate Flash Busy status during AAI WORD programming (refer to figure5). The 8bit command, 70H, must be executed prior to executing an AAI WORD program instruction. Once an internal programming operation begins, asserting \overline{CE} will immediately drive the status of the internal flash status on the SO pin. A “0” Indicates the device is busy ; a “1” Indicates the device is ready for the next instruction. De-asserting \overline{CE} will return the SO pin to tri-state. The 8bit command, 80H, disables the SO pin to output busy status during AAI WORD program operation and return SO pin to output software register data during AAI WORD programming (refer to figure6).

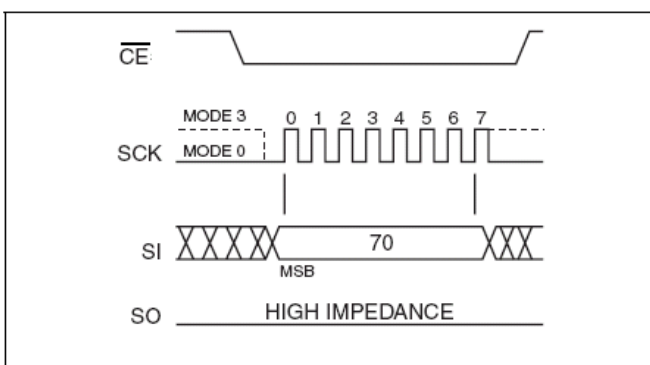

FIGURE 5 : ENABLE SO AS HARDWARE $\overline{RY}/\overline{BY}$ DURING AAI PROGRAMMING

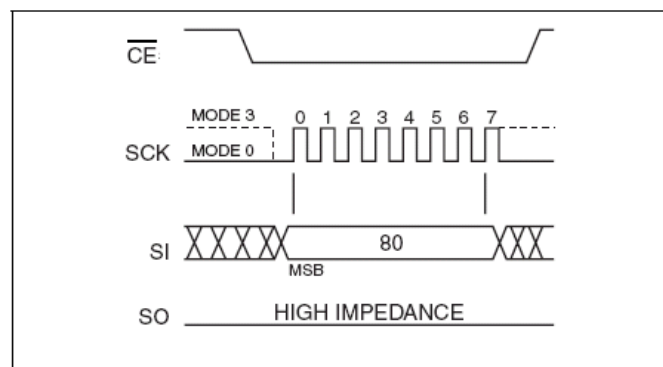

FIGURE 6 : DISABLE SO AS HARDWARE $\overline{RY}/\overline{BY}$ DURING AAI PROGRAMMING

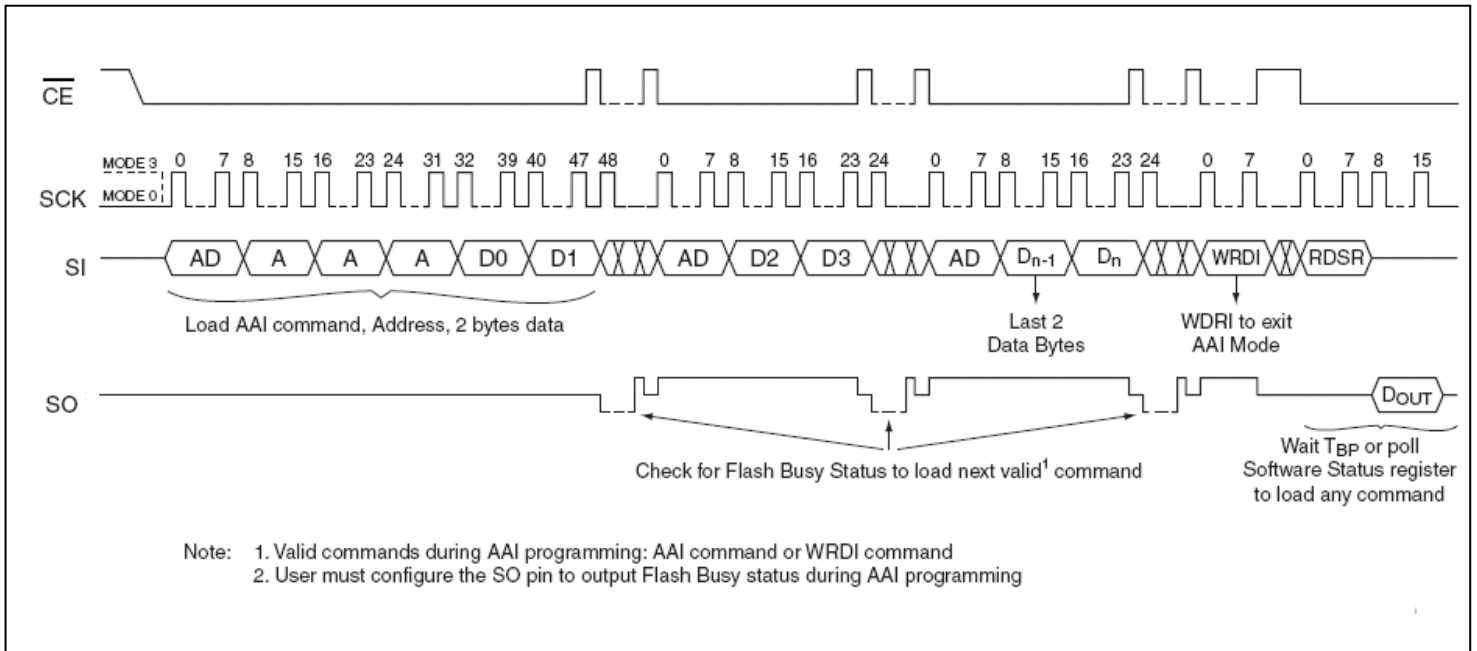

FIGURE 7 : AUTO ADDRESS INCREMENT (AAI) WORD-PROGRAM SEQUENCE WITH HARDWARE END-OF-WRITE DETECTION

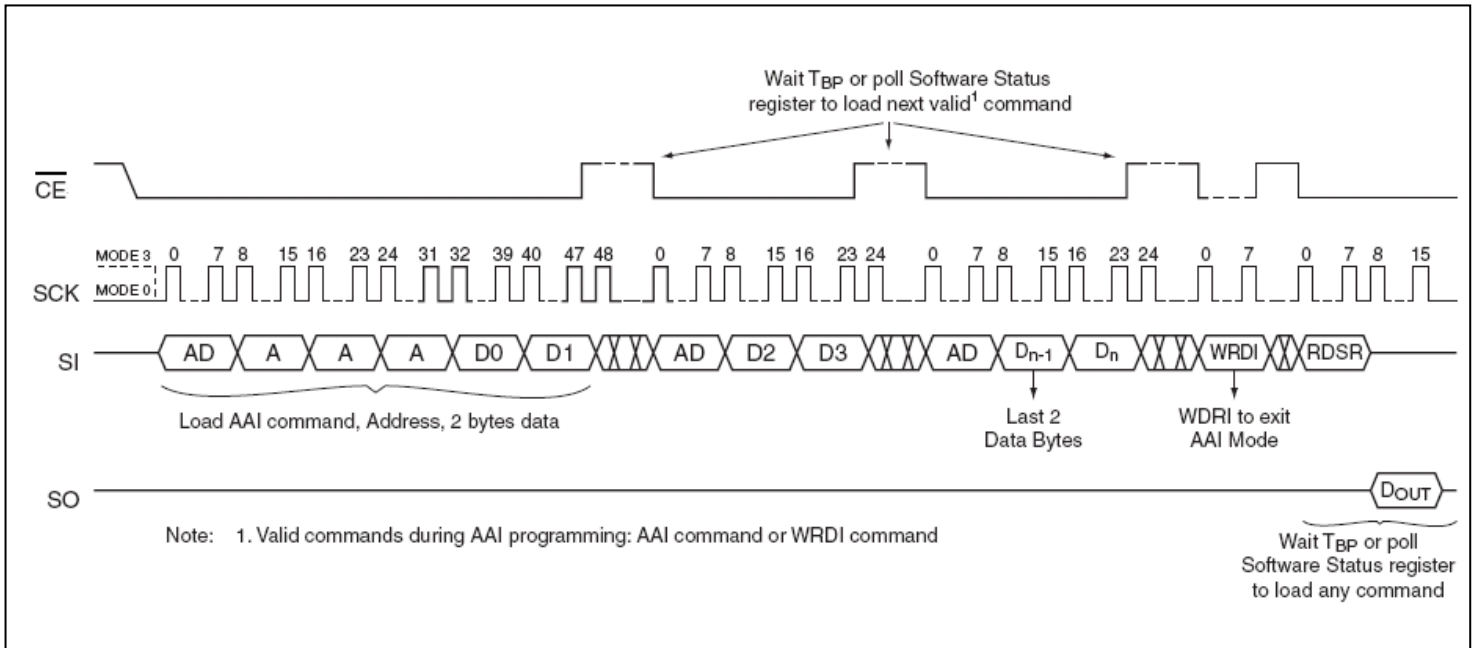

FIGURE 8 : AUTO ADDRESS INCREMENT (AAI) WORD-PROGRAM SEQUENCE WITH SOFTWARE END-OF-WRITE DETECTION

64K-Byte Block-Erase

The 64K Byte Block-Erase instruction clears all bits in the selected block to FFH. A Block-Erase instruction applied to a protected memory area will be ignored. Prior to any Write operation, the Write-Enable (WREN) instruction must be executed. \overline{CE} must remain active low for the duration of the any command sequence. The Block-Erase instruction is initiated by executing an 8-bit command, D8H, followed by address bits

[A₂₃-A₀]. Address bits [A_{MS}-A₁₆] (A_{MS} = Most Significant address) are used to determine the block address (BA_x), remaining address bits can be VIL or VIH. \overline{CE} must be driven high before the instruction is executed. The user may poll the Busy bit in the software status register or wait TBE for the completion of the internal self-timed Block-Erase cycle. See Figure 9 for the Block-Erase sequence.

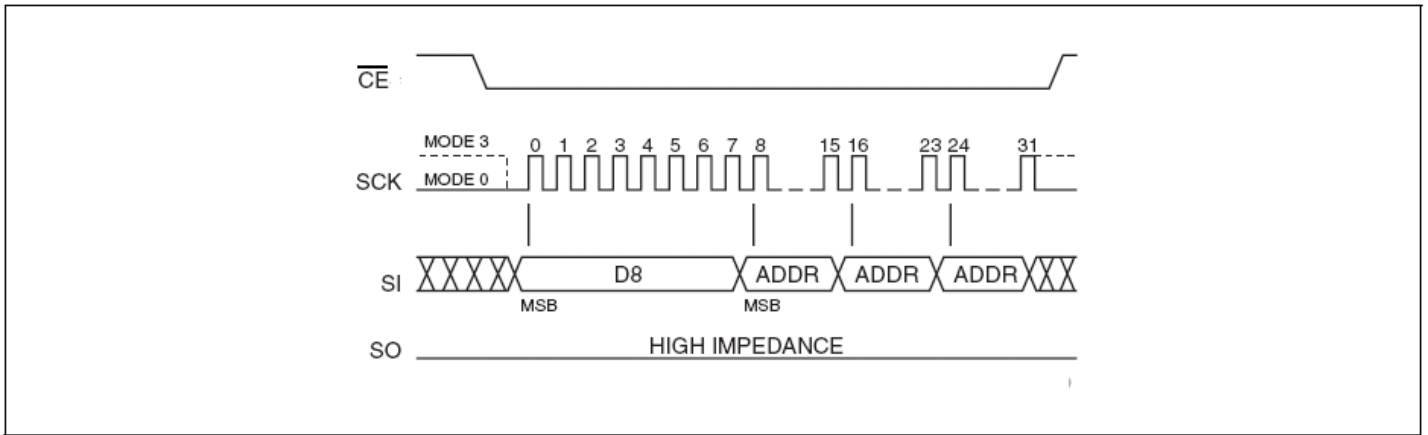

FIGURE 9 : 64-KBYTE BLOCK-ERASE SEQUENCE

4K-Byte-Sector-Erase

The Sector-Erase instruction clears all bits in the selected sector to FFH. A Sector-Erase instruction applied to a protected memory area will be ignored. Prior to any Write operation, the Write-Enable (WREN) instruction must be executed. \overline{CE} must remain active low for the duration of the any command sequence. The Sector-Erase instruction is initiated by executing an 8-bit command, 20H, followed by address bits [A₂₃-A₀]. Address bits

[A_{MS}-A₁₂] (A_{MS} = Most Significant address) are used to determine the sector address (SA_x), remaining address bits can be VIL or VIH. \overline{CE} must be driven high before the instruction is executed. The user may poll the Busy bit in the software status register or wait TSE for the completion of the internal self-timed Sector-Erase cycle. See Figure 10 for the Sector-Erase sequence.

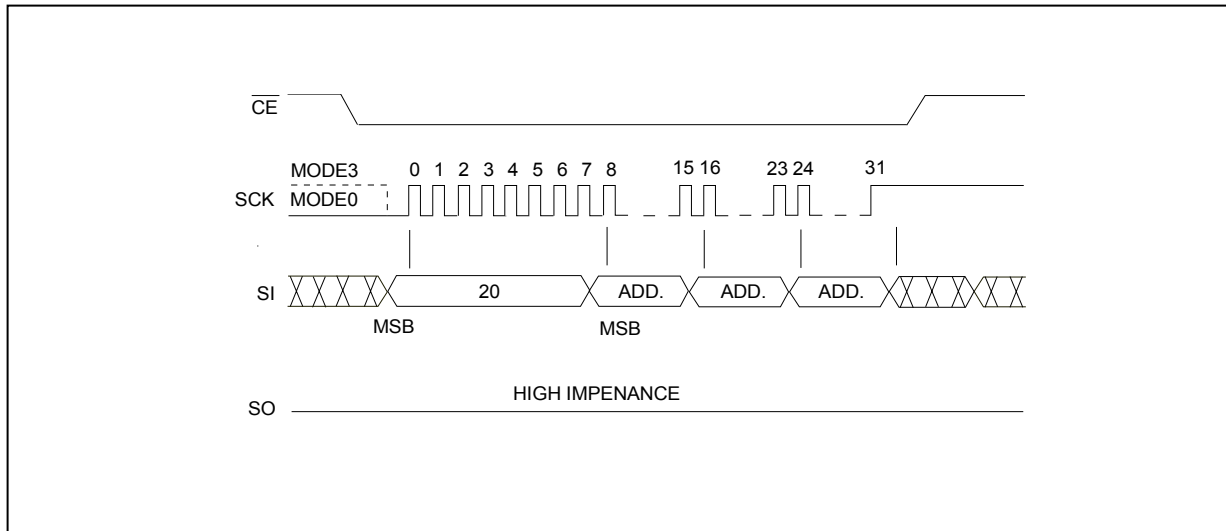

FIGURE 10 : SECTOR-ERASE SEQUENCE

Chip-Erase

The Chip-Erase instruction clears all bits in the device to FFH. A Chip-Erase instruction will be ignored if any of the memory area is protected. Prior to any Write operation, the Write-Enable (WREN) instruction must be executed. \overline{CE} must remain active low for the duration of the Chip-Erase instruction sequence. The Chip-Erase instruction is initiated by executing an 8-bit command,

60H or C7H. \overline{CE} must be driven high before the instruction is executed. The user may poll the Busy bit in the software status register or wait T_{CE} for the completion of the internal self-timed Chip-Erase cycle.

See Figure 11 for the Chip-Erase sequence.

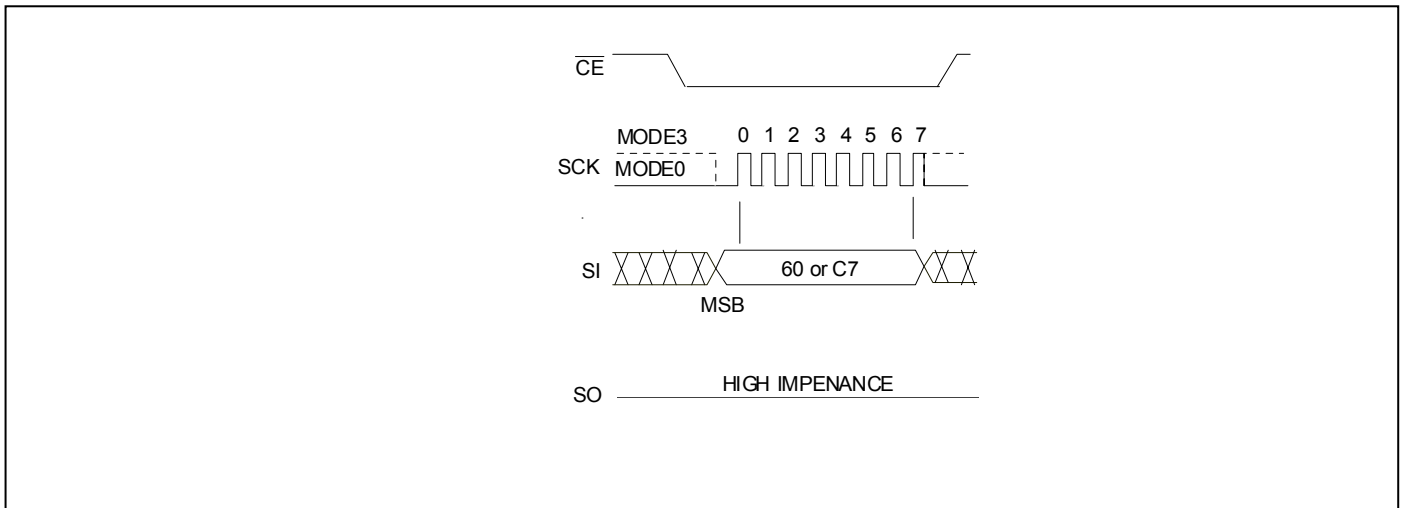

FIGURE 11 : CHIP-ERASE SEQUENCE

Read-Status-Register (RDSR)

The Read-Status-Register (RDSR) instruction allows reading of the status register. The status register may be read at any time even during a Write (Program/Erase) operation.

When a Write operation is in progress, the Busy bit may be checked before sending any new commands to assure that the new commands are properly received by the device.

\overline{CE} must be driven low before the RDSR instruction is entered

and remain low until the status data is read. Read-Status-Register is continuous with ongoing clock cycles until it is terminated by a low to high transition of the \overline{CE} . See Figure 12 for the RDSR instruction sequence.

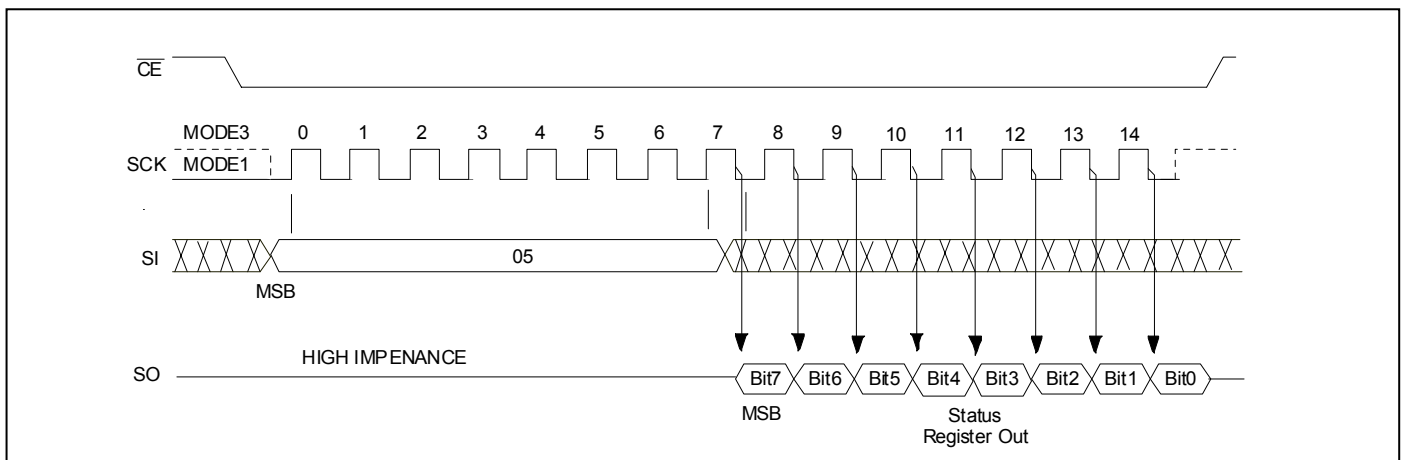

Figure12 : READ-STATUS-REGISTER (RDSR) SEQUENCE

Write-Enable (WREN)

The Write-Enable (WREN) instruction sets the Write-Enable-Latch bit to 1 allowing Write operations to occur. The WREN instruction must be executed prior to any Write (Program/Erase) operation. \overline{CE} must be driven high before the WREN instruction is executed.

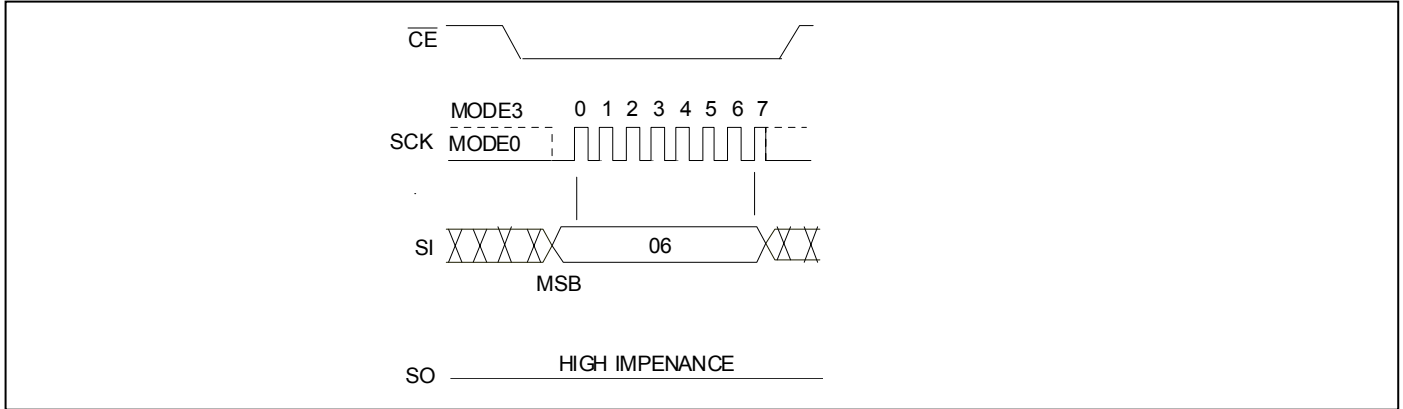

FIGURE 13 : WRITE ENABLE (WREN) SEQUENCE

Write-Disable (WRDI)

The Write-Disable (WRDI) instruction resets the Write-Enable-Latch bit and AAI bit to 0 disabling any new Write operations from occurring. \overline{CE} must be driven high before the WRDI instruction is executed.

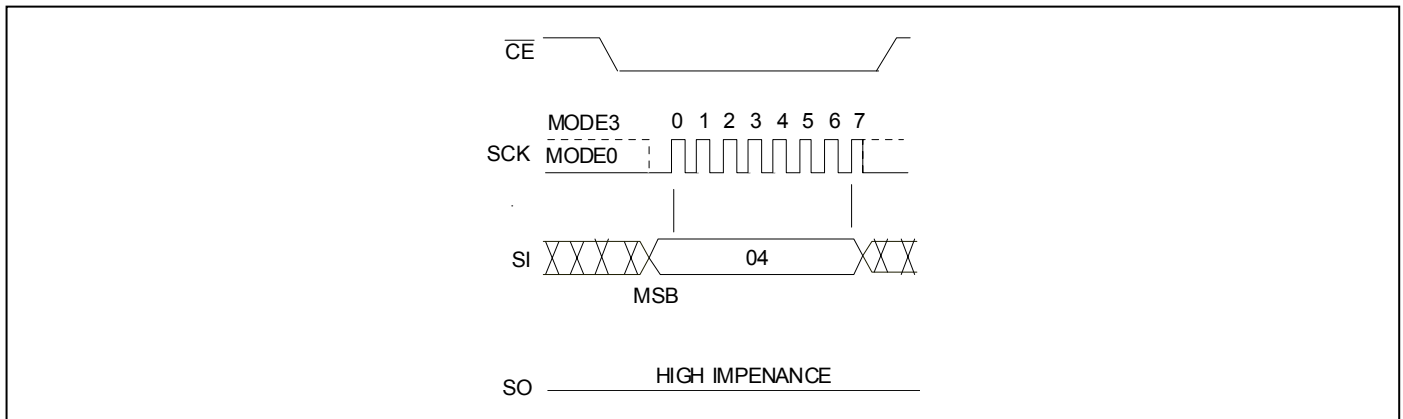

Figure 14 : WRITE DISABLE (WRDI) SEQUENCE

Enable-Write-Status-Register (EWSR)

The Enable-Write-Status-Register (EWSR) instruction arms the Write-Status-Register (WRSR) instruction and opens the status register for alteration. The Enable-Write-Status-Register instruction does not have any effect and will be wasted, if it is not followed immediately by the Write-Status-Register (WRSR) instruction. \overline{CE} must be driven low before the EWSR instruction is entered and must be driven high before the EWSR instruction is executed.

Write-Status-Register (WRSR)

The Write-Status-Register instruction writes new values to the BP2, BP1, BP0, and BPL bits of the status register. \overline{CE} must be driven low before the command sequence of the WRSR instruction is entered and driven high before the WRSR instruction is executed. See Figure 15 for EWSR or WREN and WRSR instruction sequences.

Executing the Write-Status-Register instruction will be ignored when \overline{WP} is low and BPL bit is set to "1". When the \overline{WP} is low, the BPL bit can only be set from "0" to "1" to lockdown the status register, but cannot be reset from "1" to "0".

When \overline{WP} is high, the lock-down function of the BPL bit is disabled and the BPL, BP0, BP1, and BP2 bits in the status register can all be changed. As long as BPL bit is set to 0 or \overline{WP} pin is driven high (V_{IH}) prior to the low-to-high transition of the \overline{CE} pin at the end of the WRSR instruction, the bits in the status register can all be altered by the WRSR instruction. In this case, a single WRSR instruction can set the BPL bit to "1" to lock down the status register as well as altering the BP0, BP1 and BP2 bits at the same time. See Table 3 for a summary description of \overline{WP} and BPL functions.

Figure 15 : ENABLE-WRITE-STATUS-REGISTER (EWSR) or WRITE-ENABLE(WREN) and WRITE-STATUS-REGISTER (WRSR)

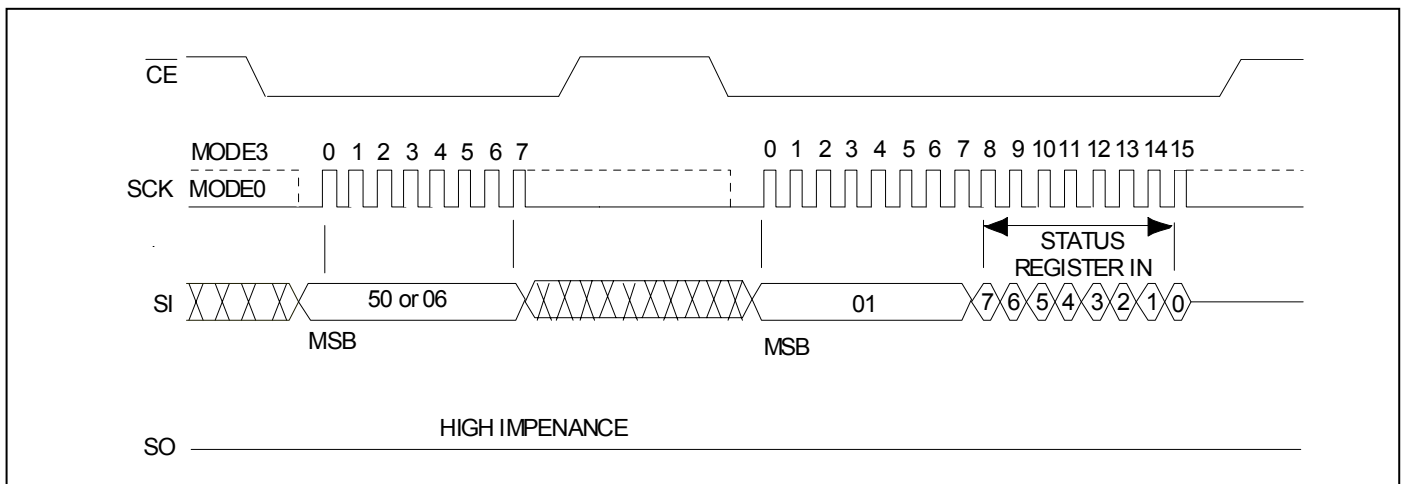

Read-Electronic-Signature (RES)

The RES instruction can be used to read the 8-bit Electronic Signature of the device on the SO pin. The RES instruction can provide access to the Electronic Signature of the device (except while an Erase, Program or WRSR cycle is in progress), Any ERS instruction executed while an Erase, Program or WRSR cycle is in progress is no decoded, and has no effect on the cycle in progress.

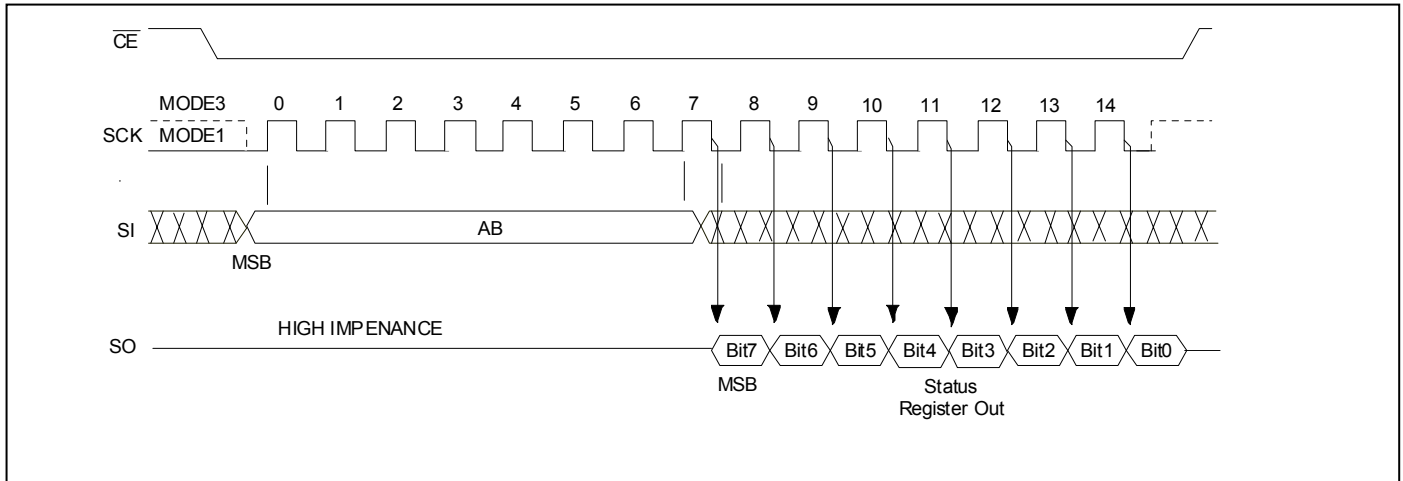

Figure 16 : Read-Electronic-Signature (RES)

JEDEC Read-ID

The JEDEC Read-ID instruction identifies the device as F25L004A and the manufacturer as ESMT. The device information can be read from executing the 8-bit command, 9FH. Following the JEDEC Read-ID instruction, the 8-bit manufacturer's ID, 8CH, is output from the device. After that, a 16-bit device ID is shifted out on the SO pin. Byte1, 8CH, identifies the manufacturer as ESMT. Byte2, 20H, identifies the memory type as SPI Flash. Byte3, 13H, identifies the device as F25L004A. The instruction sequence is shown in Figure17. The JEDEC Read ID instruction is terminated by a low to high transition on \overline{CE} at any time during data output. If no other command is issued after executing the JEDEC Read-ID instruction, issue a 00H (NOP) command before going into Standby Mode ($\overline{CE} = V_{IH}$).

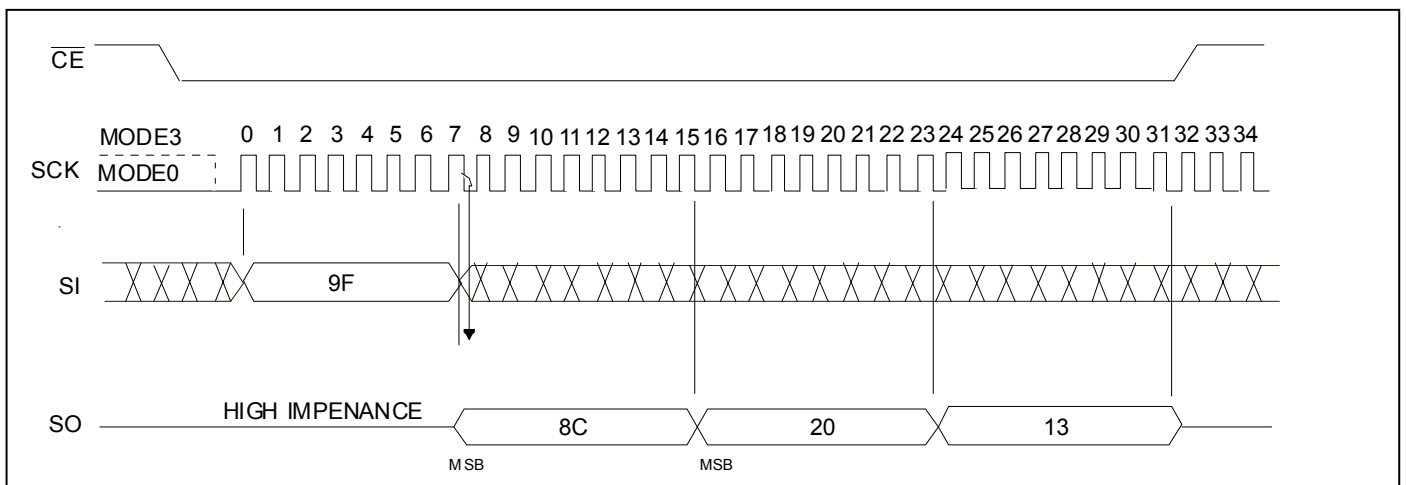

Figure 17 : Jedec Read ID Sequence

Table 9 : JEDEC READ-ID DATA

Manufacturer's ID	Device ID	
	Memory Type	Memory Capacity
Byte1	Byte 2	Byte 3
8CH	20H	13H

Read-ID (RDID)

The Read-ID instruction (RDID) identifies the devices as F25L004A and manufacturer as ESMT. This command is backward compatible to all ESMT SPI devices and should be used as default device identification when multiple versions of ESMT SPI devices are used in one design. The device information can be read from executing an 8-bit command, 90H or ABH, followed by address bits [A₂₃-A₀]. Following the Read-ID instruction, the manufacturer's ID is located in address 00000H and the device ID is located in address 00001H. Once the device is in Read-ID mode, the manufacturer's and device ID output data toggles between address 00000H and 00001H until terminated by a low to high transition on \overline{CE} .

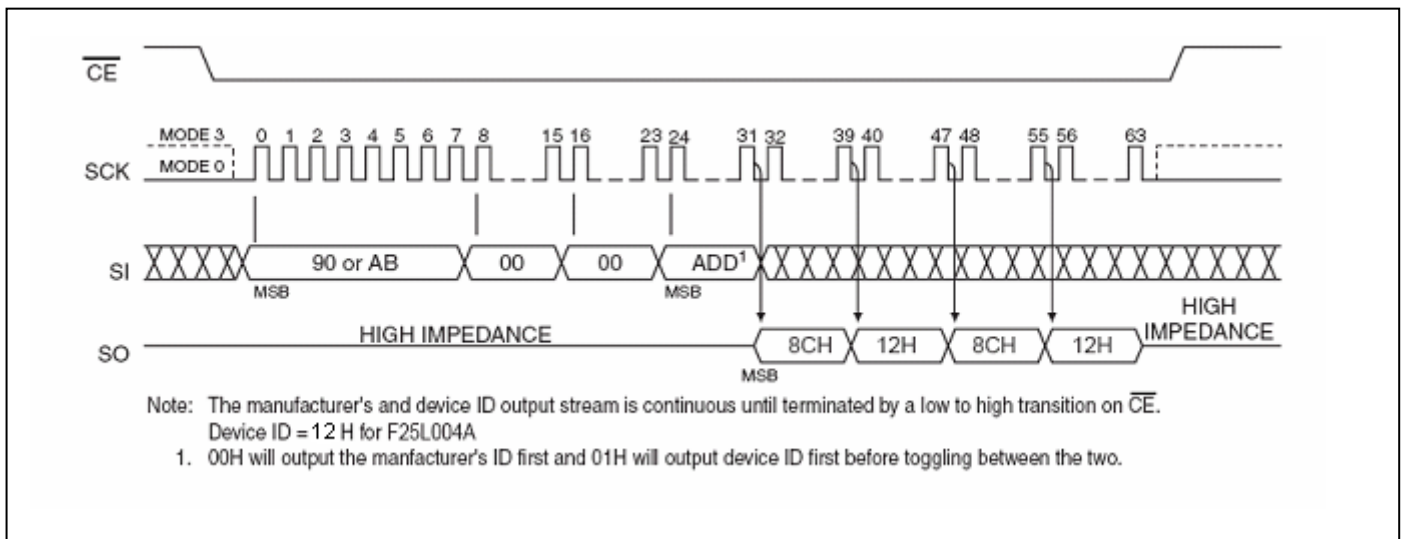

Figure 18 : Read-Electronic-Signature

Table 10 : JEDEC READ-ID DATA

	Address	Byte1	Byte2
Manufacturer's ID	00000H	8CH	12H
Device ID ESMT F25L004A	00001H	12H	8CH

ELECTRICAL SPECIFICATIONS

Absolute Maximum Stress Ratings

(Applied conditions greater than those listed under “Absolute Maximum Stress Ratings” may cause permanent damage to the device. This is a stress rating only and functional operation of the device at these conditions or conditions greater than those defined in the operational sections of this data sheet is not implied. Exposure to absolute maximum stress rating conditions may affect device reliability.)

Storage Temperature	-65°C to +150°C
D. C. Voltage on Any Pin to Ground Potential	-0.5V to VDD+0.5V
Transient Voltage (<20 ns) on Any Pin to Ground Potential	-2.0V to VDD+2.0V
Package Power Dissipation Capability (Ta = 25°C)	1.0W
Surface Mount Lead Soldering Temperature (3 Seconds)	240°C
Output Short Circuit Current(Note1)	50 mA

Note :

1. Output shorted for no more than one second. No more than one output shorted at a time.

AC CONDITIONS OF TEST

Input Rise/Fall Time	< 5 ns
Output Load	CL = 15 pF for ≥ 75MHz
	CL = 30 pF for ≤ 50MHz
See Figures 23 and 24	

OPERATING RANGE

Parameter	Symbol	Value	Unit
Operating Supply Voltage	VDD (for FCLK ≤ 75MHz)	2.7~3.6	V
	VDD (for FCLK = 100MHz)	3.0~3.6	
Ambient Operating Temperature	TA	0~70	°C

TABLE 6: DC OPERATING CHARACTERISTICS

Symbol	Parameter	Limits			Test Conditions
		Min	Max	Units	
IDDR	Read Current		15	mA	CE = 0.1 VDD/0.9 VDD @ 33 MHz, SO=open
IDDW	Program and Erase Current		40	mA	CE = VDD
ISB	Standby Current		75	µA	CE = VDD, VIN = VDD or VSS
ILI	Input Leakage Current		1	µA	VIN = GND to VDD, VDD = VDD Max
ILO	Output Leakage Current		1	µA	VOU = GND to VDD, VDD = VDD Max
VIL	Input Low Voltage		0.8	V	VDD = VDD Min
VIH	Input High Voltage	0.7 VDD		V	VDD = VDD Max
VOL	Output Low Voltage		0.2	V	IOL = 100 µA, VDD = VDD Min
VOH	Output High Voltage	VDD - 0.2		V	IOH = -100 µA, VDD = VDD Min

TABLE 7 : RECOMMENDED SYSTEM POWER-UP TIMINGS

Symbol	Parameter	Minimum	Units
T _{PU-READ} ¹	VDD Min to Read Operation	10	µs
T _{PU-WRITE} ¹	VDD Min to Write Operation	10	µs

1. This parameter is measured only for initial qualification and after a design or process change that could affect this parameter.

TABLE 8: CAPACITANCE (T_A = 25°C, f=1 Mhz, other pins open)

Parameter	Description	Test Condition	Maximum
C _{OUT} ¹	Output Pin Capacitance	V _{OUT} = 0V	12 pF
C _{IN} ¹	Input Capacitance	V _{IN} = 0V	6 pF

1. This parameter is measured only for initial qualification and after a design or process change that could affect this parameter.

TABLE 11: RELIABILITY CHARACTERISTICS

Symbol	Parameter	Minimum Specification	Units	Test Method
N _{END} ¹	Endurance	100,000	Cycles	JEDEC Standard A117
T _{DR} ¹	Data Retention	10	Years	JEDEC Standard A103
I _{LTH} ¹	Latch Up	100 + IDD	mA	JEDEC Standard 78

1. This parameter is measured only for initial qualification and after a design or process change that could affect this parameter.

TABLE 12 : AC OPERATING CHARACTERISTICS

Symbol	Parameter	Normal 33MHz		Fast 50 MHz		Fast 100 MHz		Units
		Min	Max	Min	Max	Min	Max	
F _{CLK}	Serial Clock Frequency		33		50		100	MHz
T _{SCKH}	Serial Clock High Time	13		9		5		ns
T _{SCKL}	Serial Clock Low Time	13		9		5		ns
T _{CES} ¹	\overline{CE} Active Setup Time	5		5		5		ns
T _{CEH} ¹	\overline{CE} Active Hold Time	5		5		5		ns
T _{CHS} ¹	\overline{CE} Not Active Setup Time	5		5		5		ns
T _{CHH} ¹	\overline{CE} Not Active Hold Time	5		5		5		ns
T _{CPH}	\overline{CE} High Time	100		100		100		ns
T _{CHZ}	\overline{CE} High to High-Z Output		9		9		9	ns
T _{CLZ}	SCK Low to Low-Z Output	0		0		0		ns
T _{DS}	Data In Setup Time	3		3		3		ns
T _{DH}	Data In Hold Time	3		3		3		ns
T _{HLS}	\overline{HOLD} Low Setup Time	5		5		5		ns
T _{HHS}	\overline{HOLD} High Setup Time	5		5		5		ns
T _{HLH}	\overline{HOLD} Low Hold Time	5		5		5		ns
T _{HHH}	\overline{HOLD} High Hold Time	5		5		5		ns
T _{HZ}	\overline{HOLD} Low to High-Z Output		9		9		9	ns
T _{LZ}	\overline{HOLD} High to Low-Z Output		9		9		9	ns
T _{OH}	Output Hold from SCK Change	0		0		0		ns
T _V	Output Valid from SCK		12		8		7	ns

1. Relative to SCK.

ERASE AND PROGRAMMING PERFORMANCE

Parameter	Symbol	Limits		Unit
		Typ.(2)	Max.(3)	
Sector Erase Time	T_{SE}	90	200	ms
Block Erase Time	T_{BE}	1	2	s
Chip Erase Time	T_{CE}	4	30	s
Byte Programming Time	T_{BP}	7	30	us
Chip Programming Time		12	100	s
Erase/Program Cycles (1)		100,000	-	Cycles
Data Retention		20	-	Years

Notes:

1. Not 100% Tested, Excludes external system level over head.
2. Typical values measured at 25°C, 3V.
3. Maximum values measured at 85°C, $V_{DD(min)}$.

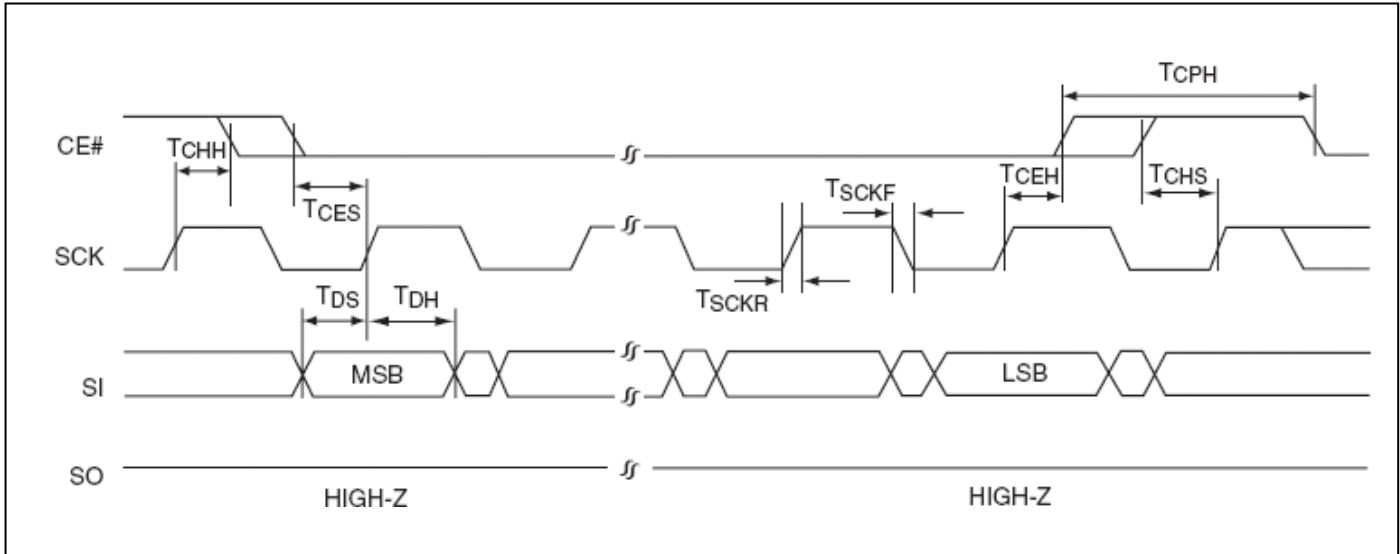

FIGURE 19: SERIAL INPUT TIMING DIAGRAM

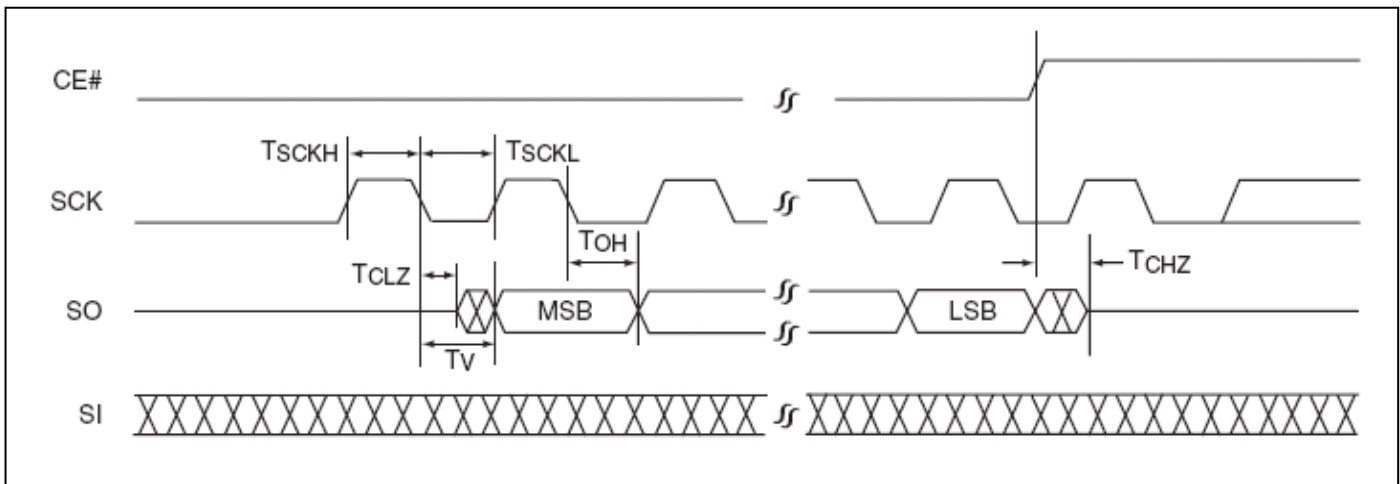

FIGURE 20: SERIAL OUTPUT TIMING DIAGRAM

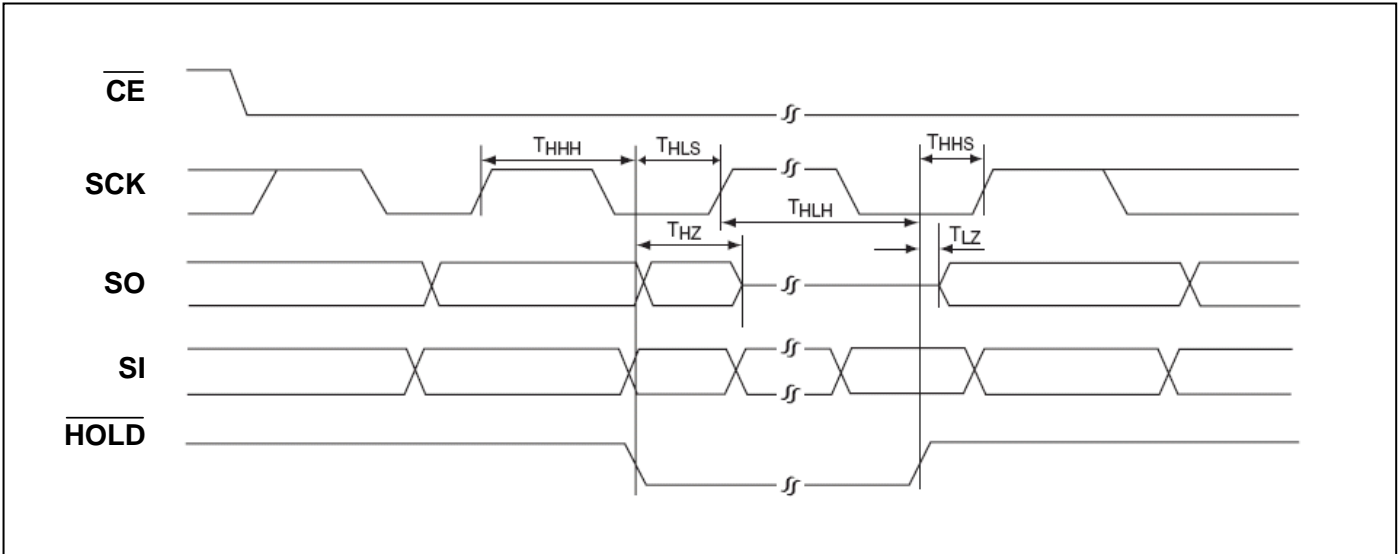

FIGURE 21: HOLD TIMING DIAGRAM

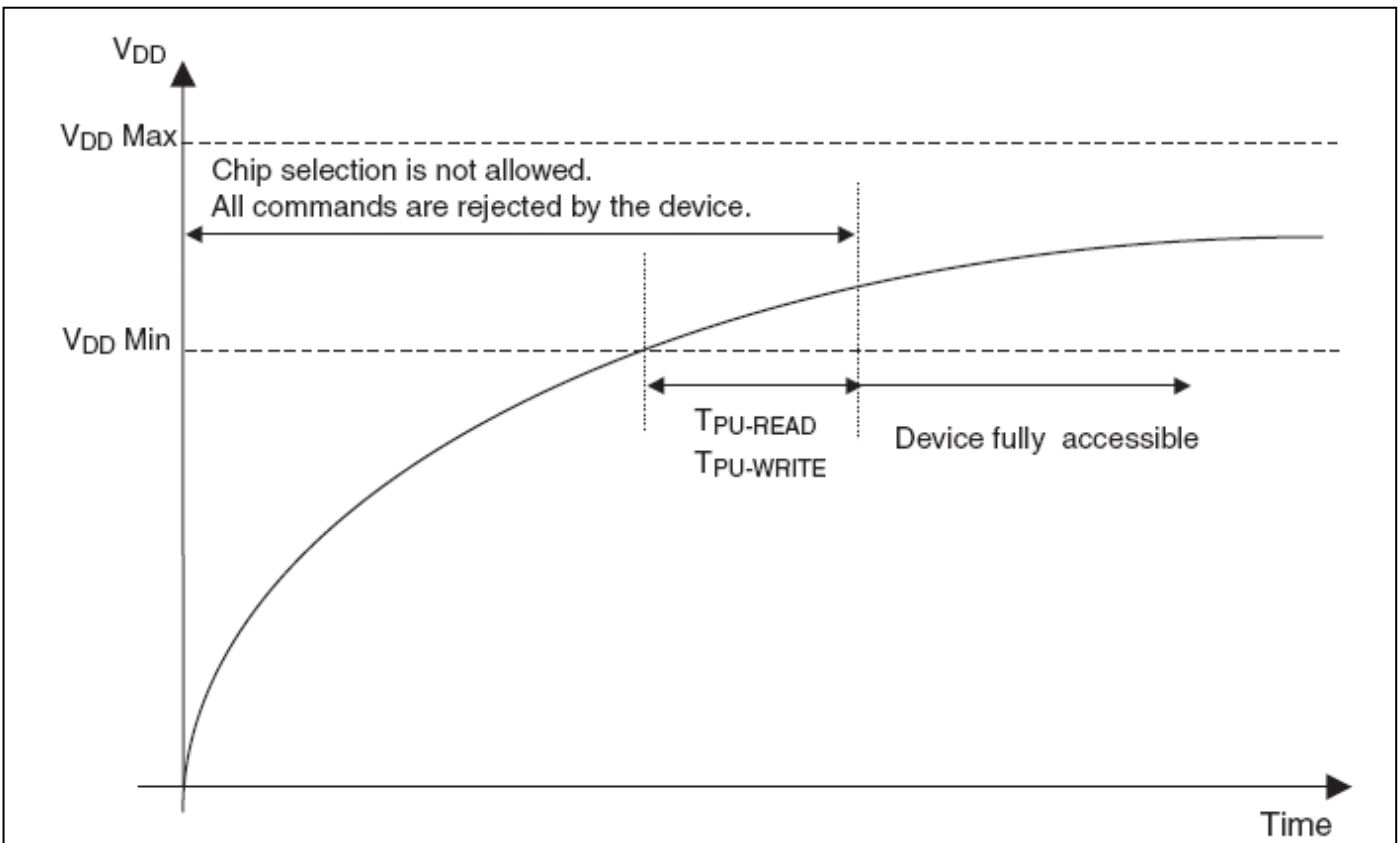

FIGURE 22: POWER-UP TIMING DIAGRAM

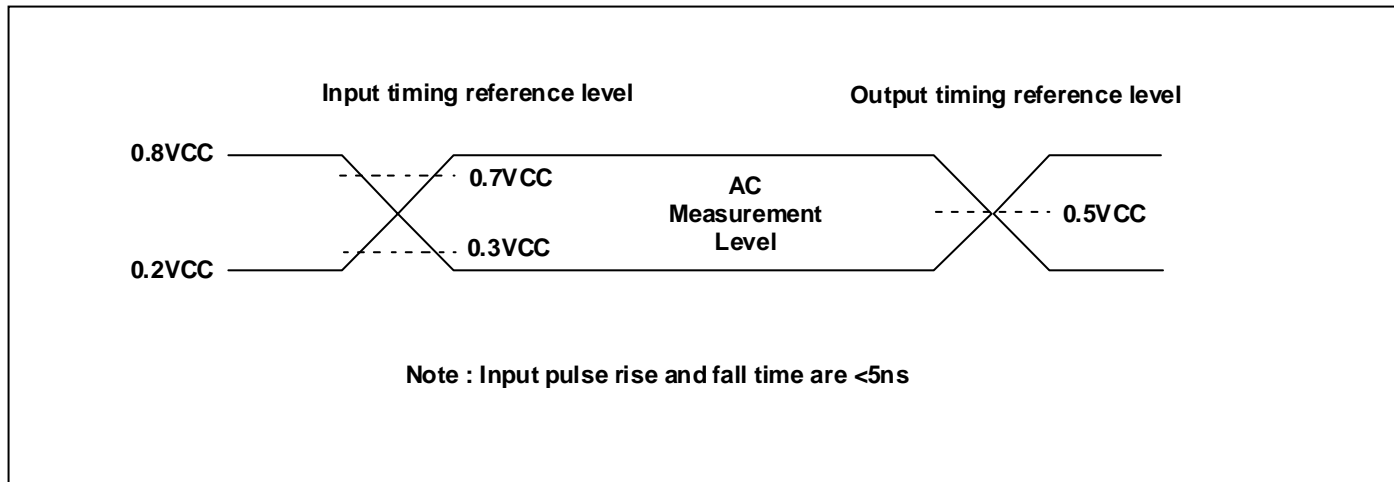

FIGURE 23 : AC INPUT/OUTPUT REFERENCE WAVEFORMS

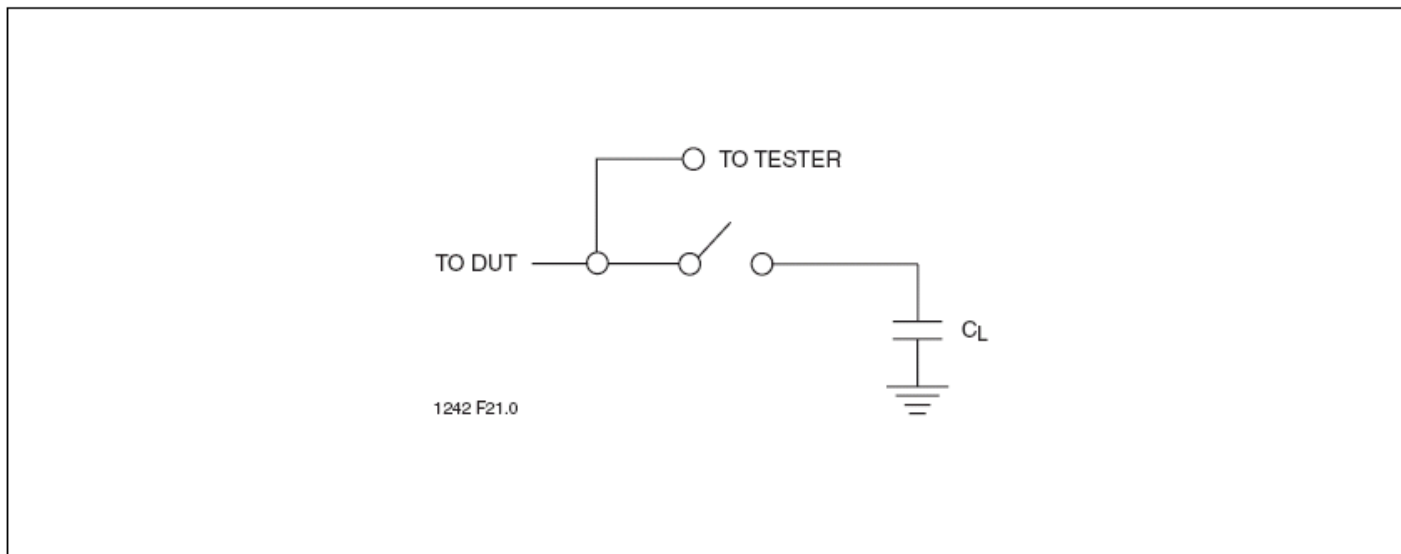
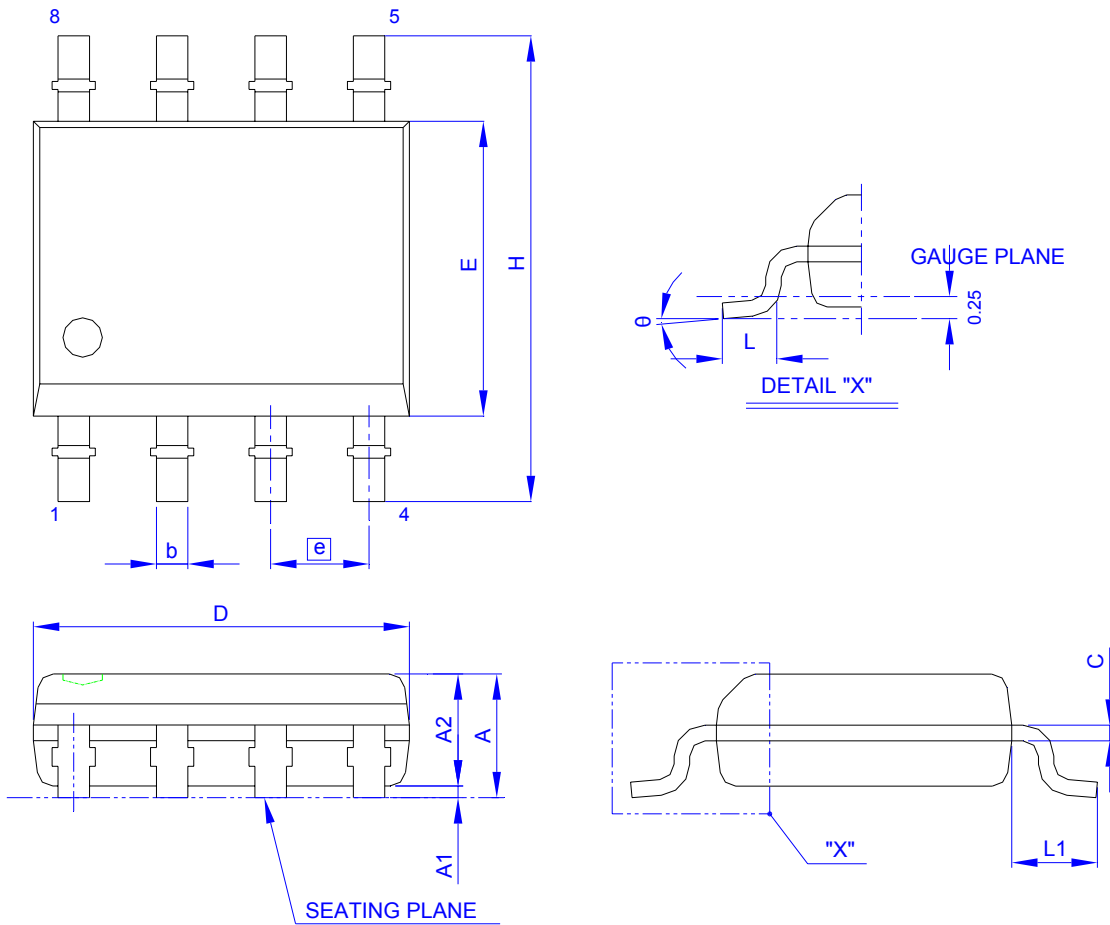

FIGURE 24: A TEST LOAD EXAMPLE

PACKAGING DIAGRAMS

8-LEAD SOIC (150 mil)



Symbol	Dimension in mm			Dimension in inch			Symbol	Dimension in mm			Dimension in inch		
	Min	Norm	Max	Min	Norm	Max		Min	Norm	Max	Min	Norm	Max
A	1.35	1.60	1.75	0.053	0.063	0.069	D	4.80	4.90	5.00	0.189	0.193	0.197
A ₁	0.10	0.15	0.25	0.004	0.006	0.010	E	3.80	3.90	4.00	0.150	0.154	0.157
A ₂	1.25	1.45	1.55	0.049	0.057	0.061	L	0.40	0.66	1.27	0.016	0.026	0.050
b	0.33	0.406	0.51	0.013	0.016	0.020	e	1.27 BSC			0.050 BSC		
c	0.19	0.203	0.25	0.0075	0.008	0.010	L ₁	1.00	1.05	1.10	0.039	0.041	0.043
H	5.80	6.00	6.20	0.228	0.236	0.244	θ	0°	---	8°	0°	---	8°

Controlling dimension : millimeter

PACKING DIMENSIONS

8-LEAD SOIC 200 mil (official name - 209 mil)

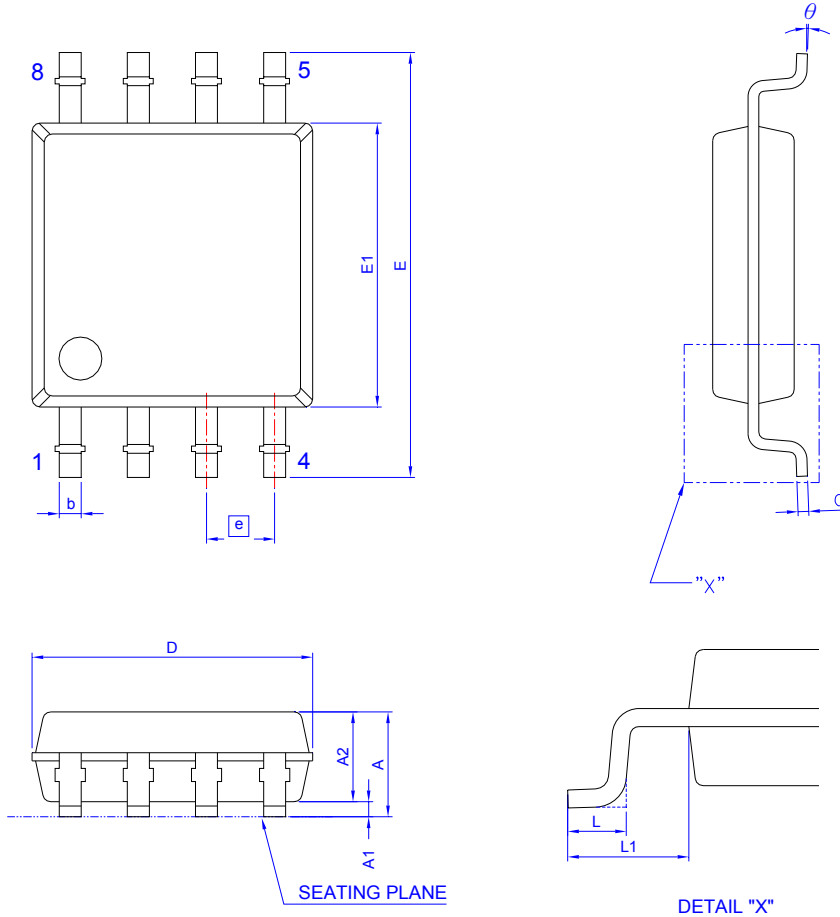

Symbol	Dimension in mm			Dimension in inch			Symbol	Dimension in mm			Dimension in inch		
	Min	Norm	Max	Min	Norm	Max		Min	Norm	Max	Min	Norm	Max
A	---	---	2.16	---	---	0.085	E	7.70	7.90	8.10	0.303	0.311	0.319
A ₁	0.05	0.15	0.25	0.002	0.006	0.010	E ₁	5.18	5.28	5.38	0.204	0.208	0.212
A ₂	1.70	1.80	1.91	0.067	0.071	0.075	L	0.50	0.65	0.80	0.020	0.026	0.032
b	0.36	0.41	0.51	0.014	0.016	0.020	\square e	1.27 BSC			0.050 BSC		
c	0.19	0.20	0.25	0.007	0.008	0.010	L ₁	1.27	1.37	1.47	0.050	0.054	0.058
D	5.13	5.23	5.33	0.202	0.206	0.210	θ	0°	---	8°	0°	---	8°

Controlling dimension : millimeter

PACKAGING DIAGRAMS

8-LEAD SOIC (150 mil)

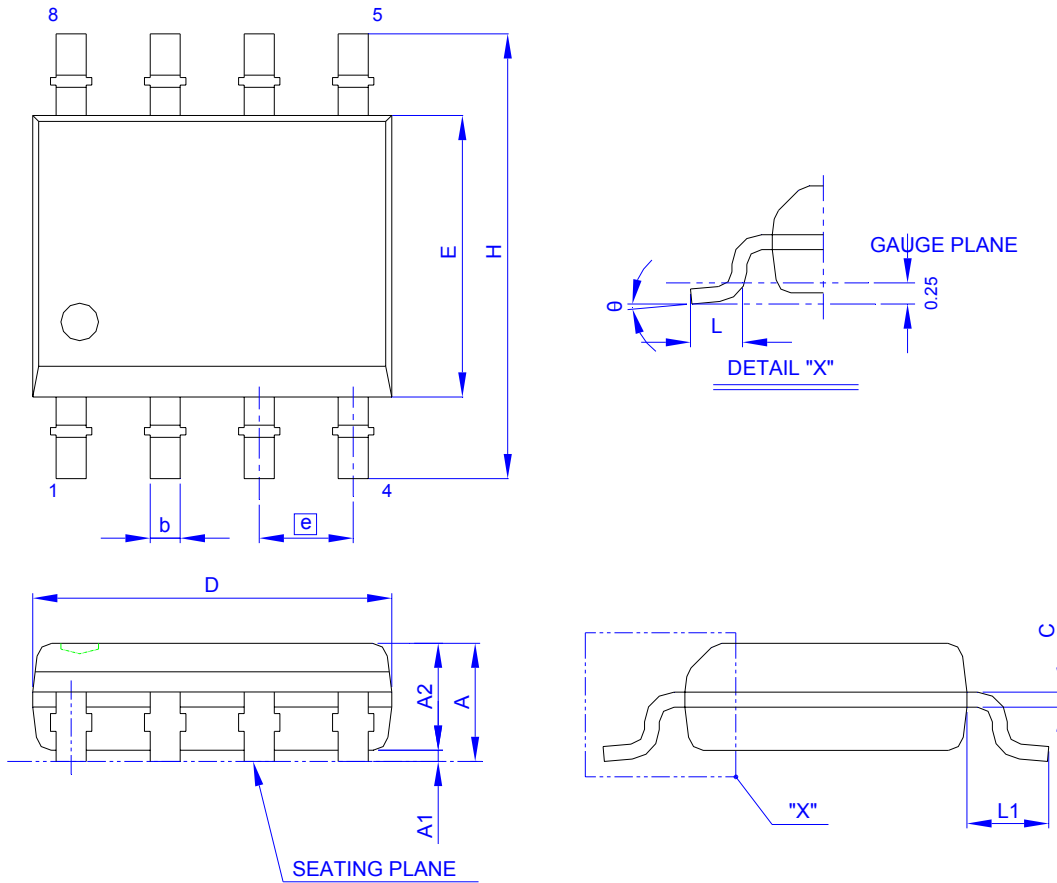

Symbol	Dimension in mm			Dimension in inch			Symbol	Dimension in mm			Dimension in inch		
	Min	Norm	Max	Min	Norm	Max		Min	Norm	Max	Min	Norm	Max
A	1.35	1.60	1.75	0.053	0.063	0.069	D	4.80	4.90	5.00	0.189	0.193	0.197
A ₁	0.10	0.15	0.25	0.004	0.006	0.010	E	3.80	3.90	4.00	0.150	0.154	0.157
A ₂	1.25	1.45	1.55	0.049	0.057	0.061	L	0.40	0.66	0.86	0.016	0.026	0.034
b	0.33	0.406	0.51	0.013	0.016	0.020	e	1.27 BSC			0.050 BSC		
c	0.19	0.203	0.25	0.0075	0.008	0.010	L ₁	1.00	1.05	1.10	0.039	0.041	0.043
H	5.80	6.00	6.20	0.228	0.236	0.244	θ	0°	---	8°	0°	---	8°

Controlling dimension : millimeter

Revision History

Revision	Date	Description
1.0	2006.09.27	Original
1.1	2006.11.28	1. Add AAI function. 2. Delete speed grade 75MHz. 3. Modify ISB spec.
1.2	2007.03.06	Correct Ordering Information from F25L004A-50P to F25L004A-50D
1.3	2007.04.04	1. Correct Byte Program Time. 2. Modify ordering information.
1.4	2008.07.17	1. Add "All Pb-free products are RoHS-Compliant" in the description of features 2. Delete bottom block protection table 3. Modify tSE timing 4. Add Revision History
1.5	2008.12.10	1. Add operating range table 2. Delete the rating of Temperature Under Bias 3. Add the symbol for erase and byte programming time 4. Correct typo error
1.6	2009.01.12	1. Correct the size of "L" in the packaging diagram of SOIC 150mil 2. Modify headline

Important Notice

All rights reserved.

No part of this document may be reproduced or duplicated in any form or by any means without the prior permission of ESMT.

The contents contained in this document are believed to be accurate at the time of publication. ESMT assumes no responsibility for any error in this document, and reserves the right to change the products or specification in this document without notice.

The information contained herein is presented only as a guide or examples for the application of our products. No responsibility is assumed by ESMT for any infringement of patents, copyrights, or other intellectual property rights of third parties which may result from its use. No license, either express, implied or otherwise, is granted under any patents, copyrights or other intellectual property rights of ESMT or others.

Any semiconductor devices may have inherently a certain rate of failure. To minimize risks associated with customer's application, adequate design and operating safeguards against injury, damage, or loss from such failure, should be provided by the customer when making application designs.

ESMT's products are not authorized for use in critical applications such as, but not limited to, life support devices or system, where failure or abnormal operation may directly affect human lives or cause physical injury or property damage. If products described here are to be used for such kinds of application, purchaser must do its own quality assurance testing appropriate to such applications.