

Features

- Small Size and Low Profile
- Superior Repeatability
- Passbands 824 – 960 MHz and 1850 – 1990 MHz
- Passbands 880 – 960 MHz and 1700 – 1900 MHz
- Typical Passband Insertion Loss: 0.5 dB
- 2 Watt Power Handling
- Low Cost
- SOIC-8 Package

Description

M/A-COM's DP52-0002 is an IC-based monolithic diplexer in a low cost SOIC-8 SMT plastic package. This diplexer is ideally suited for applications where small size, low insertion loss, superior repeatability, and low cost are required. Typical applications include AMPS/PCS and GSM/DCS dual mode portable devices.

The DP52-0002 is fabricated using a passive-integrated circuit process. The process features full-chip passivation for increased performance and reliability.

Functional Block Diagram^{1,2}

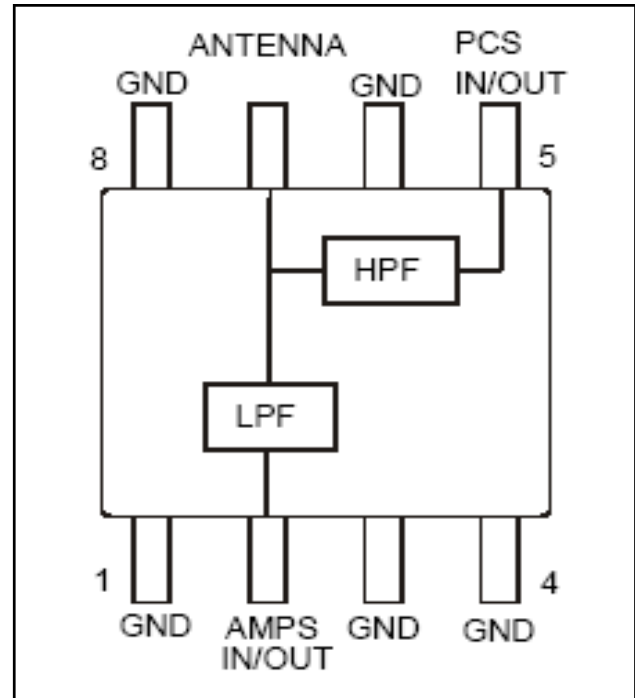

1. All unused pins must be RF and DC grounded.
2. Pins 1 and 4 are thermal ground contacts.

Ordering Information

Part Number	Package
DP52-0002	Bulk Packaging
DP52-0002-TR	1000 piece reel
DP52-0002SAM	Sample Test Board

Note: Reference Application Note M513 for reel size information.

Pin Configuration

Pin No.	Function	Pin No.	Function
1	GND	5	PCS IN/OUT
2	AMPS IN/OUT	6	GND
3	GND	7	ANTENNA
4	GND	8	GND

824 – 960 / 1850 – 1990 MHz Electrical Specifications: $T_A = 25^\circ\text{C}$, $Z_0 = 50\Omega$

Parameter	Units	Min	Typ	Max
Passband Insertion Loss	dB	—	0.5	0.8
Stopband Isolation	dB	12	18	—
Passband VSWR	—	—	1.4:1	1.7:1

880 – 960 / 1700 – 1900 MHz Electrical Specifications: $T_A = 25^\circ\text{C}$, $Z_0 = 50\Omega$

Parameter	Units	Min	Typ	Max
Passband Insertion Loss	dB	—	0.5	0.9
Stopband Isolation	dB	12	18	—
Passband VSWR	—	—	1.5:1	1.8:1

Absolute Maximum Ratings ^{3,4}

Parameter	Absolute Maximum
Input Power	2W CW
Operating Temperature	-40°C to +85°C
Storage Temperature	-65°C to +150°C

- Exceeding any one or combination of these limits may cause permanent damage to this device.
- M/A-COM does not recommend sustained operation near these survivability limits.

Handling Procedures

Please observe the following precautions to avoid damage:

Static Sensitivity

GMIC Circuits are sensitive to electrostatic discharge (ESD) and can be damaged by static electricity. Proper ESD control techniques should be used when handling these devices.

Recommended PCB Configuration

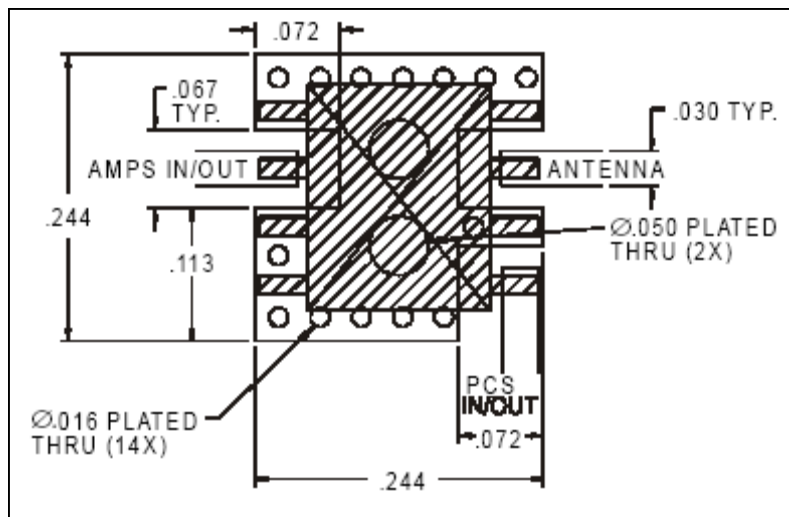

Typical Performance Curves

Insertion Loss vs. Frequency

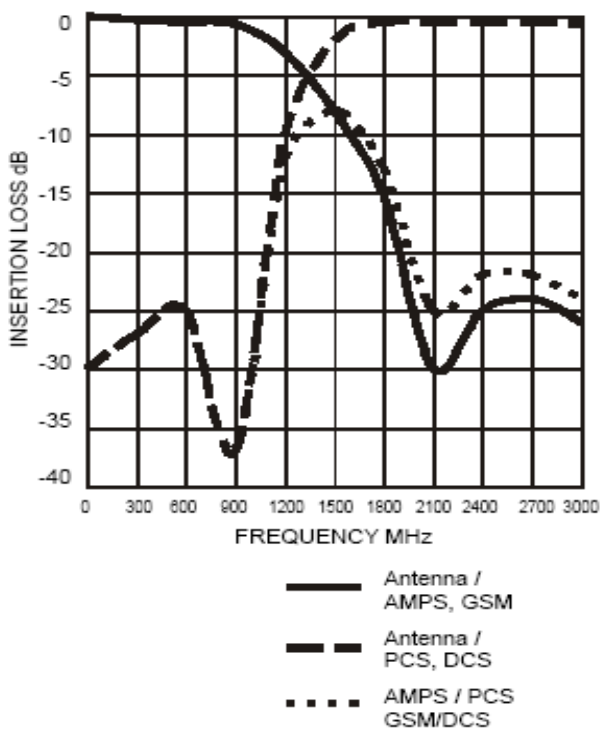

VSWR vs. Frequency

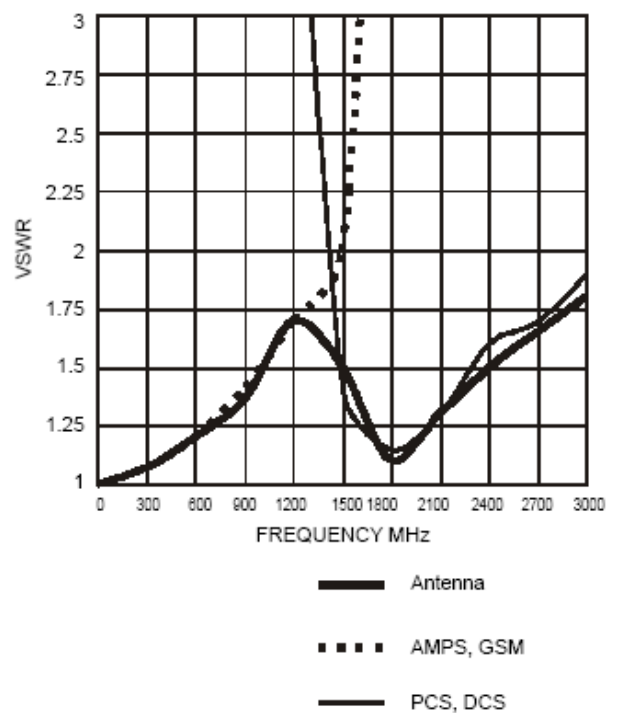

SOIC-8[†]

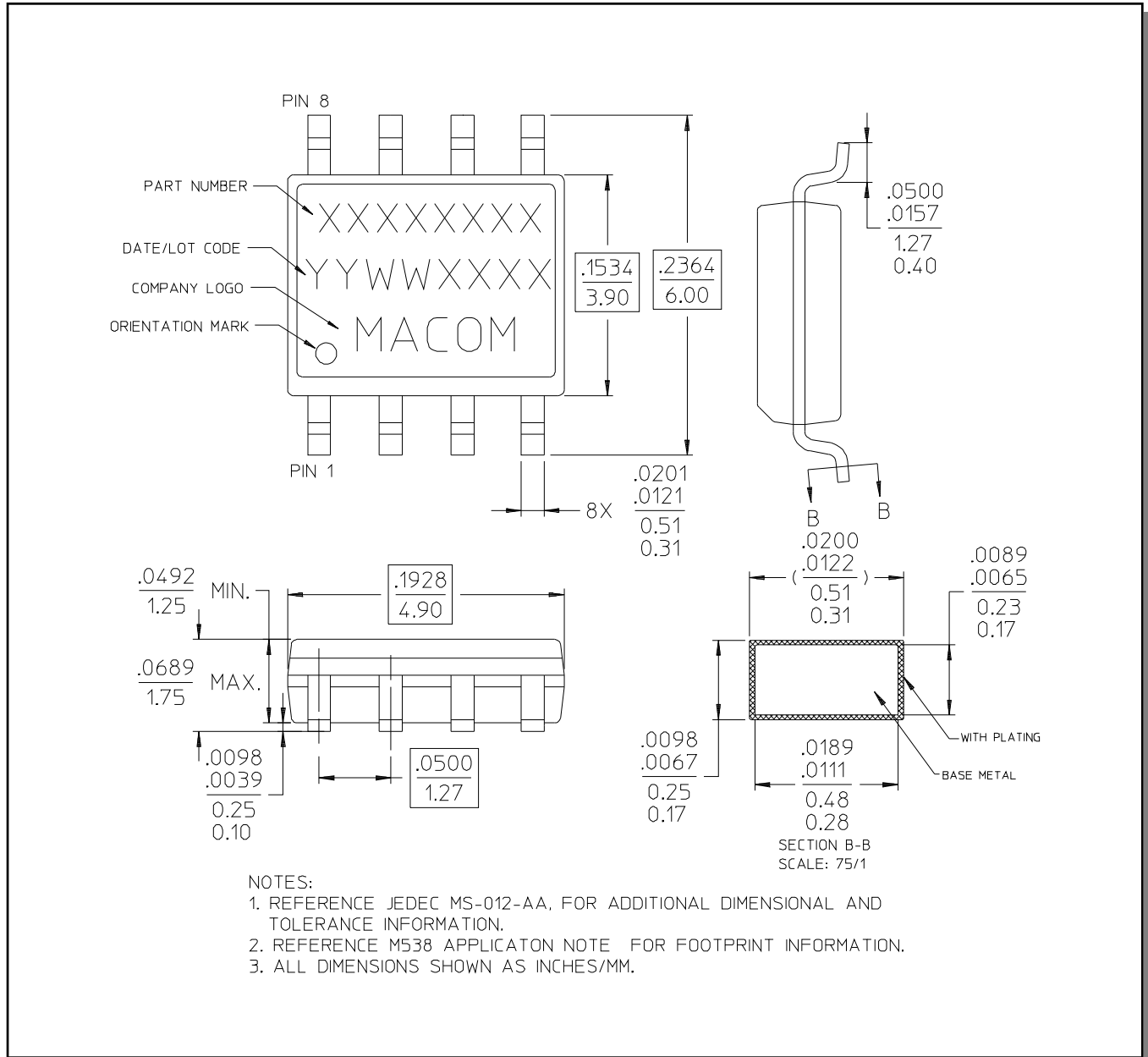

[†] Reference Application Note M538 for lead-free solder reflow recommendations.