

512K x 8 FLASH

UNIFORM SECTOR 5.0V FLASH MEMORY

**AVAILABLE AS MILITARY
SPECIFICATIONS**

- MIL-STD-883
- SMD 5962-96692

FEATURES

- Single 5.0V ±10% power supply operation
- Fastest access times: 55, 60, 70, 90, 120, & 150ns
- Low power consumption:
 - ✓ 20 mA typical active read current
 - ✓ 30 mA typical program/erase current
 - ✓ 1 µA typical standby current (standard access time to active mode)
- Flexible sector architecture
 - ✓ Eight uniform 64 Kbyte each
 - ✓ Any combination of sectors can be erased
 - ✓ Supports full chip erase
- Sector protection
- Embedded Algorithms Erase & Program Algorithms
- Erase Suspend/Resume
- Minimum 1,000,000 Program/Erase Cycles per sector guaranteed
- Compatible with JEDEC standards
 - ✓ Pinout and software compatible with single-power-supply FLASH
- Data\ Polling and Toggle Bits
- 20-year data retention at 125°C

PIN ASSIGNMENT

(Top View)

32-PIN Ceramic DIP (CW)

32-pin Flatpack (F)

32-pin Lead Formed Flatpack (DCG)

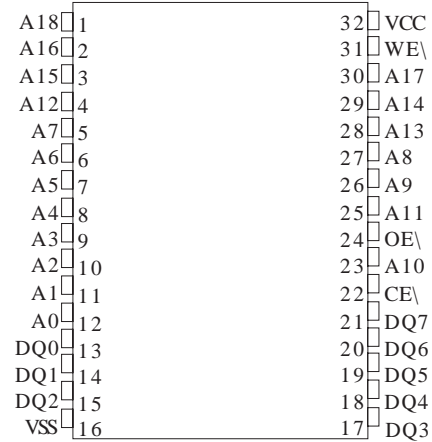

32-PAD Ceramic LCC (ECA)

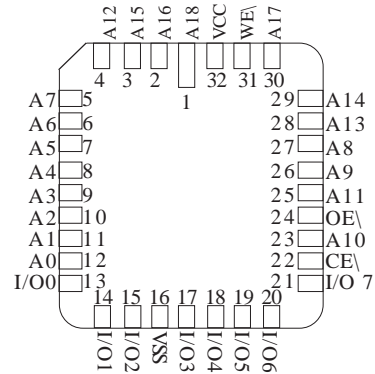

OPTIONS

- Timing
 - 55ns
 - 60ns
 - 70ns
 - 90ns
 - 120ns
 - 150ns

MARKING

- 55
- 60
- 70
- 90
- 120
- 150

For more products and information
please visit our web site at
www.austinsemiconductor.com

OPTIONS

• Package Type

- Ceramic DIP (600 mil)
- Flatpack
- Lead Formed Flatpack
- Leadless Chip Carrier

MARKING

- CW
- F
- DCG
- ECA

• Temperature Ranges

- Industrial Temperature (-40°C to +85°C) IT
- Military Temperature (-55°C to +125°C) XT**
- 883C Processing (-55°C to +125°C) 883C
- QML Processing (-55°C to +125°C) Q

GENERAL DESCRIPTION

The AS29F040 is a 4Mbit, 5.0 Volt-only FLASH memory organized as 524,288 Kbytes of 8 bits each. The 512 Kbytes of data are divided into eight sectors of 64 Kbytes each for flexible erase capability. The 8 bits of data appear on DQ0-DQ7. The device is designed to be programmed in-system with the standard system 5.0 Volt V_{CC} supply. A 12.0 volt V_{PP} is not required for write or erase operations. The device can also be programmed in standard EPROM programmers.

This device is manufactured using 0.32 μ m process technology. In addition, it has a second toggle bit, DQ2, and offers the ability to program in the Erase Suspend mode.

It is available with access times of 55, 60, 70, 90, 120, and 150ns, allowing high-speed microprocessors to operate without wait states. To eliminate bus contention the device has separate chip enable (CE\), write enable (WE\), and output enable (OE\) controls.

The device requires only a single 5.0 volt power supply for both read and write functions. Internally generated and regulated voltages are provided for the program and erase operations.

The device is entirely command set compatible with the JEDEC single-power-supply FLASH standard. Commands are written to the command register using standard microprocessor write timings. Register contents serve as input to an internal state-machine that controls the erase and programming circuitry. Write cycles also internally latch addresses and data needed for the programming and erase operations. Reading data out of the device is similar to reading from other FLASH or EPROM devices.

Device programming occurs by executing the program command sequence. This invokes the Embedded Program algorithm -- an internal algorithm that automatically times the

program pulse widths and verifies proper cell margin.

Device erasure occurs by executing the erase command sequence. This invokes the Embedded Erase algorithm -- an internal algorithm that automatically preprograms the array (if it is not already programmed) before executing the erase operation. During erase, the device automatically times the erase pulse widths and verifies proper cell margin.

The host system can detect whether a program or erase operation is complete by reading the DQ7 (Data\Polling) and DQ6 (toggle) status bits. After a program or erase cycle has been completed, the device is ready to read array data or accept another command.

The sector erase architecture allows memory sectors to be erased and reprogrammed without affecting the data contents of other sectors. The device is fully erased when shipped from the factory.

The hardware data protection measures include a low V_{CC} detector that automatically inhibits write operations during power transitions. The hardware sector protection feature disables both program and erase operations in any combination of the sectors of memory. This can be achieved via programming equipment.

The erase suspect feature enables the user to put erase on hold for any period of time to read data from, or program data to, any sector that is not selected for erasure. True background erase can thus be achieved.

The system can place the device into the standby mode. Power consumption is greatly reduced in this mode. The device electrically erases all bits within a sector simultaneously via Fowler-Nordheim tunneling. The data is programmed using hot electron injection.

PIN CONFIGURATION

PIN	DESCRIPTION
A0 - A18	Address Inputs
DQ0 - DQ7	Data Inputs/Outputs
CE\	Chip Enable
OE\	Output Enable
WE\	Write Enable
V_{CC}	+5V Single Power Supply
V_{SS}	Device Ground

LOGIC SYMBOL

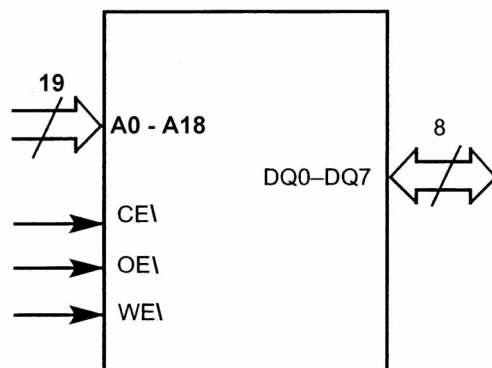

FUNCTIONAL BLOCK DIAGRAM

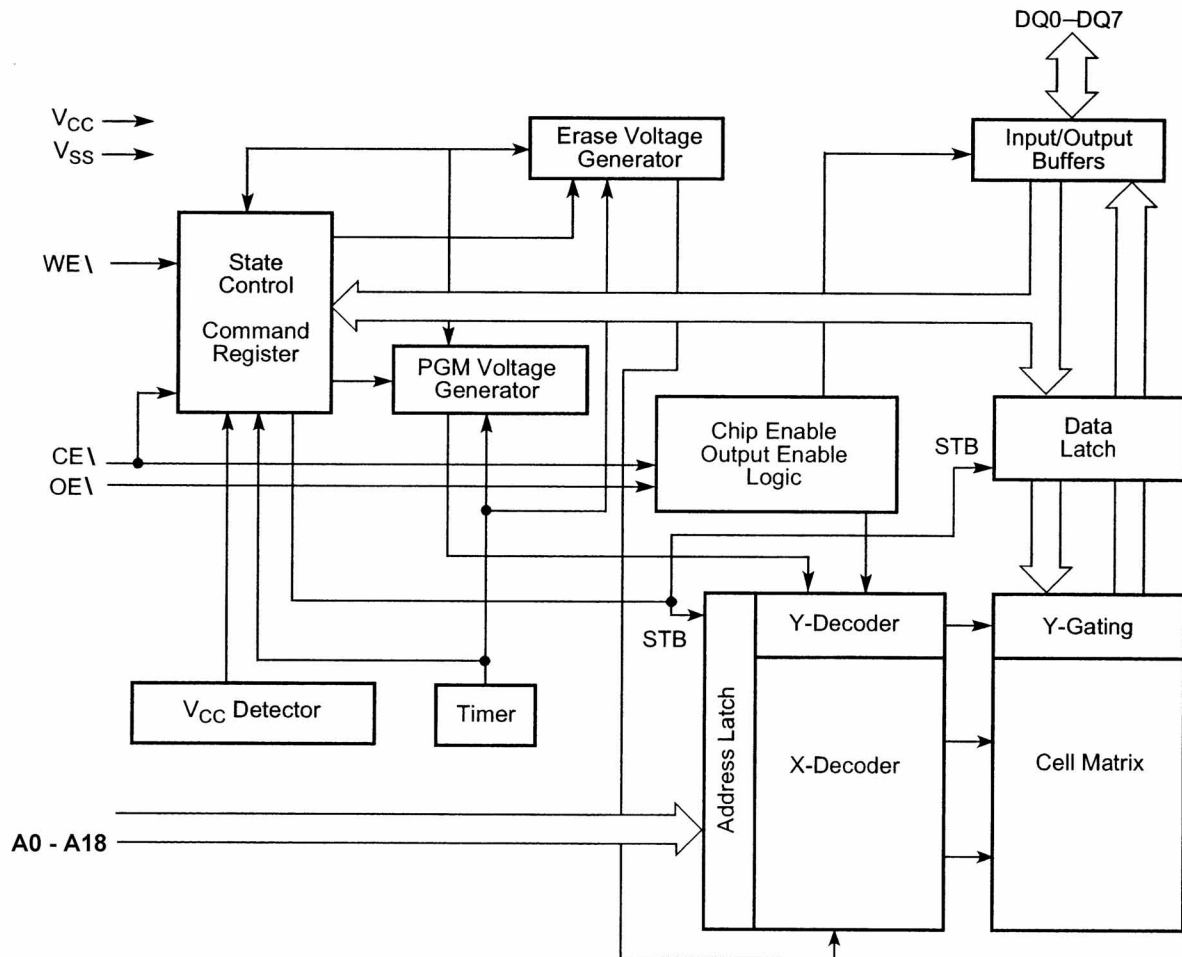

DEVICE BUS OPERATIONS

This section describes the requirements and use of the device bus operations, which are initiated through the internal command register. The command register itself does not occupy any addressable memory location. The register is composed of latches that store the commands, along with the address and data information needed to execute the command. The contents of the register serve as inputs to the internal state machine. The state machine outputs dictate the function of the device. The appropriate device bus operations table lists the inputs and control levels required, and the resulting output. The following subsections describe each of these operations in further detail.

Requirements for Reading Array Data

To read array data from the outputs, the system must drive the CE\ and OE\ pins to V_{IL} . CE\ is the power control and selects the device. OE\ is the output control and gates array data to the output pins. WE\ should remain at V_{IH} .

The internal state machine is set for reading array data upon device power-up, or after a hardware reset. This ensures that no spurious alteration of the memory content occurs during the power transition. No command is necessary in this mode to obtain array data. Standard microprocessor read cycles that assert valid addresses on the device address inputs produce valid data on the device data outputs. The device remains enabled for read access until the command register contents are altered.

See “Reading Array Data” for more information. Refer to the AC Read Operations table for timing specifications and to the Read Operations Timings diagram for the timing waveforms. I_{CC1} in the DC Characteristics table represents the active current specification for reading array data.

Writing Commands/Command Sequences

To write a command or command sequence (which includes programming data to the device and erasing sectors of memory), the system must drive WE\ and CE\ to V_{IL} , and OE\ to V_{IH} .

An erase operation can erase one sector, multiple sectors, or the entire device. The Sector Address Tables indicate the address space that each sector occupies. A “sector address” consists of the address bits required to uniquely select a sector. See the “Command Definitions” section for details on erasing a sector or the entire chip, or suspending/resuming the erase operation.

After the system writes the autoselect command sequence, the device enters the autoselect mode. The system can then read autoselect codes from the internal register (which is separate from the memory array) on DQ7 - DQ0. Standard read cycle timings apply in this mode. Refer to the “Autoselect Mode” and “Autoselect Command Sequence” sections for more information.

I_{CC2} in the DC Characteristics table represents the active current specification for the write mode. The “AC Characteristics” section contains timing specification tables and timing diagrams for write operations.

Program and Erase Operation Status

During an erase or program operation, the system may check the status of the operation by reading the status bits on DQ7 - DQ0. Standard read cycle timings and I_{CC} read specifications apply. Refer to “Write Operation Status” for more information, and to each AC Characteristics section for timing diagrams.

TABLE 1: DEVICE BUS OPERATIONS

OPERATION	CE\	OE\	WE\	A0 - A20	DQ0 - DQ7
Read	L	L	H	A_{IN}	D_{OUT}
Write	L	H	L	A_{IN}	D_{IN}
CMOS Standby	$V_{CC} \pm 0.5V$	X	X	X	High-Z
TTL Standby	H	X	X	X	High-Z
Output Disable	L	H	H	X	High-Z

NOTES: See the “Sector Protection/Unprotection” section for more information.

Standby Mode

When the system is not reading or writing to the device, it can place the device in the standby mode. In this mode, current consumption is greatly reduced, and the outputs are placed in the high impedance state, independent of the OE\ input.

The device enters the CMOS standby mode when the CE\ pin is held at $V_{CC} \pm 0.5V$. (Note that this is a more restricted voltage range than V_{IH} .) The device enters the TTL standby mode when CE\ is held at V_{IH} . The device requires the standard access time (t_{CE}) before it is ready to read data.

If the device is deselected during erasure or programming, the device draws active current until the operation is completed.

I_{CC3} in the DC Characteristics table represents the standby current specification.

Output Disable Mode

When the OE\ input is at V_{IH} , output from the device is disabled. The output pins are placed in the high impedance state.

Autoselect Mode

The autoselect mode provides manufacturer and device identification, and sector protection verification, through identifier codes output on DQ7 - DQ0. This mode is primarily intended for programming equipment to automatically match a device to be programmed with its corresponding programming algorithm. However, the autoselect codes can also be accessed in-system through the command register.

When using programming equipment, the autoselect mode requires V_{ID} (11.5V to 12.5 V) on address pin A9. Address pins A6, A1, and A0 must be as shown in the Autoselect Codes (High Voltage Method) table. In addition, when verifying sector protection, the sector address must appear on the appropriate highest order address bits. Refer to the corresponding Sector Address Tables. The Command

Definitions table shows the remaining address bits that are don't care. When all necessary bits have been set as required, the programming equipment may then read the corresponding identifier code on DQ7 - DQ0

To access the autoselect codes in-system, the host system can issue the autoselect command via the command register, as shown in the Command Definitions table. This method does not require V_{ID} . See "Command Definitions" for details on using the autoselect mode.

Sector Protection/Unprotection

The hardware sector protection feature disables both program and erase operations in any sector. The hardware sector unprotection feature re-enables both program and erase operations in previously protected sectors.

Sector protection/unprotection must be implemented using programming equipment. The procedure requires a high voltage (V_{ID}) on address pin A9 and the control pins. The device is shipped with all sectors unprotected. It is possible to determine whether a sector is protected or unprotected. See "Autoselect Mode" for details.

Hardware Data Protection

The command sequence requirement of unlock cycles for programming or erasing provides data protection against inadvertent writes (refer to the Command Definitions table). In addition, the following hardware data protection measures prevent accidental erasure or programming, which might otherwise be caused by spurious system level signals during V_{CC} power-up and power-down transitions, or from system noise.

Low V_{CC} Write Inhibit

When V_{CC} is less than V_{LKO} , the device does not accept any write cycles. This protects data during V_{CC} power-up and

TABLE 2: SECTOR ADDRESSES TABLE

SECTOR	A18	A17	A16	ADDRESS RANGE
SA0	0	0	0	00000h - 0FFFFh
SA1	0	0	1	10000h - 1FFFFh
SA2	0	1	0	20000h - 2FFFFh
SA3	0	1	1	30000h - 3FFFFh
SA4	1	0	0	40000h - 4FFFFh
SA5	1	0	1	50000h - 5FFFFh
SA6	1	1	0	60000h - 6FFFFh
SA7	1	1	1	70000h - 7FFFFh

NOTE: All sectors are 64 Kbytes in size.

power-down. The command register and all internal program/erase circuits are disabled, and the device resets. Subsequent writes are ignored until V_{CC} is greater than V_{LKO} . The system must provide the proper signals to the control pins to prevent unintentional writes when V_{CC} is greater than V_{LKO} .

Write Pulse “Glitch” Protection

Noise pulses of less than 5ns (typical) on OE\, CE\, or WE\ do not initiate a write cycle.

Logical Inhibit

Write cycles are inhibited by holding any one of OE\ = V_{IL} , CE\ = V_{IH} or WE\ = V_{IH} . To initiate a write cycle, CE\ and WE\ must be a logical zero while OE\ is a logical one.

Power-Up Write Inhibit

If WE\ = CE\ = V_{IL} and OE\ = V_{IH} during power up, the device does not accept commands on the rising edge of WE\. The internal state machine is automatically reset to reading array data on power-up.

COMMAND DEFINITIONS

Writing specific address and data commands or sequences into the command register initiates device operations. The Command Definitions table defines the valid register command sequences. Writing *incorrect address and data values* or writing them in the *improper sequence* resets the device to reading array data.

All addresses are latched on the falling edge of WE\ or CE\, whichever happens later. All data is latched on the rising edge of WE\ or CE\, whichever happens first. Refer to the appropriate timing diagrams in the “AC Characteristics” section.

Reading Array Data

The device is automatically set to reading array data after device power-up. No commands are required to retrieve data.

The device is also ready to read array data after completing an Embedded Program or Embedded Erase algorithm.

After the device accepts an Erase Suspend command, the device enters the Erase Suspend mode. The system can read array data using the standard read timings, except that if it reads at an address within erase-suspended sectors, the device outputs status data. After completing a programming operation in the Erase Suspend mode, the system may once again read array data with the same exception. See “Erase Suspend/Erase Resume” for more information.

The system *must* issue the reset command to re-enable the device for reading array data if DQ5 goes high, or while in the autoselect mode. See the “Reset Command” section, next.

See also “Requirements for Reading Array Data” in the “Device Bus Operations” section for more information. The Read Operations table provides the read parameters, and the Read Operation Timings diagram shows the timing diagram.

Reset Command

Writing the reset command to the device resets the device to reading array data. Address bits are don’t care for this command.

The reset command may be written between the sequence cycles in an erase command sequence before erasing begins. This resets the device to reading array data. Once erasure begins, however, the device ignores reset commands until the operation is complete.

The reset command may be written between the sequence cycles in a program command sequence before programming begins. This resets the device to reading array data (also applies to programming in Erase Suspend Mode). Once programming begins, however, the device ignores reset commands until the operation is complete.

The reset command may be written between the sequence cycles in an autoselect command sequence. Once in the autoselect mode, the reset command *must* be written to return to reading array data (also applies to autoselect during Erase Suspend).

TABLE 3: Autoselect Codes (High Voltage Method)

Description	A18 - A16	A15 - A10	A9	A8 - A7	A6	A5 - A2	A1	A0	Identifier Code On DQ7 to DQ0
Manufacturer ID	X	X	V_{ID}	X	V_{IL}	X	V_{IL}	V_{IL}	01h
Device ID	X	X	V_{ID}	X	V_{IL}	X	V_{IL}	V_{IH}	A4h
Sector Protection Verification	Sector Address	X	V_{ID}	X	V_{IL}	X	V_{IH}	V_{IL}	01h (protected)
									00h (unprotected)

If DQ5 goes high during a program or erase operation, writing the reset command returns the device to reading array data (also applies during Erase Suspend).

Autoselect Command Sequence

The autoselect command sequence allows the host system to access the manufacturer and device codes, and determine whether or not a sector is protected. The Command Definitions table shows the address and data requirements. This method is an alternative to that shown in the Autoselect Codes (High Voltage Method) table, which is intended for PROM programmers and requires V_{ID} on address bit A9.

The auto select command sequence is initiated by writing two unlock cycles, followed by the autoselect command. The device then enters the autoselect mode, and the system may read at any address any number of times, without initiating another command sequence.

A read cycle at address XX00h retrieves the manufacturer code. A read cycle at address XX01h returns the device code. A read cycle containing a sector address (SA) and the address 02h in returns 01h if that sector is protected, or 00h if it is unprotected. Refer to the Sector Address tables for valid sector addresses.

The system must write the reset command to exit the autoselect mode and return to reading array data.

Byte Program Command Sequence

Programming is a four-bus-cycle operation. The program command sequence is initiated by writing two unlock write cycles, followed by the program set-up command. The program address and data are written next, which in turn initiate the Embedded Program algorithm. The system is *not* required to provide further controls or timings. The device automatically provides internally generated program pulses and verify the programmed cell margin. The Command Definitions table shows the address and data requirements for the byte program command sequence.

When the Embedded Program algorithm is complete, the device then returns to reading array data and addresses are no longer latched. The system can determine the status of the program operation by using DQ7 or DQ6. See “Write Operation Status” for information on these status bits.

Any commands written to the device during the Embedded Program Algorithm are ignored.

Programming is allowed in any sequence and across sector boundaries. *A bit cannot be programmed from a “0” back to a “1”.* Attempting to do so may halt the operation and set DQ5 to “1”, or cause the Data Polling algorithm to indicate the operation was successful. However, a succeeding read will show that the data is still “0”. Only erase operations can convert a “0” to a “1”.

Chip Erase Command Sequence

Chip erase is a six-bus-cycle operation. The chip erase command sequence is initiated by writing two unlock cycles, followed by a set-up command. Two additional unlock write cycles are then followed by the chip erase command, which in turn invokes the Embedded Erase algorithm. The device does *not* require the system to preprogram prior to erase. The Embedded Erase algorithm automatically preprograms and verifies the entire memory for an all zero data pattern prior to electrical erase. The system is not required to provide any controls or timings during these operations. The Command Definitions table shows the address and data requirements for the chip erase command sequence.

Any commands written to the chip during the Embedded Erase algorithm are ignored.

The system can determine the status of the erase operation by using DQ7, DQ6, or DQ2. See “Write Operation Status” for information on these status bits. When the Embedded Erase algorithm is complete, the device returns to reading array data and addresses are no longer latched.

Figure 2 illustrates the algorithm for the erase operation. See the Erase/Program Operations tables in “AC Characteristics” for parameters, and the Chip /Sector Erase Operation Timings for timing waveforms.

FIGURE 1: PROGRAM OPERATION

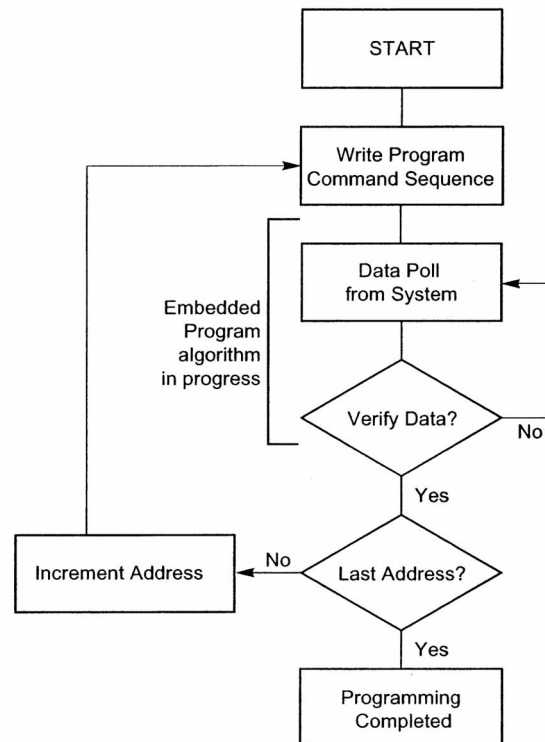

NOTE: See the appropriate Command Definitions table for program command sequence.

Sector Erase Command Sequence

Sector erase is a six bus cycle operation. The sector erase command sequence is initiated by writing two unlock cycles, followed by a set-up command. Two additional unlock write cycles are then followed by the address of the sector to be erased, and the sector erase command. The Command Definitions table shows the address and data requirements for the sector erase command sequence.

The device does *not* require the system to preprogram the memory prior to erase. The Embedded Erase algorithm automatically programs and verifies the sector for an all zero data pattern prior to electrical erase. The system is not required to provide any controls or timings during these operations.

After the command sequence is written, a sector erase time-out of 50µs begins. During the time-out period, additional sector addresses and sector erase commands may be written. Loading the sector erase buffer may be done in any sequence, and the number of sectors may be from one sector to all sectors. The time between these additional cycles must be less than 50µs, otherwise the last address and command might not be accepted, and erasure may begin. It is recommended that processor interrupts be disabled during this time to ensure all commands are accepted. The interrupts can be re-enabled after the last Sector Erase command is written. If the time between additional sector erase commands can be assumed to be less than 50µs, the system need not monitor DQ3. *Any command other than Sector Erase or Erase Suspend during the time-out period resets the device to reading array data.* The system must rewrite the command sequence and any additional sector addresses and commands.

The system can monitor DQ3 to determine if the sector erase timer has timed out. (See the “DQ3: Sector Erase Timer” section.) The time-out begins from the rising edge of the final WE pulse in the command sequence.

Once the sector erase operation has begun, only the Erase Suspend command is valid. All other commands are ignored.

When the Embedded Erase algorithm is complete, the device returns to reading array data and addresses are no longer latched. The system can determine the status of the erase operation by using DQ7, DQ6, or DQ2. Refer to “Write Operation Status” for information on these status bits.

Figure 2 illustrates the algorithm for the erase operation. Refer to the Erase/Program Operations tables in the “AC Characteristics” section for parameters, and to the Sector Erase Operations Timing diagram for timing waveforms.

Erase Suspend/Erase Resume Commands

The Erase Suspect command allows the system to interrupt a sector erase operation and then read data from, or program data to, any sector not selected for erasure. This command is valid only during the sector erase operation,

including the 50µs time-out period during the sector erase command sequence. The Erase Suspend command is ignored if written during the chip erase operation or Embedded Program algorithm. Writing the Erase Suspect command during the Sector Erase time-out immediately terminates the time-out period and suspends the erase operation. Addresses are “don’t cares” when writing the Erase Suspect command.

When the Erase Suspect command is written during a sector erase operation, the device requires a maximum of 20µs to suspend the erase operation. However, when the Erase Suspend command is written during the sector erase time-out, the device immediately terminates the time-out period and suspends the erase operation.

After the erase operation has been suspected, the system can read array data from any sector not selected for erasure. (The device “erase suspends” all sectors selected for erasure.) Normal read and write timings and command definitions apply. Reading at any address within erase-suspended sectors produces status data on DQ7-DQ0. The system can use DQ7, or DQ6 and DQ2 together, to determine if a sector is actively erasing or is erase-suspended. See “Write Operation Status” for information on these status bits.

FIGURE 2: ERASE OPERATION

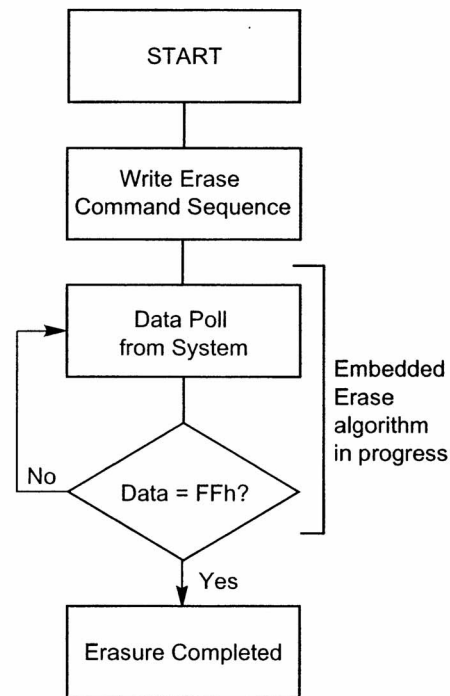

NOTE:

- 1) See the appropriate Command Definitions table for program command sequence.
- 2) See “DQ3: Sector Erase Timer” for more information.

After an erase-suspended program operation is complete, the system can once again read array data within non-suspended sectors. The system can determine the status of the program operation using the DQ7 or DQ6 status bits, just as in the standard program operation. See “Write Operation Status” for more information.

The system may also write the autoselect command sequence when the device is in the Erase Suspend mode. The device allows reading autoselect codes even at addresses within erasing sectors, since the codes are not stored in the memory

array. When the device exits the autoselect mode, the device reverts to the Erase Suspend mode, and is ready for another valid operation. See “Autoselect Command Sequence” for more information.

The system must write the Erase Resume command (address bits are “don’t care”) to exit the erase suspend mode and continue the sector erase operation. Further writes of the Resume command are ignored. Another Erase Suspend command can be written after the device has resumed erasing.

TABLE 4: Command Definitions

Command Sequence ¹	Cycles	Bus Cycles ^{2,3,4}												
		First		Second		Third		Fourth		Fifth		Sixth		
		Addr	Data	Addr	Data	Addr	Data	Addr	Data	Addr	Data	Addr	Data	
Read ⁵	1	RA	RD											
Reset ⁶	1	XXX	F0											
Autoselect ⁷	Manufacturer ID	4	555	AA	2AA	55	555	90	X00	01				
	Device ID	4	555	AA	2AA	55	555	90	X01	A4				
	Sector Protect Verify ⁸	4	555	AA	2AA	55	555	90	SA X02	00 01				
Program	4	555	AA	2AA	55	555	A0	PA	PD					
Chip Erase	6	555	AA	2AA	55	555	80	555	AA	2AA	55	555	10	
Sector Erase	6	555	AA	2AA	55	555	80	555	AA	2AA	55	SA	30	
Erase Suspend ⁹	1	XXX	B0											
Erase Resume ¹⁰	1	XXX	30											

LEGEND:

- X = Don't Care.
- RA = Address of the memory location to be read.
- RD = Data read from location RA during read operation.
- PA = Address of the memory location to be programmed. Addresses latch on the falling edge of the WE\ or CE\ pulse, whichever happens later.
- PD = Data to be programmed at location PA. Data latches on the rising edge of WE\ or CE\ pulse, whichever happens first.
- SA = Address of the sector to be verified (in autoselect mode) or erased. Address bits A18-A16 uniquely select any sector.

NOTES:

1. See Table 1 for description of bus operations.
2. All values are in hexadecimal.
3. Except when reading array or autoselect data, all command bus cycles are write operations.
4. Address bits A18 - A11 are don't care for unlock and command cycles, unless SA or PA required.
5. No unlock or command cycles required when reading array data.
6. The Reset command is required to return to reading array data when device is in the autoselect mode, or if DQ5 goes high (while the device is providing status data).
7. The fourth cycle of the autoselect command sequence is a read cycle.
8. The data is 00h for an unprotected sector and 01h for a protected sector. See “Autoselect Command Sequence” for more information.
9. The system may read and program in non-erasing sectors, or enter the autoselect mode, when in the Erase Suspend mode. The Erase Suspend command is valid only during a sector erase operation.
10. The Erase Resume command is valid only during the Erase Suspend mode.

WRITE OPERATION STATUS

The device provides several bits to determine the status of a write operation: DQ2, DQ3, DQ5, DQ6, and DQ7. Table 5 and the following subsections describe the functions of these bits. DQ7 and DQ6 each offer a method for determining whether a program or erase operation is complete or in progress. These three bits are discussed first.

DQ7: Data\ Polling

The Data\ Polling bit, DQ7, indicates to the host system whether an Embedded Algorithm is in progress or completed, or whether the device is in Erase Suspend. Data\ Polling is valid after the rising edge of the final WE\ pulse in the program or erase command sequence.

During the Embedded Program algorithm, the device outputs on DQ7 the complement of the datum programmed to DQ7. This DQ7 status also applies to programming during Erase Suspend. When the Embedded Program algorithm is complete, the device outputs the datum programmed to DQ7. The system must provide the program address to read valid status information on DQ7. If a program address falls within a protected sector, Data\ Polling on DQ7 is active for approximately 2μs, then the device returns to reading array data.

During the Embedded Erase algorithm, Data\ Polling produces a “0” on DQ7. When the Embedded Erase algorithm is complete, or if the device enters the Erase Suspend mode, Data\ Polling produces a “1” on DQ7. This is analogous to the complement/true datum output described for the Embedded Program algorithm: the erase function changes all the bits in a sector to “1”; prior to this, the device outputs the “complement,” or “0”. The system must provide an address within any of the sectors selected for erasure to read valid status information on DQ7.

After an erase command sequence is written, if all sectors selected for erasing are protected, Data\ Polling on DQ7 is active for approximately 100μs, then the device returns to reading array data. If not all selected sectors are protected, the Embedded Erase algorithm erases the unprotected sectors, and ignores the selected sectors that are protected.

When the system detects DQ7 has changed from the complement to true data, it can read valid data at DQ7-DQ0 on the following read cycles. This is because DQ7 may change asynchronously with DQ0-DQ6 while Output Enable (OE\) is asserted low. The Data\ Polling Timings (During Embedded Algorithms) figure in the “AC Characteristics” section illustrates this.

Table 5 shows the outputs for Data\ Polling on DQ7. Figure 3 shows the Data\ Polling algorithm.

DQ6: Toggle Bit I

Toggle bit I on DQ6 indicates whether an Embedded Program or Erase algorithm is in progress or complete, or whether the device has entered the Erase Suspend mode. Toggle Bit I may be read at any address, and is valid after the rising edge of the final WE\ pulse in the command sequence (prior to the program or erase operation), and during the sector erase time-out.

During an Embedded Program or Erase algorithm operation, successive read cycles to any address cause DQ6 to

FIGURE 3: DATA\ POLLING ALGORITHM

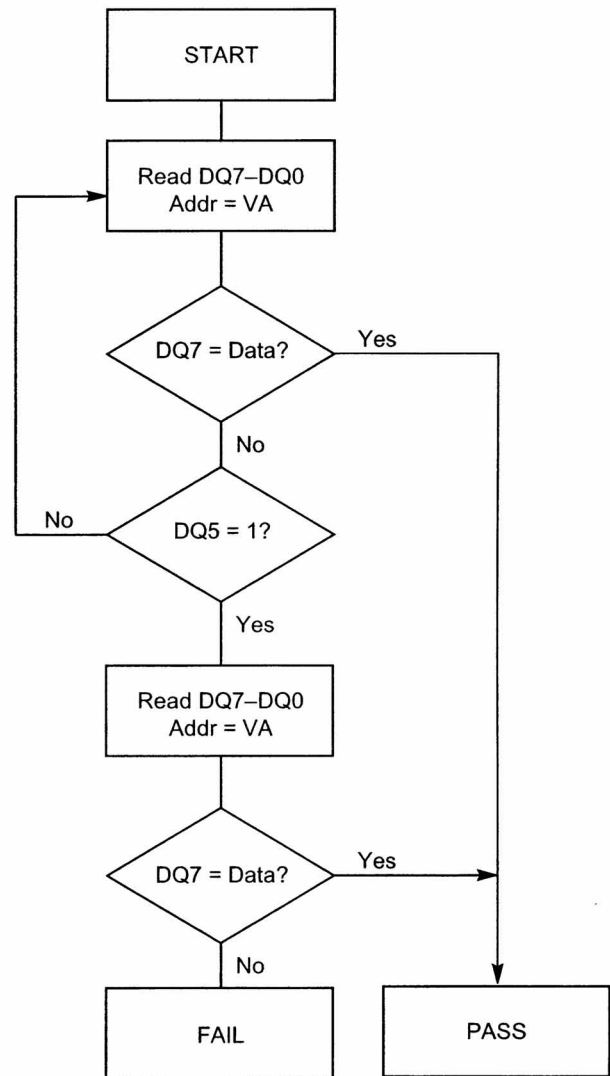

NOTE:

- 1) VA = Valid address for programming. During a sector erase operation, a valid address is an address within any sector selected for erasure. During chip erase, a valid address is any non-protected sector address.
- 2) DQ7 should be rechecked even if DQ5 = “1” because DQ7 may change simultaneously with DQ5.

toggle. (The system may use either OE\ or CE\ to control the read cycles.) When the operation is complete, DQ6 stops toggling.

After an erase command sequence is written, if all sectors selected for erasing are protected, DQ6 toggles for approximately 100µs, then returns to reading array data. If not all selected sectors are protected, the Embedded Erase algorithm erases the unprotected sectors, and ignores the selected sectors that are protected.

The system can use DQ6 and DQ2 together to determine whether a sector is actively erasing or is erase-suspended. When the device is actively erasing (that is, the Embedded Erase algorithm is in progress), DQ6 toggles. When the device enters the Erase Suspend mode, DQ6 stops toggling. However the system must also use DQ2 to determine which sectors are erasing or erase-suspended. Alternatively, the system can use DQ7 (see the subsection on “DQ7: Data\ Polling”).

If a program address falls within a protected sector, DQ6 toggles for approximately 2µs after the program command sequence is written, then returns to reading array data.

DQ6 also toggles during the erase-suspend-program mode, and stops toggling once the Embedded Program algorithm is complete.

The Write Operation Status table shows the outputs for Toggle Bit I on DQ6. Refer to Figure 4 for the toggle bit algorithm, and to the Toggle Bit Timings figure in the “AC Characteristics” section for the timing diagram. The DQ2 vs. DQ6 figure shows the differences between DQ2 and DQ6 in graphical form. See also the subsection on “DQ2: Toggle Bit II”.

DQ2: Toggle Bit II

The “Toggle Bit II” on DQ2, when used with DQ6, indicates whether a particular sector is actively erasing (that is, the Embedded Erase algorithm is in progress), or whether that sector is erase-suspended. Toggle Bit II is valid after the rising edge of the final WE\ pulse in the command sequence.

DQ2 toggles when the system reads at addresses within those sectors taht have been selected for erasure. (The system may use either OE\ or CE\ to control the read cycles.) But DQ2 cannot distinguish whether the sector is actively erasing or is erase-suspended. DQ6, by comparison, indicates whether the device is actively erasing, or is in Erase Suspend, but cannot distinguish which sectors are selected for erasure. Thus, both status bits are required for sector and mode information. Refer to Table 5 to compare outputs for DQ2 and DQ6.

Figure 4 shows the toggle bit algorithm in flowchart form, and the section “DQ2: Toggle Bit II” explains the algorithm. See also the “DQ6: Toggle Bit I” subsection. Refer to the Toggle Bit Timings figure for the toggle bit timing diagram. The DQ2 vs. DQ6 figure shows the differences between DQ2 and DQ6 in graphical form.

Reading Toggle Bit DQ6/DQ2

Refer to Figure 4 for the following discussion. Whenever the system initially begins reading toggle bit status, it must read DQ7-DQ0 at least twice in a row to determine whether a toggle bit is toggling. Typically, a system would note and store the value of the toggle bit after the first read. After the second read, the system would compare the new value of the toggle bit with the first. If the toggle bit is not toggling, the device has

FIGURE 4: TOGGLE BIT ALGORITHM

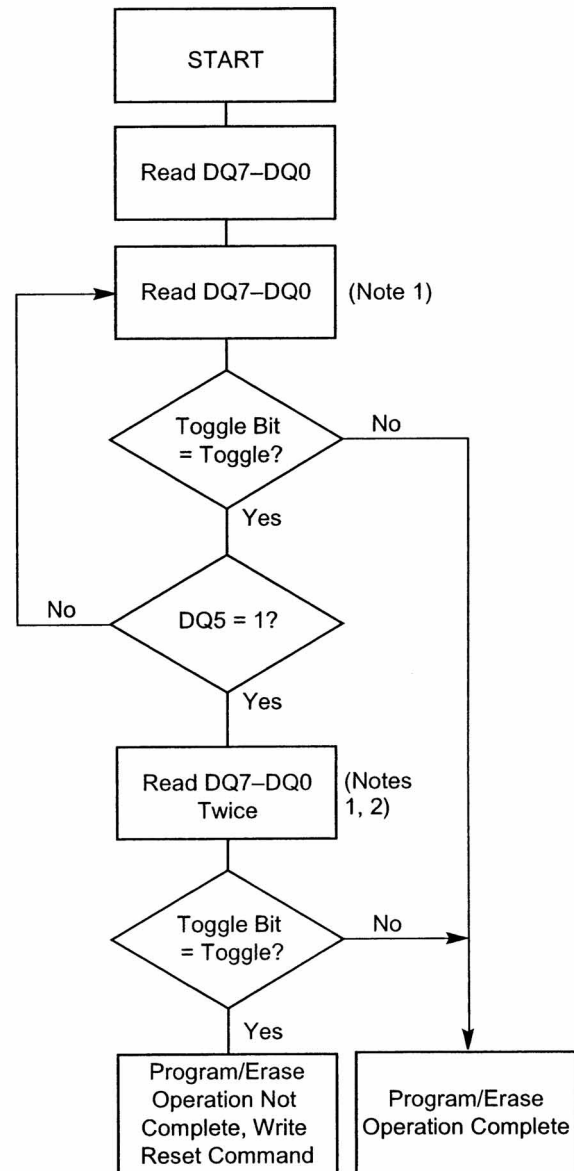

NOTE:

- 1) Read toggle bit twice to determine whether or not it is toggling. See text.
- 2) Recheck toggle bit because it may stop toggling as DQ5 changes to “1”. See text.

completed the program or erase operation. The system can read array data on DQ7-DQ0 on the following read cycle.

However, if after the initial two read cycles, the system determines that the toggle bit is still toggling, the system also should note whether the value of DQ5 is high (see the section on DQ5). If it is, the system should then determine again whether the toggle bit is toggling, since the toggle bit may have stopped toggling just as DQ5 went high. If the toggle bit is no longer toggling, the device has successfully completed the program or erase operation. If it is still toggling, the device did not complete the operation successfully, and the system must write the reset command to return to reading array data.

The remaining scenario is that the system initially determines that the toggle bit is toggling and DQ5 has not gone high. The system may continue to monitor the toggle bit and DQ5 through successive read cycles, determining the status as described in the previous paragraph. Alternatively, it may choose to perform other system tasks. In this case, the system must start at the beginning of the algorithm when it returns to determine the status of the operation (top of Figure 4).

DQ5: Exceeded Timing Limits

DQ5 indicates whether the program or erase time has exceeded a specified internal pulse count limit. Under these conditions DQ5 produces a “1.” This is a failure condition that indicates the program or erase cycle was not successfully completed.

The DQ5 failure condition may appear if the system tries to program a “1” to a location that is previously programmed to “0.” *Only an erase operation can change a “0” back to a “1.”*

Under this condition, the device halts the operation, and when the operation has exceeded the timing limits, DQ5 produces a “1.”

Under both these conditions, the system must issue the reset command to return the device to reading array data.

DQ3: Sector Erase Timer

After writing a sector erase command sequence, the system may read DQ3 to determine whether or not an erase operation has begun. (The sector erase timer does not apply to the chip erase command.) If additional sectors are selected for erasure, the entire time-out also applies after each additional sector erase command. When the time-out is complete, DQ3 switches from “0” to “1.” The system may ignore DQ3 if the system can guarantee that the time between additional sector erase commands will always be less than 50µs. See also the “Sector Erase Command Sequence” section.

After the sector erase command sequence is written, the system should read the status on DQ7 (Data\ Polling) or DQ6 (Toggle Bit I) to ensure the device has accepted the command sequence, and then read DQ3. If DQ3 is “1”, the internally controlled erase cycle has begun; all further commands (other than Erase Suspend) are ignored until the erase operation is complete. If DQ3 is “0”, the device will accept additional sector erase commands. To ensure the command has been accepted, the system software should check the status of DQ3 prior to and following each subsequent sector erase command. If DQ3 is high on the second status check, the last command might not have been accepted. Table 5 shows the outputs for DQ3.

TABLE 5: WRITE OPERATION STATUS

OPERATION		DQ7 ¹	DQ6	DQ5 ²	DQ3	DQ2 ¹
Standard Mode	Embedded Program Algorithm	DQ7\	Toggle	0	0	No Toggle
	Embedded Erase Algorithm	0	Toggle	0	1	Toggle
Erase Suspend Mode	Reading within Erase Suspended Sector	1	No toggle	0	N/A	Toggle
	Reading within Non-Erase Suspended Sector	Data	Data	Data	Data	Data
	Erase-Suspend-Program	DQ7\	Toggle	0	N/A	N/A

NOTES:

1. DQ7 and DQ2 requires a valid address when reading status information. Refer to the appropriate subsection for further details.
2. DQ5 switches to ‘1’ when an Embedded Program or Embedded Erase operation has exceeded the maximum timing limits. See “DQ5: Exceeding Timing Limits” for more information.

ABSOLUTE MAXIMUM RATINGS*

Ambient Temperature with Power Applied.....-55°C to +125°C
Voltage with Respect to Ground

V_{CC}^1-2.0V to +7.0V

A9, OE \setminus ².....-2.0V to +12.5V

All other pins¹.....-2.0V to +7.0V

V_{CC} Supply Voltage ($\pm 10\%$).....-4.5V to +5.5V

Output Short Circuit Current³.....200mA

Storage Temperature.....-65°C to +125°C

NOTES:

1. Minimum DC voltage on input or I/O pin is -0.5V. During voltage transitions, input may overshoot V_{SS} to -2.0V for periods of up to 20ns. See Figure 5. Maximum DC voltage on input and I/O pins is $V_{CC} + 0.5V$. During voltage transitions, input and I/O pins may overshoot $V_{CC} + 2.0V$ for periods up to 20ns. See Figure 6.

2. Minimum DC voltage on A9 pin is -0.5V. During voltage transitions, A9 and OE \setminus pins may overshoot V_{SS} to -2.0V for periods of up to 20ns. See Figure 5. Maximum DC input voltage on A9 and OE \setminus is +12.5V which may overshoot to 13.5V for periods up to 20ns.

3. No more than one output shorted to ground at a time. Duration of the short circuit should not be greater than one second.

*Stresses greater than those listed under "Absolute Maximum Ratings" may cause permanent damage to the device. This is a stress rating only and functional operation of the device at these or any other conditions above those indicated in the operation section of this specification is not implied. Exposure to absolute maximum rating conditions for extended periods may affect reliability.

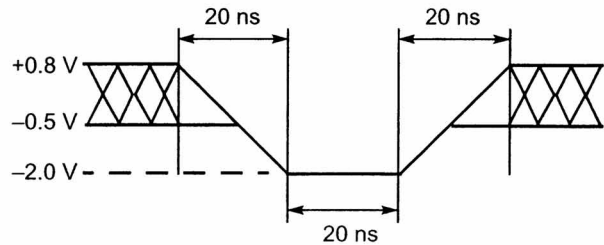

FIGURE 5: Maximum Negative Overshoot Waveform

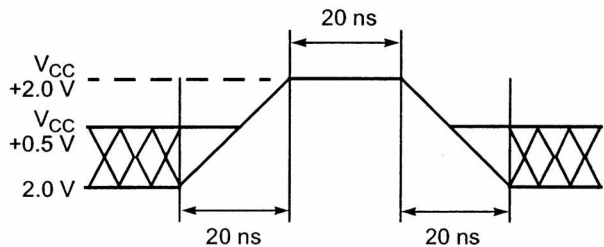

FIGURE 6: Maximum Positive Overshoot Waveform

DC CHARACTERISTICS: TTL/NMOS Compatible

PARAMETER	DESCRIPTION	SYM	MIN	TYP	MAX	UNIT
Input Load Current	$V_{IN} = V_{SS}$ to V_{CC} , $V_{CC} = V_{CC}$ Max	I_{LI}			±1.0	μA
A9 Input Load Current	$V_{CC} = V_{CC}$ Max, A9 = 12.5V	I_{LIT}			50	μA
Output Leakage Current	$V_{OUT} = V_{SS}$ to V_{CC} , $V_{CC} = V_{CC}$ Max	I_{LO}			±1.0	μA
V_{CC} Active Read Current ^{1,2}	$CE \setminus = V_{IL}$, $OE \setminus = V_{IH}$	I_{CC1}		20	30	mA
V_{CC} Active Write (Program/Erase) Current ^{2,3,4}	$CE \setminus = V_{IL}$, $OE \setminus = V_{IH}$	I_{CC2}		30	40	mA
V_{CC} Standby Current ²	$CE \setminus = V_{IH}$	I_{CC3}		0.4	1.0	mA
Input Low Voltage		V_{IL}	-0.5		0.8	V
Input High Voltage		V_{IH}	2.0		$V_{CC} + 0.5$	V
Voltage for Autoselect and Sector Protect	$V_{CC} = 5.25V$	V_{ID}	10.5		12.5	V
Output Low Voltage	$I_{OL} = 12$ mA, $V_{CC} = V_{CC}$ Min	V_{OL}			0.45	V
Output High Voltage	$I_{OH} = -2.5$ mA, $V_{CC} = V_{CC}$ Min	V_{OH}	2.4			V
Low V_{CC} Lock-out Voltage		V_{LKO}	3.2		4.2	V

DC CHARACTERISTICS: CMOS Compatible

PARAMETER	DESCRIPTION	SYM	MIN	TYP	MAX	UNIT
Input Load Current	$V_{IN} = V_{SS}$ to V_{CC} , $V_{CC} = V_{CC}$ Max	I_{LI}			±1.0	μA
A9 Input Load Current	$V_{CC} = V_{CC}$ Max, A9 = 12.5V	I_{LIT}			50	μA
Output Leakage Current	$V_{OUT} = V_{SS}$ to V_{CC} , $V_{CC} = V_{CC}$ Max	I_{LO}			±1.0	μA
V_{CC} Active Read Current ^{1,2}	$CE \setminus = V_{IL}$, $OE \setminus = V_{IH}$	I_{CC1}		20	30	mA
V_{CC} Active Program/Erase Current ^{2,3,4}	$CE \setminus = V_{IL}$, $OE \setminus = V_{IH}$	I_{CC2}		30	40	mA
V_{CC} Standby Current ^{2, 5}	$CE \setminus = V_{CC} \pm 0.5V$	I_{CC3}		1	5	μA
Input Low Voltage		V_{IL}	-0.5		0.8	V
Input High Voltage		V_{IH}	$0.7 \times V_{CC}$		$V_{CC} + 0.3$	V
Voltage for Autoselect and Sector Protect	$V_{CC} = 5.25V$	V_{ID}	10.5		12.5	V
Output Low Voltage	$I_{OL} = 12$ mA, $V_{CC} = V_{CC}$ Min	V_{OL}			0.45	V
Output High Voltage	$I_{OH} = -2.5$ mA, $V_{CC} = V_{CC}$ Min	V_{OH1}	$0.85 V_{CC}$			V
	$I_{OH} = -100$ μA, $V_{CC} = V_{CC}$ Min	V_{OH2}	$V_{CC} - 0.4$			V
Low V_{CC} Lock-out Voltage		V_{LKO}	3.2		4.2	V

NOTES:

1. The I_{CC} current listed includes both the DC operating current and the frequency dependent component (at 6 MHz). The frequency component typically is less than 2mA/MHz, with $OE \setminus$ at V_{IH} .
2. Maximum I_{CC} specifications are tested with $V_{CC} = V_{CC}$ Max.
3. I_{CC} active while Embedded Algorithm (program or erase) is in progress.
4. Not 100% tested.
5. For CMOS mode only, $I_{CC3} = 20\mu A$ max at extended temperatures (>+85°C).

FIGURE 7: TEST CONDITIONS, Test Setup

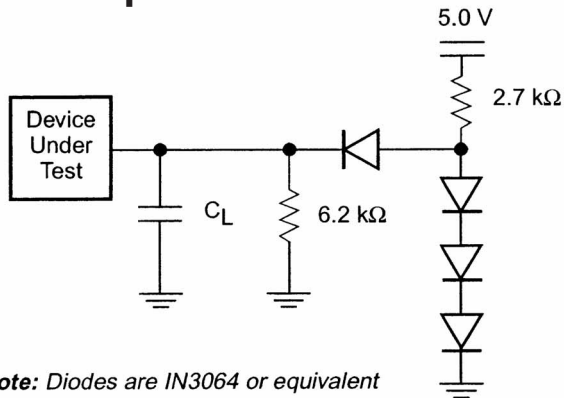

Note: Diodes are IN3064 or equivalent

TABLE 6: TEST CONDITIONS, Test Specifications

CONDITIONS	-55	ALL OTHERS	UNIT
Output Load	1 TTL Gate		
Output Load Capacitance, C_L (including jig capacitance)	30	100	pF
Input Rise and Fall Times	5	20	ns
Input Pulse Levels	0.0 - 3.0	0.45 - 2.4	V
Input timing measurement reference levels	1.5	0.8, 2.0	V
Output timing measurement reference levels	1.5	0.8, 2.0	V

AC CHARACTERISTICS: Read-Only Operations

PARAMETER	SYMBOL		TEST SETUP	SPEED OPTIONS ¹					UNITS	
	JEDEC	Std		-55	-70	90	-120	-150		
Read Cycle Time ³	t_{AVAV}	t_{RC}	MIN	55	70	90	120	150	ns	
Address to Output Delay	t_{AVQV}	t_{ACC}	$CE \setminus = V_{IL}$ $OE \setminus = V_{IL}$ MAX	55	70	90	120	150	ns	
Chip Enable to Output Delay	t_{ELQV}	t_{CE}	$OE \setminus = V_{IL}$ MAX	55	70	90	120	150	ns	
Output Enable to Output Delay	t_{GLQV}	t_{OE}	MAX	30	30	35	50	55	ns	
Chip Enable to Output High Z ^{2, 3}	t_{EHQZ}	t_{DF}	MAX	18	20	20	30	35	ns	
Output Enable to Output High Z ^{2, 3}	t_{GHQZ}	t_{DF}		18	20	20	30	35	ns	
Output Enable Hold Time ³		t_{OEH}	Read	MIN	0	0	0	0	0	ns
			Toggle and Data Polling	MIN	10	10	10	10	10	ns
Output Hold Time From Addresses CE\ or OE\, Whichever Occurs First	t_{AXQX}	t_{OH}	MIN	0	0	0	0	0	ns	

NOTES:

1. See Figure 7 and Table 6 for test specifications.
2. Output driver disable time.
3. Not 100% tested.

FIGURE 8: AC CHARACTERISTICS, Read Operations Timings

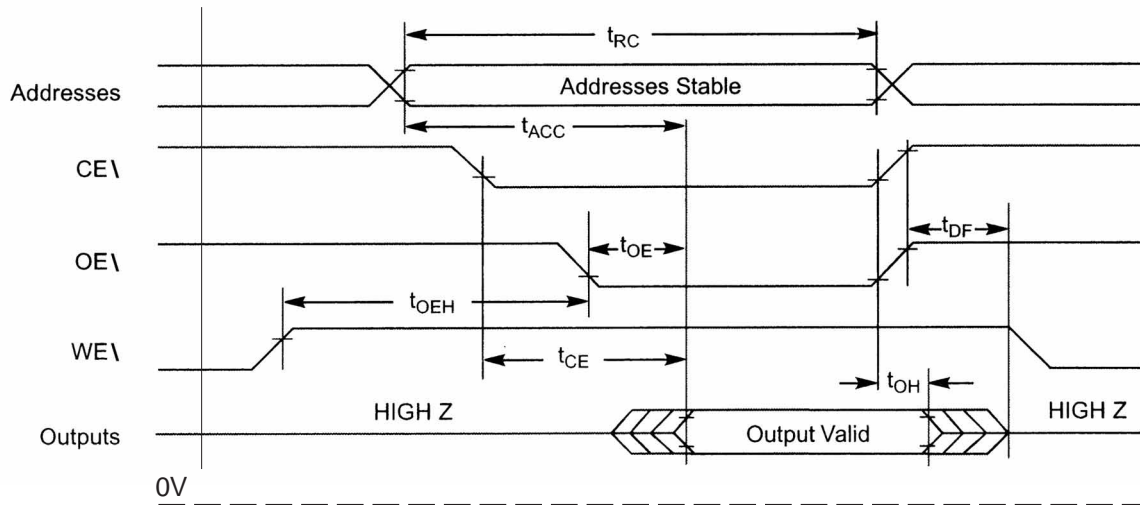

AC CHARACTERISTICS: Erase and Program Operations

PARAMETER		SYMBOL		SPEED OPTIONS					UNITS
		JEDEC	Std	-55	-70	90	-120	-150	
Write Cycle Time ¹	MIN	t_{AVAV}	t_{WC}	55	70	90	120	150	ns
Address Setup Time	MIN	t_{AVWL}	t_{AS}	0					ns
Address Hold Time	MIN	t_{WLAX}	t_{AH}	40	45	45	50	50	ns
Data Setup Time	MIN	t_{DVWH}	t_{DS}	25	30	45	50	50	ns
Data Hold Time	MIN	t_{WHDX}	t_{DH}	0					ns
Output Enable Setup Time	MIN		t_{OES}	0					ns
Read Recover Time Before Write (OE\ High to WE\ Low)	MIN	t_{GHWL}	t_{GHWL}	0					ns
CE\ Setup Time	MIN	t_{ELWL}	t_{CS}	0					ns
CE\ Hold Time	MIN	t_{WHEH}	t_{CH}	0					ns
Write Pulse Width	MIN	t_{WLWH}	t_{WP}	30	35	45	50	50	ns
Write Pulse Width High	MIN	t_{WHWL}	t_{WPH}	20					ns
Byte Programming Operation ²	TYP	t_{WHWH1}	t_{WHWH1}	7					μ s
Sector Erase Operation ²	TYP	t_{WHWH2}	t_{WHWH2}	1					sec
V _{CC} Set Up Time ¹	MIN		t_{VCS}	50					μ s

NOTES:

- Not 100% tested.
- See the "Erase and Programming Performance" section for more information.

FIGURE 9: AC CHARACTERISTICS, Program Operation Timings

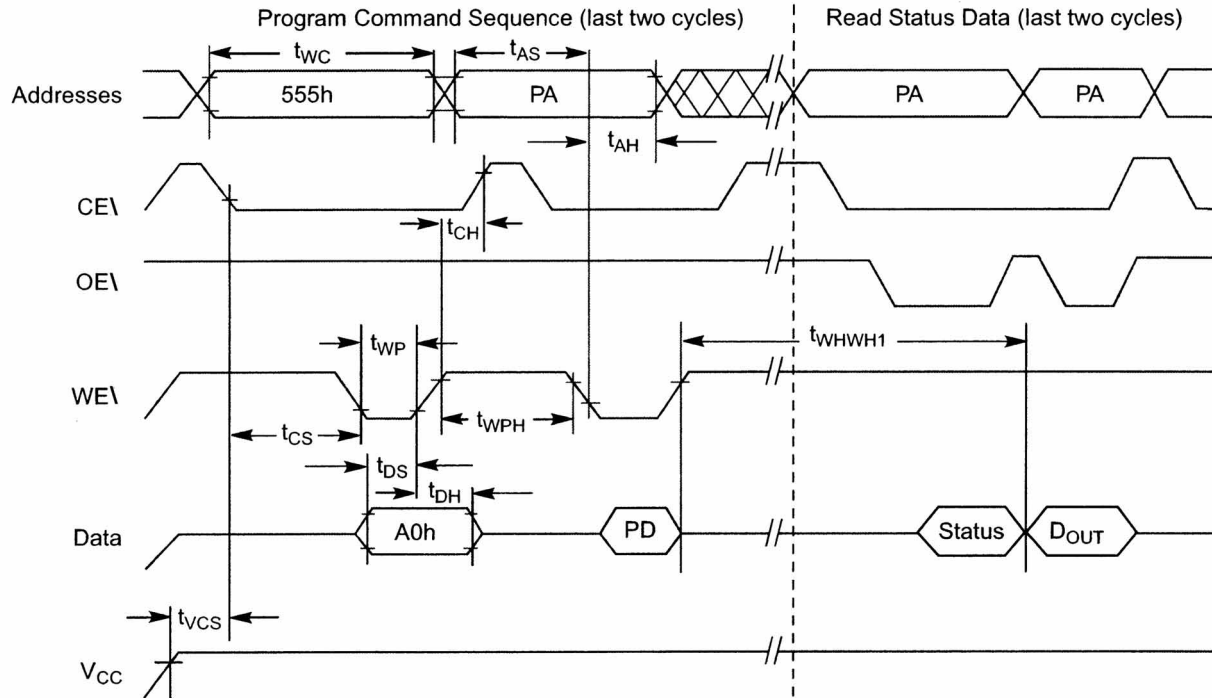

NOTES: PA = program address, PD = program data, D_{OUT} is the true data at the program address.

FIGURE 10: AC CHARACTERISTICS, Chip/Sector Erase Operation Timings

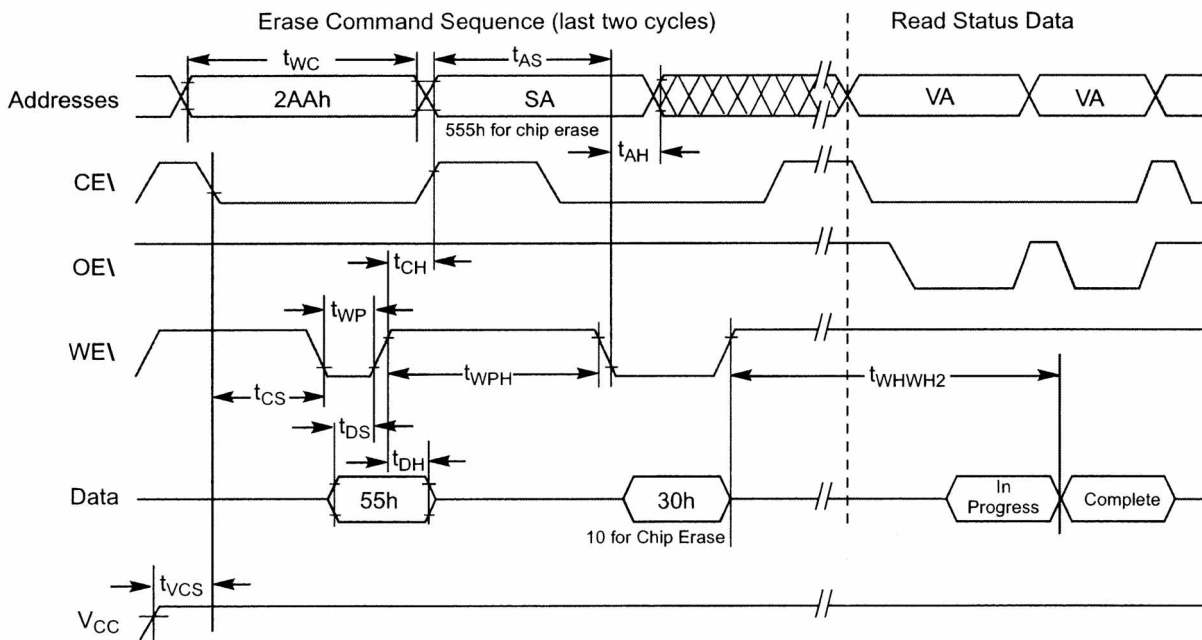

NOTES: SA = sector address (for Sector Erase), VA = Valid Address for reading status data.

FIGURE 11: Data\ Polling Timings (During Embedded Algorithms)

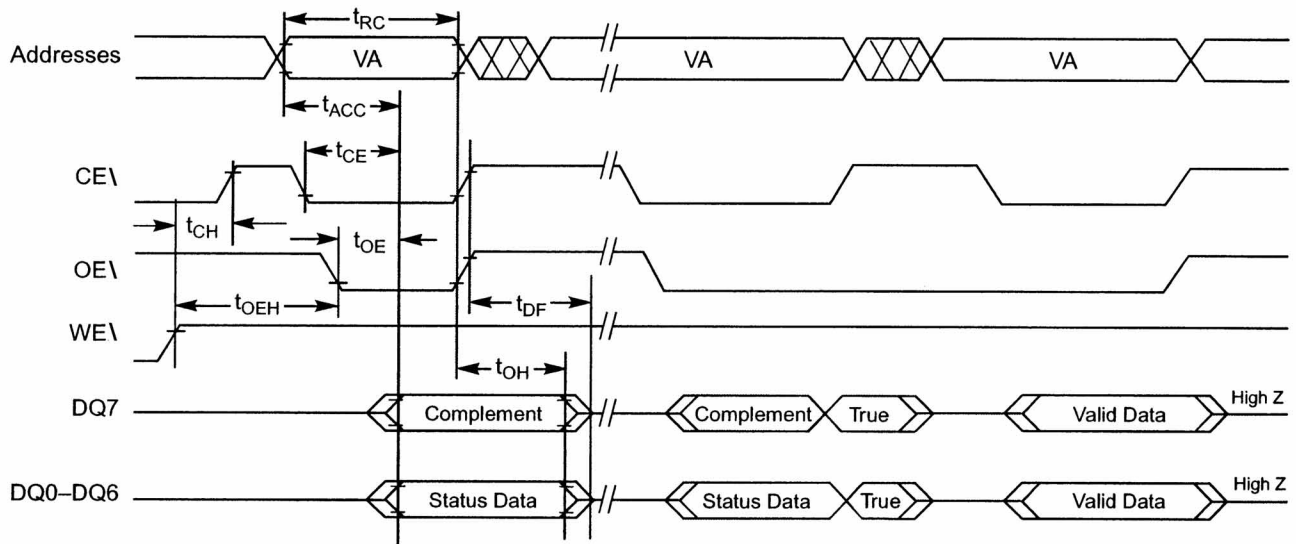

NOTES: VA = Valid address. Illustration shows first status cycle after command sequence, last status read cycle, and array data read cycle.

FIGURE 12: AC CHARACTERISTICS, Toggle Bit Timings (During Embedded Algorithms)

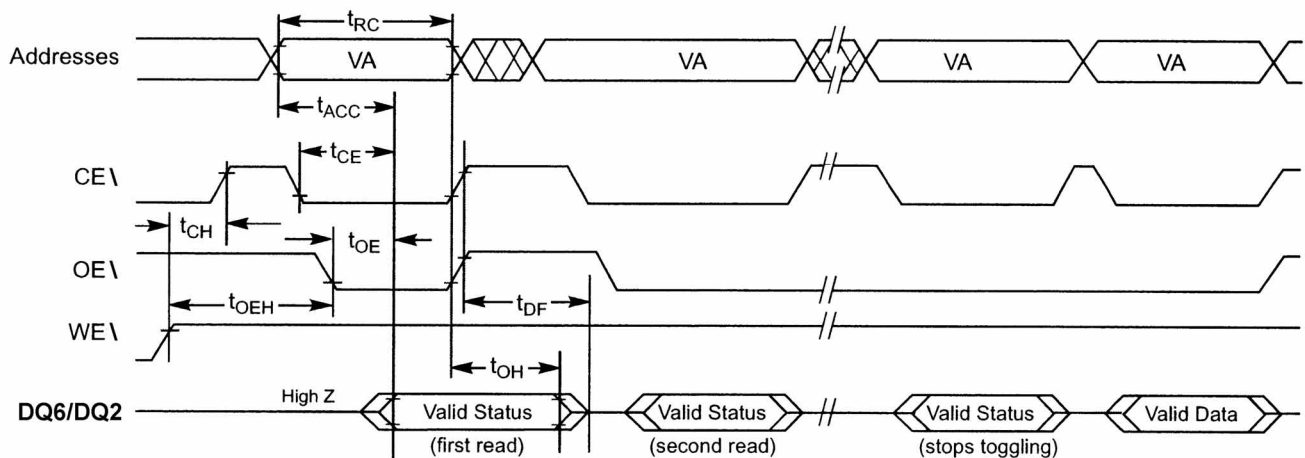

NOTES: VA = Valid address, not required for DQ6. Illustration shows first two status cycle after command sequence, last status read cycle, and array data read cycle.

FIGURE 13: AC CHARACTERISTICS, DQ2 vs. DQ6

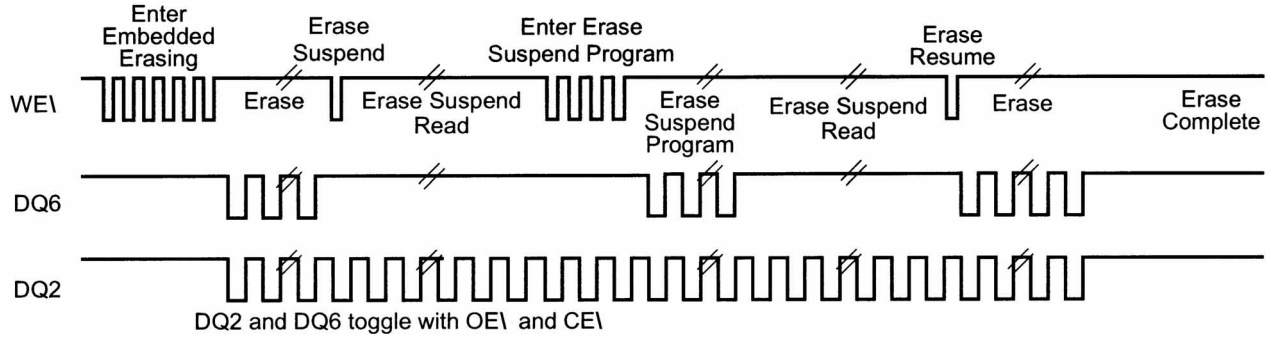

NOTES: Both DQ6 and DQ2 toggle with OE or CE. See the text on DQ6 and DQ2 in section “Write Operation Status” for more information.

AC CHARACTERISTICS: Erase and Program Operations (Alternate CE Controlled Writes)

PARAMETER		SYMBOL		SPEED OPTIONS					UNITS
		JEDEC	Std	-55	-70	90	-120	-150	
Write Cycle Time ¹	MIN	t _{AVAV}	t _{WC}	55	70	90	120	150	ns
Address Setup Time	MIN	t _{AVWL}	t _{AS}	0					ns
Address Hold Time	MIN	t _{WLAX}	t _{AH}	40	45	45	50	50	ns
Data Setup Time	MIN	t _{DVWH}	t _{DS}	25	30	45	50	50	ns
Data Hold Time	MIN	t _{WHDX}	t _{DH}	0					ns
Output Enable Setup Time	MIN		t _{OES}	0					ns
Read Recover Time Before Write (OE High to WE Low)	MIN	t _{GHWL}	t _{GHWL}	0					ns
CE Setup Time	MIN	t _{ELWL}	t _{CS}	0					ns
CE Hold Time	MIN	t _{WHEH}	t _{CH}	0					ns
Write Pulse Width	MIN	t _{WLWH}	t _{WP}	30	35	45	50	50	ns
Write Pulse Width High	MIN	t _{WHWL}	t _{WPH}	20					ns
Byte Programming Operation ²	TYP	t _{WHWH1}	t _{WHWH1}	7					μs
Sector Erase Operation ²	TYP	t _{WHWH2}	t _{WHWH2}	1					sec
V _{CC} Set Up Time ¹	MIN		t _{VCS}	50					μs

NOTES:

- Not 100% tested.
- See the “Erase and Programming Performance” section for more information.

FIGURE 14: AC CHARACTERISTICS, Alternate CE\ Controlled Write Operation Timings

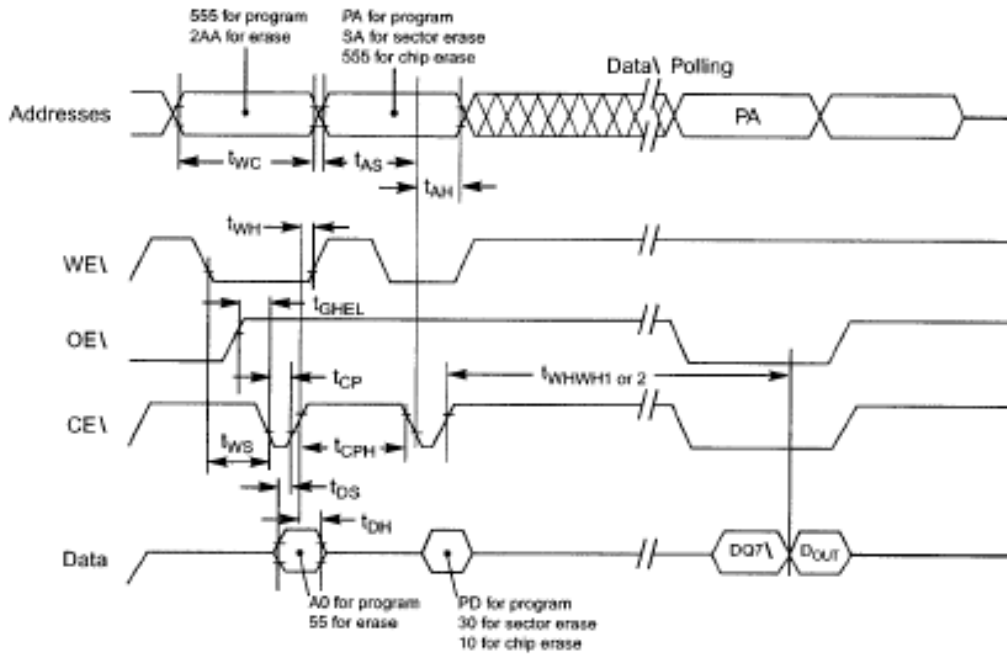

NOTES:

1. PA = Program Address, PD = Program Data, SA = Sector Address, DQ7\ = Complement of Data Input, D_{OUT} = Array Data.
2. Figure indicates the last two bus cycles of the command sequence.

ERASE AND PROGRAMMING PERFORMANCE

PARAMETER	LIMITS			COMMENTS
	TYP ¹	MAX ²	UNIT	
Sector Erase Time	1	8	sec	Excludes 00h programming prior to erasure ⁴
Chip Erase Time	8	64	sec	
Byte Programming Time	7	300	µs	Excludes system-level overhead ⁵
Chip Programming Time ³	3.6	10.8	sec	

NOTES:

1. Typical program and erase times assume the following conditions: 25°C, 5.0V V_{CC} , 1 million cycles. Additionally, programming typicals assume checkerboard pattern.
2. Under worst case conditions of 90°C, $V_{CC} = 4.5V$; 1,000,000 cycles.
3. The typical chip programming time is considerably less than the maximum chip programming time listed, since most bytes program faster than the maximum byte program time listed. If the maximum byte program time given is exceeded, only then does the device set DQ5 = 1. See the section on DQ5 for further information.
4. In the pre-programming step of the Embedded Erase algorithm, all bytes are programmed to 00h before erasure.
5. System-level overhead is the time required to execute the four-bus-cycle command sequence for programming. See Table 4 for further information on command definitions.
6. The device has a minimum guaranteed erase and program cycle endurance of 1 million cycles.

LATCHUP CHARACTERISTIC

PARAMETER	MIN	MAX
Input voltage with respect to V_{SS} on all I/O pins	-1.0V	$V_{CC} + 1.0V$
V_{CC} Current	-100mA	+100mA

NOTES: Includes all pins except V_{CC} . Test conditions: $V_{CC} = 5.0V$, one pin at a time.

PIN CAPACITANCE

PARAMETER	CONDITIONS	SYMBOL	TYP	MAX	UNIT
Input Capacitance	$V_{IN} = 0$	C_{IN}	4	6	pF
Output Capacitance	$V_{OUT} = 0$	C_{OUT}	8	12	pF
Control Pin Capacitance	$V_{PP} = 0$	C_{IN2}	8	12	pF

NOTES:

1. Sampled, not 100% tested.
2. Test conditions $T_A = 25^\circ C$, $f = 1.0$ MHz

DATA RETENTION

PARAMETER	CONDITIONS	MIN	UNIT
Minimum Pattern Data Retention Time	150°C	10	Years
	125°C	20	Years

MECHANICAL DEFINITIONS*

ASI Case (Package Designator CW)
SMD 5962-96692, Case Outline X

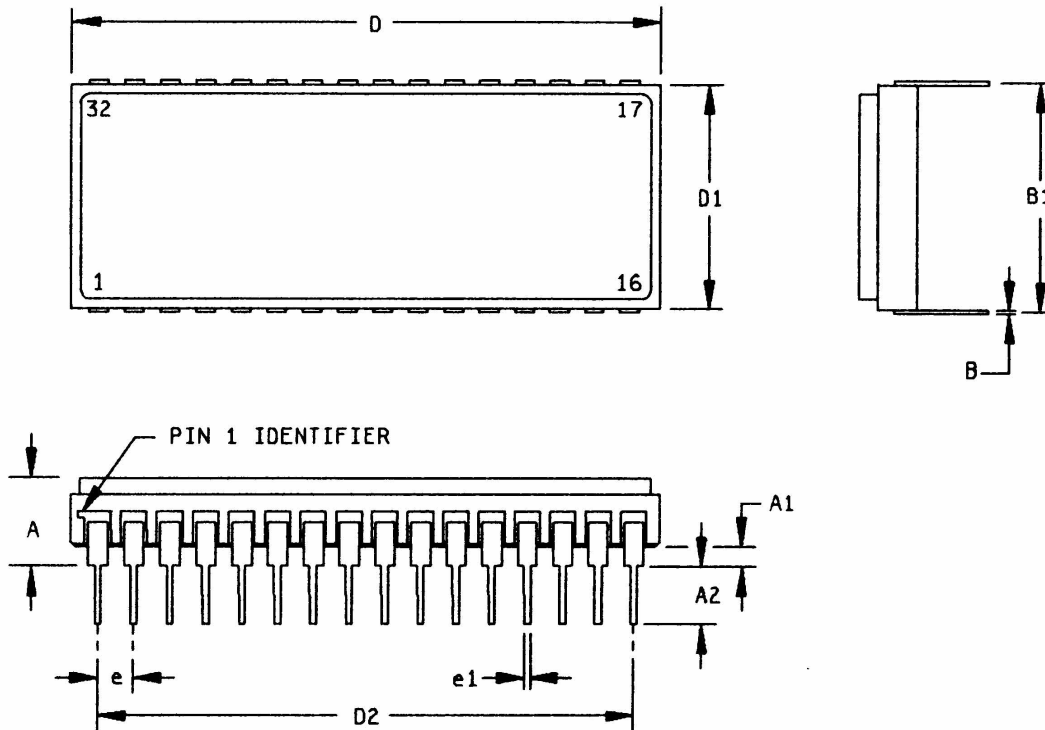

SYMBOL	SMD SPECIFICATIONS	
	MIN	MAX
A	0.140	0.200
A1	0.019	0.047
A2	0.125	0.193
B	0.009	0.012
B1	0.588	0.617
D	1.654	1.686
D1	0.580	0.605
D2	1.492	1.508
e	0.100 BSC	
e1	0.016	0.020

*All measurements are in inches.

MECHANICAL DEFINITIONS*

ASI Case (Package Designator F)
SMD 5962-96692, Case Outline U

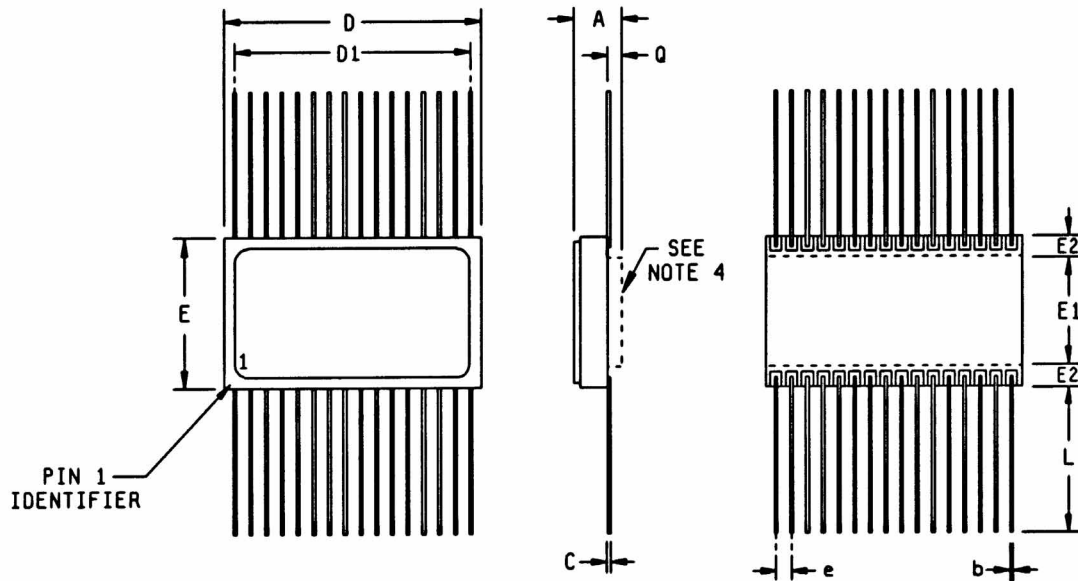

SYMBOL	SMD SPECIFICATIONS	
	MIN	MAX
A	---	0.125
b	0.015	0.019
C	0.004	0.007
D	0.810	0.830
D1	0.750 TYP	
E	0.405	0.415
E1	0.305	0.315
E2	0.050 TYP	
e	0.050 TYP	
L	0.380	0.420
Q	0.022	0.028

*All measurements are in inches.

MECHANICAL DEFINITIONS*

ASI Case (Package Designator DCG)
SMD 5962-96692, Case Outline T

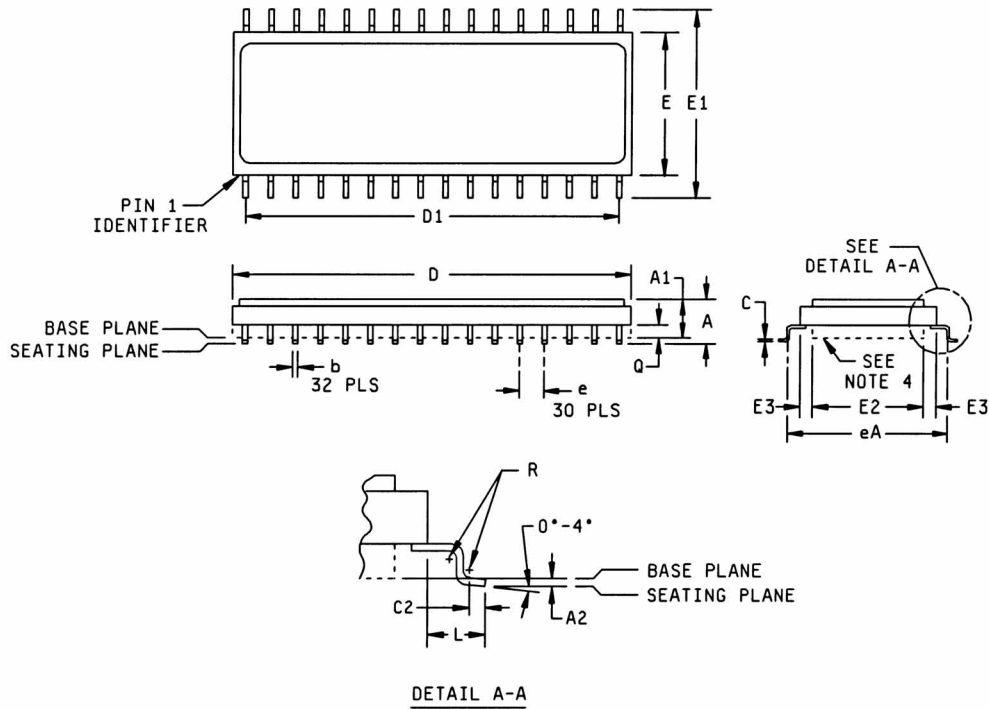

DETAIL A-A

SYMBOL	SMD SPECIFICATIONS	
	MIN	MAX
A	---	0.132
A1	0.095	0.125
A2	0.003	0.007
b	0.015	0.019
C	0.004	0.007
C2	0.030 TYP	
D	0.810	0.830
D1	0.750 TYP	
E	0.405	0.415
E1	0.525	0.535
E2	0.305	0.315
E3	0.050 TYP	
e	0.050 TYP	
eA	0.436 TYP	
L	0.060 TYP	
Q	0.022	0.028
R	0.007 TYP	

*All measurements are in inches.

MECHANICAL DEFINITION*

ASI Case #208 (Package Designator ECA)

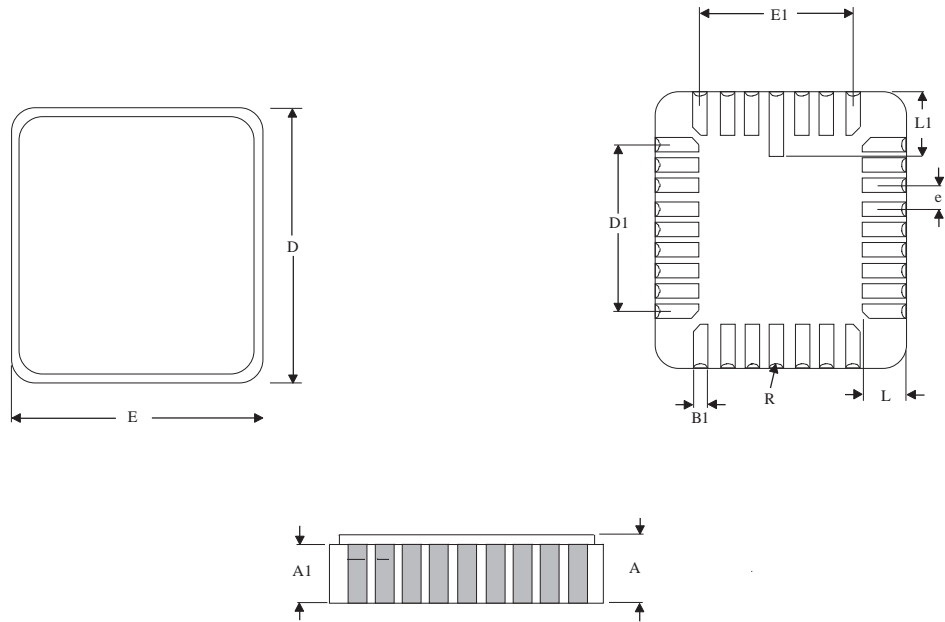

SYMBOL	SMD SPECIFICATIONS	
	MIN	MAX
A	0.060	0.080
A1	0.040	0.050
B1	0.022	0.028
D	0.540	0.560
D1	0.390	0.410
E	0.442	0.458
E1	0.290	0.310
e	0.045	0.055
L	0.045	0.055
L1	0.075	0.095
R	0.004	0.014

*All measurements are in inches.

ORDERING INFORMATION

EXAMPLE: AS29F040CW-55/883C

Device Number	Package Type	Speed ns	Process
AS29F040	CW	-55	/*
AS29F040	CW	-60	/*
AS29F040	CW	-70	/*
AS29F040	CW	-90	/*
AS29F040	CW	-120	/*
AS29F040	CW	-150	/*

EXAMPLE: AS29F040F-60/XT

Device Number	Package Type	Speed ns	Process
AS29F040	F	-55	/*
AS29F040	F	-60	/*
AS29F040	F	-70	/*
AS29F040	F	-90	/*
AS29F040	F	-120	/*
AS29F040	F	-150	/*

EXAMPLE: AS29F040DCG-70/Q

Device Number	Package Type	Speed ns	Process
AS29F040	DCG	-55	/*
AS29F040	DCG	-60	/*
AS29F040	DCG	-70	/*
AS29F040	DCG	-90	/*
AS29F040	DCG	-120	/*
AS29F040	DCG	-150	/*

EXAMPLE: AS29F040ECA-90/Q

Device Number	Package Type	Speed ns	Process
AS29F040	ECA	-55	/*
AS29F040	ECA	-60	/*
AS29F040	ECA	-70	/*
AS29F040	ECA	-90	/*
AS29F040	ECA	-120	/*
AS29F040	ECA	-150	/*

***AVAILABLE PROCESSES**
 XT = Military Temperature Range
 IT = Industrial Temperature Range
 883C = 883C Processing
 Q = QML Processing

Temperature
 -55°C to +125°C
 -40°C to +85°C
 -55°C to +125°C
 -55°C to +125°C

ASI TO DSCC PART NUMBER CROSS REFERENCE*

ASI Package Designator CW

<u>ASI Part #</u>	<u>SMD Part #</u>
AS29F040CW-55/Q	5962-9669206HXA
AS29F040CW-60/Q	5962-9669205HXA
AS29F040CW-70/Q	5962-9669204HXA
AS29F040CW-90/Q	5962-9669203HXA
AS29F040CW-120/Q	5962-9669202HXA
AS29F040CW-150/Q	5962-9669201HXA

ASI Package Designator F

<u>ASI Part #</u>	<u>SMD Part #</u>
AS29F040F-55/Q	5962-9669206HUA
AS29F040F-60/Q	5962-9669205HUA
AS29F040F-70/Q	5962-9669204HUA
AS29F040F-90/Q	5962-9669203HUA
AS29F040F-120/Q	5962-9669202HUA
AS29F040F-150/Q	5962-9669201HUA

ASI Package Designator DCG

<u>ASI Part #</u>	<u>SMD Part #</u>
AS29F040DCG-55/Q	5962-9669206HTA
AS29F040DCG-60/Q	5962-9669205HTA
AS29F040DCG-70/Q	5962-9669204HTA
AS29F040DCG-90/Q	5962-9669203HTA
AS29F040DCG-120/Q	5962-9669202HTA
AS29F040DCG-150/Q	5962-9669201HTA

ASI Package Designator ECA

<u>ASI Part #</u>	<u>SMD Part #</u>
AS29F040ECA-55/Q	5962-9669206H_A
AS29F040ECA-60/Q	5962-9669205H_A
AS29F040ECA-70/Q	5962-9669204H_A
AS29F040ECA-90/Q	5962-9669203H_A
AS29F040ECA-120/Q	5962-9669202H_A
AS29F040ECA-150/Q	5962-9669201H_A

* ASI part number is for reference only. Orders received referencing the SMD part number will be processed per the SMD.