

Series 801 Cordsets For Harsh Environments



Overmolded Cordset

Glenair's "Mighty Mouse" overmolded cordsets offer watertight sealing and excellent cold temperature flexibility. These cables are 100% tested and ready to use. Standard overmolded cables feature polyurethane jackets with flexible strain reliefs.

Two Jacket Types – standard extruded Estane polyurethane jacket resists abrasion and chemicals. Or choose low smoke / zero halogen polyurethane jackets for compliance with low toxicity regulations.

Shielded – These cables feature 90% tinned copper braid coverage. Shields are terminated directly to connectors with **BAND-IT®** straps.

Simplified Ordering, No Minimums
ASAP cordsets are made-to-order from stocked connectors and cable. Choose #22 or #24 AWG cable with standard Estane jacket for best availability.

HOW TO ORDER

Sample Part Number

801-025	-A	C	4	M	7-10	P	A	-72	
Series	End A Connector	End B Connector	Wire Size	Shell Material / Finish	Insert Arr.	Protective Cover	Shell Key Pos.	Length	
801-025 Overmolded Cordset, Shielded, with Polyurethane Cable Jacket	-A Plug, with Male Pin Contacts	A Plug, with Male Pin Contacts	2 #22 AWG (Std.)	C Aluminum / Black Anodize	5-3 3 #23 6-4 4 #23 6-7 7 #23	P Metal Protective Covers Included	A Normal	Overall Length In Inches	
	-B Plug, with Female Socket Contacts	B Plug, with Female Socket Contacts	4 #24 AWG (Std.)	M Aluminum / Electroless Nickel	7-10 10 #23 8-13 13 #23 9-19 19 #23		B Pos. B	12 Inch Min.	
	-C Receptacle, with Male Pin Contacts	C Receptacle, with Male Pin Contacts	6 #26 AWG	NF Aluminum / Cadmium with Olive Drab Chromate	10-26 26 #23 13-37 37 #23 16-55 55 #23 17-85 85 #23		N No Covers Supplied	C Pos. C	
	-D Receptacle, with Female Socket Contacts	D Receptacle, with Female Socket Contacts	8 #28 AWG	ZN Aluminum / Zinc-Nickel with Olive Drab Chromate				D Pos. D	
801-026 Overmolded Cordset, Shielded, with Low Smoke/ Zero Halogen Polyurethane Jacket		N No Connector (Single-Ended)		ZNU Aluminum / Zinc-Nickel with Black Chromate					
				Z1 Stainless Steel / Passivated					

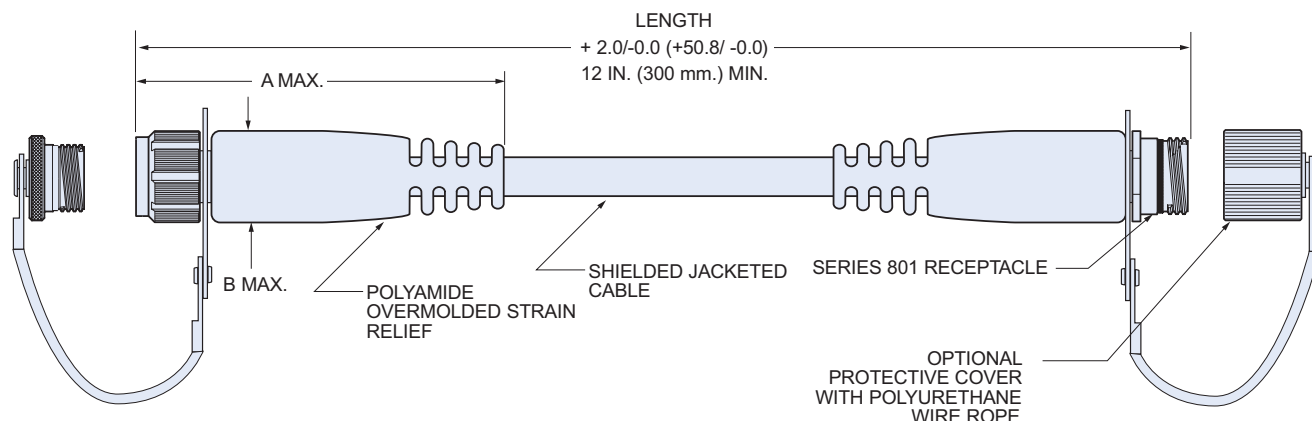

RIGHT ANGLE CORDSETS

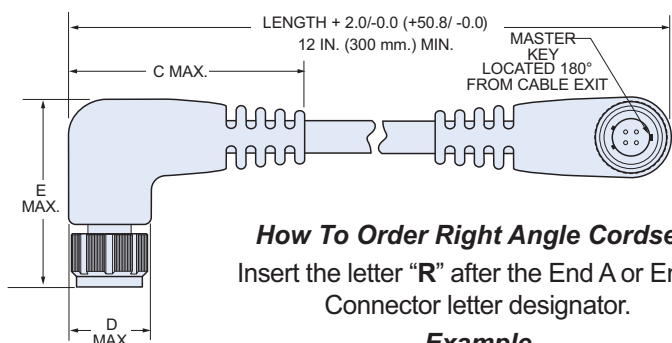

How To Order Right Angle Cordsets

Insert the letter "R" after the End A or End B Connector letter designator.

Example

Straight cable 801-025-AC4Z16-4PA-72
Right Angle 801-025-ARCR4Z16-4PA-72

DIMENSIONS

Shell Size	A Max.		B Max.		C Max.		D Max.		E Max.	
	In.	mm.	In.	mm.	In.	mm.	In.	mm.	In.	mm.
5	2.000	50.80	.490	12.45	1.500	38.10	.490	12.45	1.650	41.91
6	2.500	63.50	.560	14.22	1.500	38.10	.560	14.22	1.650	41.91
7	2.500	63.50	.680	17.27	1.700	43.18	.680	17.27	1.700	43.18
8	2.500	63.50	.740	18.80	1.750	44.45	.740	18.80	1.750	44.45
9	2.500	63.50	.810	20.57	1.750	44.45	.810	20.57	1.750	44.45
10	2.750	69.85	.870	22.10	1.750	44.45	.870	22.10	1.750	44.45
13	3.000	76.20	.930	23.62	1.750	44.45	.930	23.62	1.750	44.45
16	3.500	88.90	1.120	28.45	1.750	44.50	1.120	28.45	1.750	44.45
17	3.750	95.25	1.180	29.97	2.000	50.80	1.180	29.97	2.000	50.80

SERIES 801 HARSH ENVIRONMENT CORDSET SPECIFICATIONS

Cable Jacket Material	Thermoplastic Polyurethane, Black, UL 94 V-0 Rated
Cable Shield	Tin-Coated Copper Braid, 90% Minimum Coverage
Conductors	Silver Coated Stranded Wire, TFE Insulated, Per M22759/11
BAND-IT® Shield Termination Band	Stainless Steel
Current Rating	Up to 5 AMP Continuous Duty With #22 AWG Wire
Test Voltage (Dielectric Withstanding Voltage)	500 VAC RMS sea level, 100 VAC RMS 70,000 feet
Insulation Resistance	200 megohms minimum
Operating Temperature	-30° C. to +105° C.
Immersion	1 meter water immersion for 1 Hour per MIL-STD-810 Method 512
Solvent Resistance, Polyamide Overmold	Excellent Resistance to Most Solvents, Fuels, and Oils; Poor Resistance to Strong Acids and Bipolar Solvents (Alcohol)
Electrical Resistance	(8 Milliohms Mated Contacts) + (Wire Resistance)
Shielding Effectiveness	50 dB minimum from 100MHz to 1000MHz.
Flammability and Toxicity (LSZH Jacket)	Toxicity Index 3.9 per NES 713 Oxygen Index 28% per ASTM D-2863 Smoke Index 24 per NES 711