

Silicon NPN Power Transistors

2SD1417

DESCRIPTION

- With TO-220Fa package
- High DC current gain
- Low saturation voltage
- Complement to type 2SB1022
- DARLINGTON

APPLICATIONS

- Power amplifier and switching applications
- Hammer drive,pulse motor drive applications

PINNING

PIN	DESCRIPTION
1	Base
2	Collector
3	Emitter

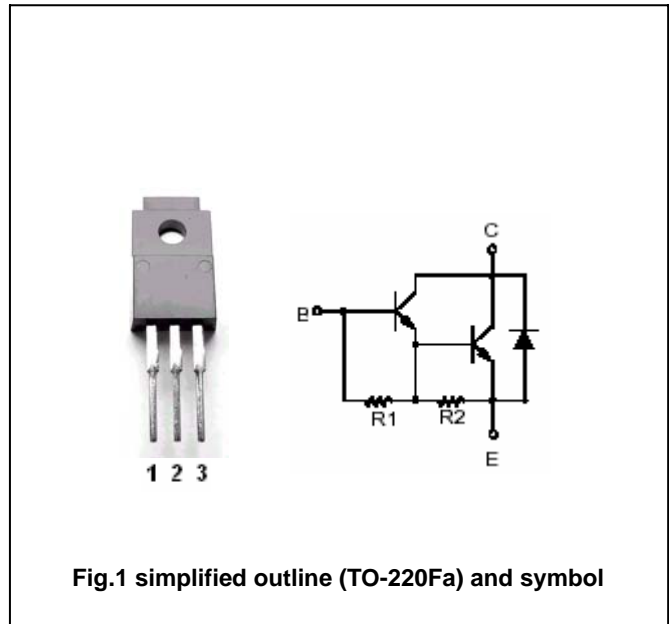

Fig.1 simplified outline (TO-220Fa) and symbol

Absolute maximum ratings(Ta=25°C)

SYMBOL	PARAMETER	CONDITIONS	VALUE	UNIT
V_{CBO}	Collector-base voltage	Open emitter	60	V
V_{CEO}	Collector -emitter voltage	Open base	60	V
V_{EBO}	Emitter-base voltage	Open collector	5	V
I_C	Collector current		7	A
I_B	Base current		0.2	A
P_C	Collector power dissipation	$T_C=25^{\circ}C$	30	W
		$T_a=25^{\circ}C$	2.0	
T_j	Junction temperature		150	°C
T_{stg}	Storage temperature		-55~150	°C

Silicon NPN Power Transistors

2SD1417

CHARACTERISTICS

T_j=25°C unless otherwise specified

SYMBOL	PARAMETER	CONDITIONS	MIN	TYP.	MAX	UNIT
V _{(BR)CEO}	Collector-emitter breakdown voltage	I _C =50mA; I _B =0	60			V
V _{CEsat-1}	Collector-emitter saturation voltage	I _C =3A ; I _B =6mA		0.9	1.5	V
V _{CEsat-2}	Collector-emitter saturation voltage	I _C =7A ; I _B =14mA		1.2	2.0	V
V _{BEsat}	Base-emitter saturation voltage	I _C =3A ; I _B =6mA		1.5	2.5	V
I _{CBO}	Collector cut-off current	V _{CB} =60V; I _E =0			100	μ A
I _{EBO}	Emitter cut-off current	V _{EB} =5V; I _C =0			3.0	mA
h _{FE-1}	DC current gain	I _C =3A ; V _{CE} =3V	2000		15000	
h _{FE-2}	DC current gain	I _C =7A ; V _{CE} =3V	1000			

Switching times

t _{on}	Turn-on time	I _{B1} =-I _{B2} =6mA V _{CC} ≈45V , R _L =15Ω		0.8		μ s
t _{stg}	Storage time			3.0		μ s
t _f	Fall time			2.5		μ s

PACKAGE OUTLINE

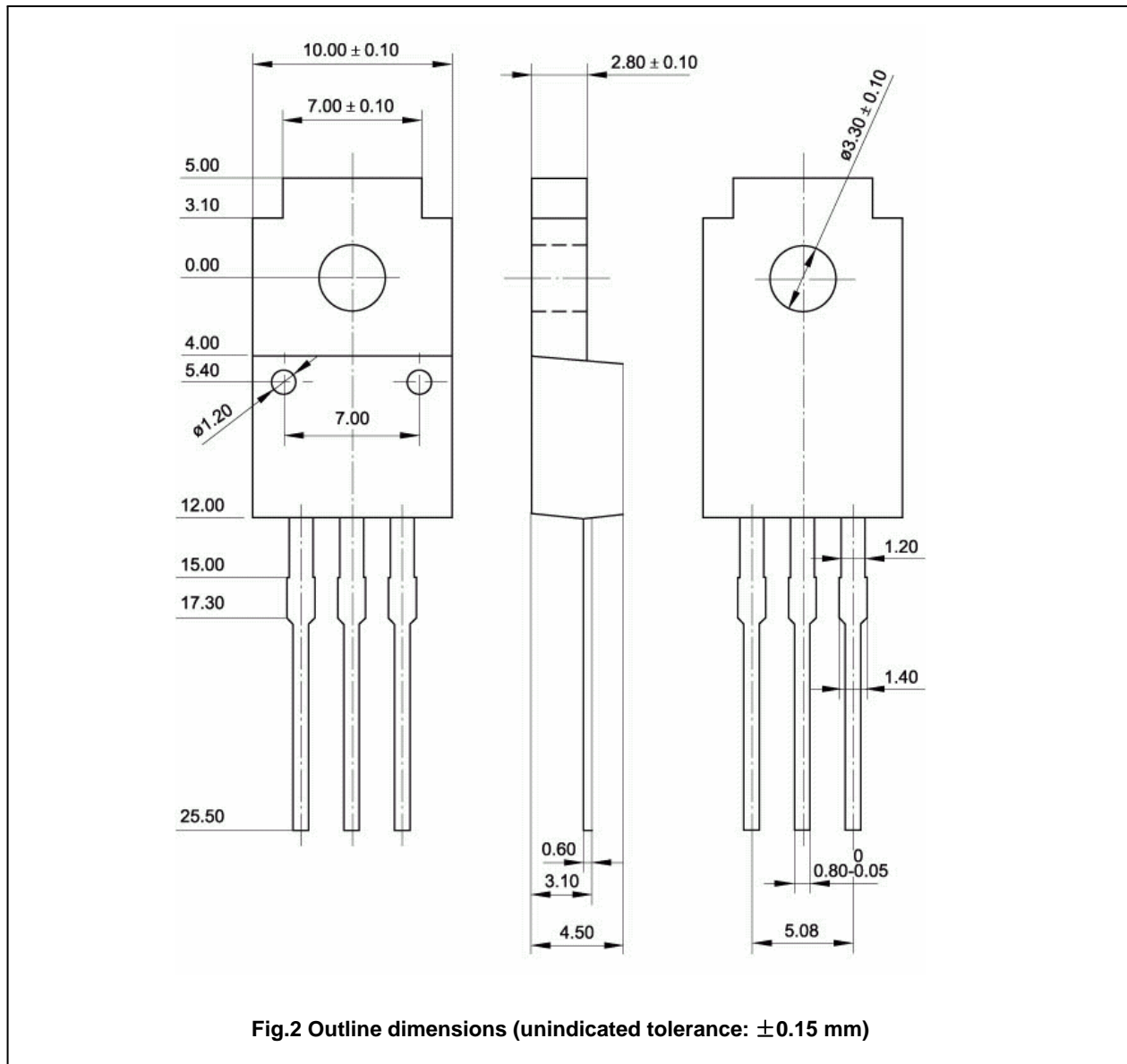

Fig.2 Outline dimensions (unindicated tolerance: ± 0.15 mm)