

Series 240-804 "Mighty Mouse" Filter Connector
Push-Pull Quick Disconnect
 Master How to Order • Part Number Breakdown

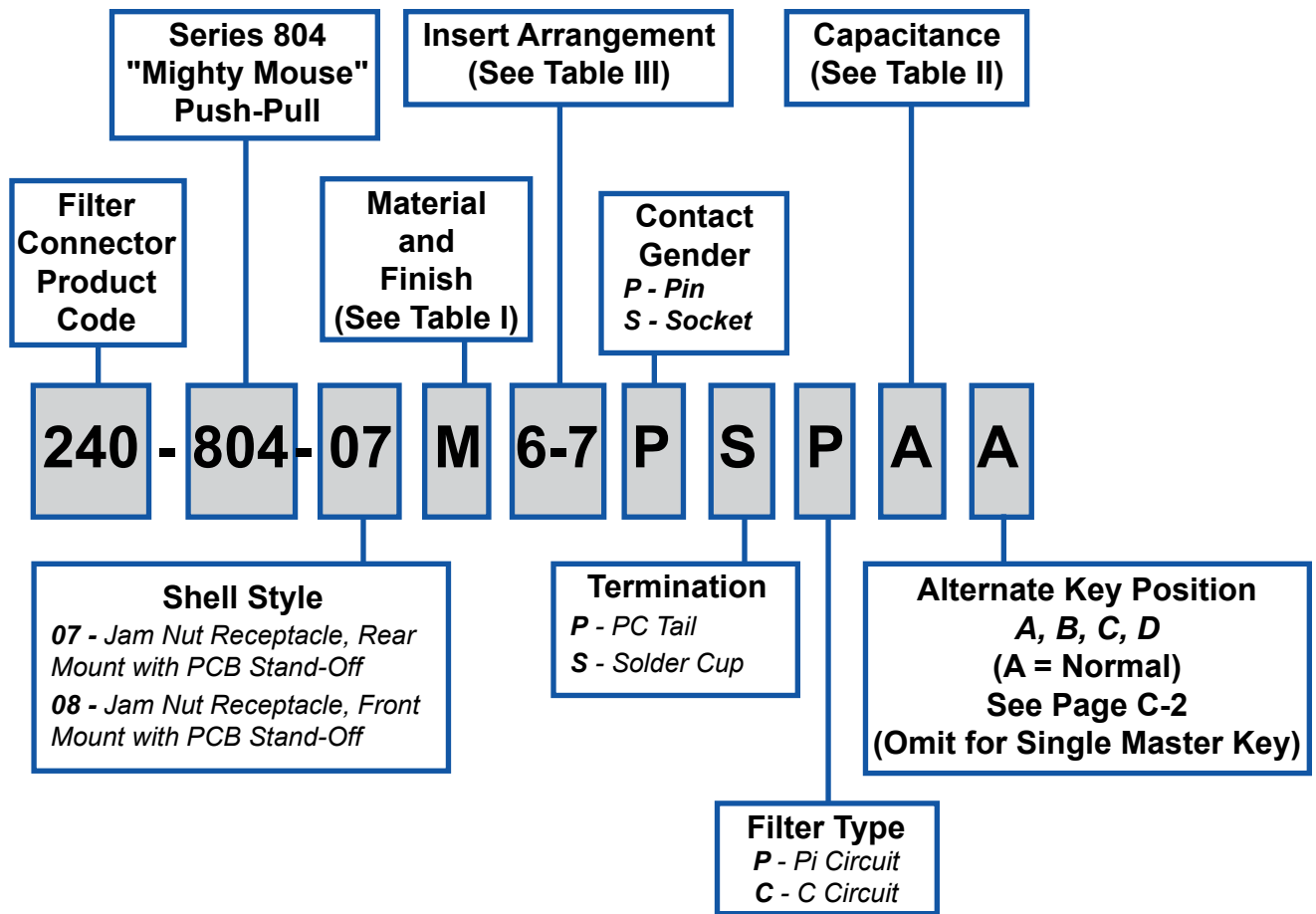

SYM	MATERIAL	FINISH DESCRIPTION
M	Aluminum	Electroless Nickel
MT	Aluminum	Ni-PTFE 1000 Hour Grey™ (Nickel Fluorocarbon Polymer)
NF	Aluminum	Cadmium O.D. Over Electroless Nickel
P	Stainless Steel	Electro-Deposited Nickel
ZN	Aluminum	Zinc-Nickel Over Electroless Nickel

CLASS	PI - CIRCUIT (pF)	C - CIRCUIT (pF)
A	38,000 - 56,000	19,000 - 28,000
B	32,000 - 45,000	16,000 - 22,500
C	18,000 - 33,000	9,000 - 16,500
D	8,000 - 12,000	4,000 - 6,000
E	3,300 - 5,000	1,650 - 2,500
F	800 - 1,300	400 - 650
G	400 - 600	200 - 300

Arr. No.	Contact Size	Contact Qty.
5-3	23	3
6-1	16	1
6-4	23	4
6-7	23	7
7-1	12	1
7-10	23	10
8-13	23	13
9-4	16	4
9-19	23	19
10-26	23	26
12-2	12	2
12-37	23	37
14-55	23	55
15-85	23	85



240-804-07 and -08
"Mighty Mouse" Filter Connector
 Push-Pull Quick Disconnect
 Printed Circuit Board Versions with PCB or Solder Cup Contacts

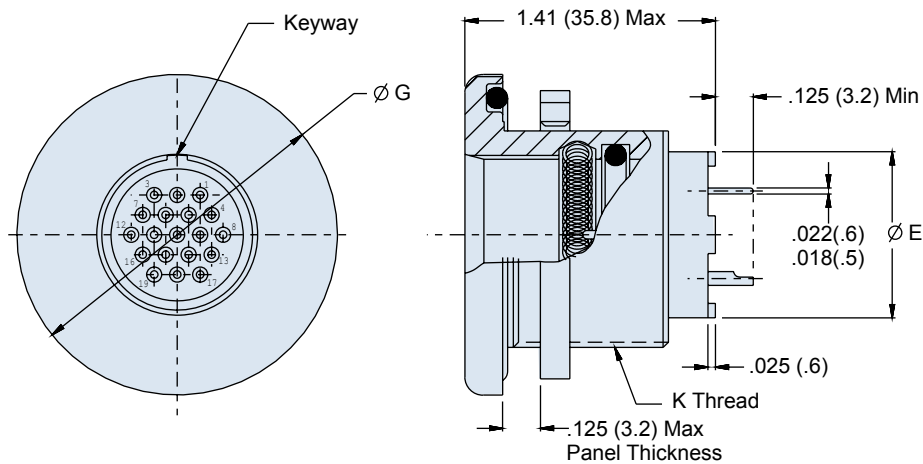
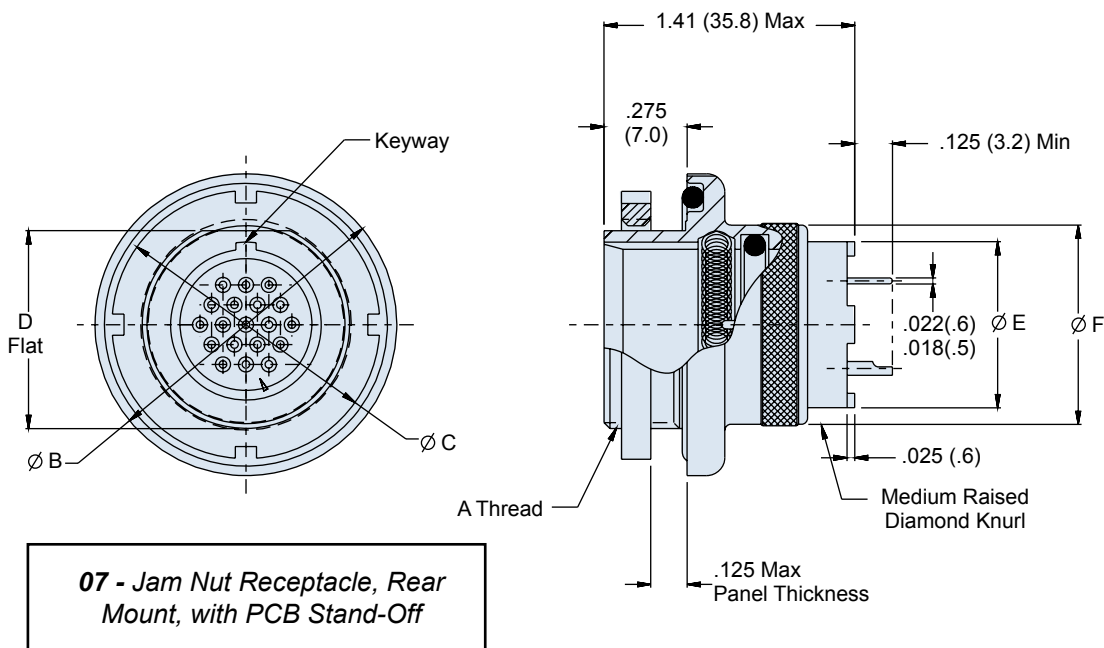

240-804-07 and -08
"Mighty Mouse" Filter Connector
Push-Pull Quick Disconnect
Printed Circuit Board Versions with PCB or Solder Cup Contacts



Series 80
Mighty Mouse

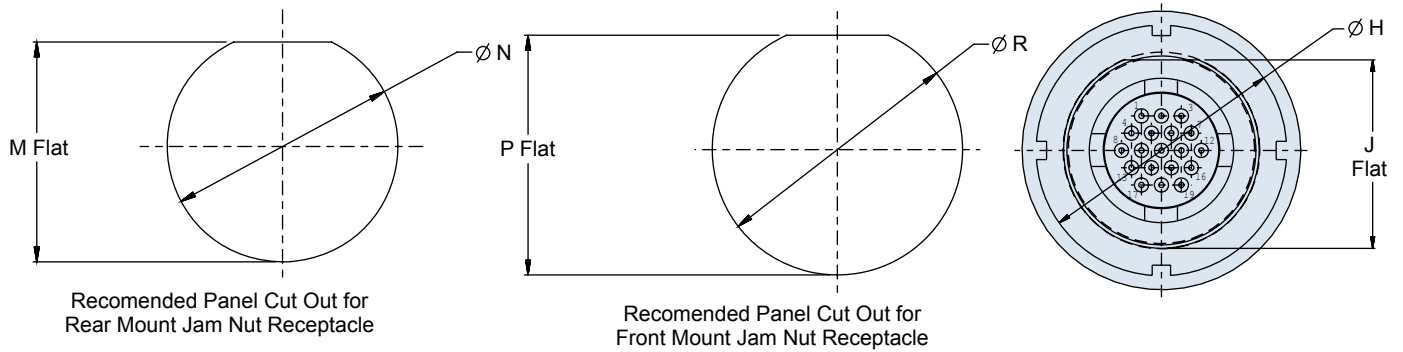

C

TABLE II: DIMENSIONS

SHELL SIZE	A THREAD	Ø B	Ø C	D FLAT	Ø E	Ø F	Ø G	Ø H	J FLAT	K THREAD	M FLAT	Ø N	P FLAT	Ø R
5	.4375-32 UN-2A	.790	.660	.415	.348	.450	.830	0.730	.470	.5000-32 UN-2A	.427 (10.8)	.448	.482 (12.2)	.510
		(20.1)	(16.8)	(10.5)	(8.8)	(11.4)	(21.1)	(18.5)	(11.9)		.423 (10.7)	(11.4)	.478 (12.1)	(13.0)
6	.5000-32 UN-2A	.830	.720	.467	.413	.520	.885	.780	.530	.5625-28 UN-2A	.479 (12.2)	.510	.542 (13.8)	.575
		(21.1)	(18.3)	(11.9)	(10.5)	(13.2)	(22.5)	(19.8)	(13.5)		.475 (12.1)	(13.0)	.538 (13.7)	(14.6)
7	.6250-28 UN-2A	.910	.835	.594	.461	.580	.995	.920	.663	.6875-28 UN-2A	.606 (15.4)	.635	.676 (17.2)	.698
		(23.1)	(21.2)	(15.1)	(11.7)	(14.7)	(25.3)	(23.4)	(16.8)		.601 (15.3)	(16.1)	.671 (17.0)	(17.7)
8	.6250-28 UN-2A	.955	.836	.594	.493	.603	.995	.920	.663	.6875-28 UN-2A	.606 (15.4)	.635	.676 (17.2)	.698
		(24.3)	(21.2)	(15.1)	(12.5)	(15.3)	(25.3)	(23.4)	(16.8)		.602 (15.3)	(16.1)	.671 (17.0)	(17.7)
9	.6875-32 UN-2A	1.000	.900	.655	.551	.695	1.075	.970	.720	.7500-28 UN-2A	.667 (16.9)	.695	.732 (18.6)	.760
		(25.4)	(22.9)	(16.6)	(14.0)	(17.7)	(27.3)	(24.6)	(18.3)		.663 (16.8)	(17.7)	.728 (18.5)	(19.3)
10	.7500-28 UN-2A	1.085	.950	.721	.655	.735	1.140	1.040	.788	.8125-28 UN-2A	.734 (18.6)	.760	.801 (20.3)	.822
		(27.6)	(24.1)	(18.3)	(16.6)	(18.7)	(29.0)	(26.4)	(20.0)		.729 (18.5)	(19.3)	.796 (20.2)	(20.9)
12	.8750-28 UN-2A	1.180	1.080	.843	.703	.880	1.340	1.230	.970	1.000-28 UN-2A	.855 (21.7)	.885	.982 (24.9)	1.010
		(30.0)	(27.4)	(21.4)	(17.9)	(22.4)	(34.0)	(31.2)	(24.6)		.851 (21.6)	(22.5)	.978 (24.8)	(25.7)
14	1.0000-28 UN-2A	1.325	1.210	.968	.863	1.010	1.390	1.280	1.020	1.062-20 UN-2A	.980 (24.9)	1.010	1.032 (26.2)	1.075
		(33.7)	(30.7)	(24.6)	(21.9)	(25.7)	(35.3)	(32.5)	(25.9)		.976 (24.8)	(25.7)	1.028 (26.1)	(27.3)
15	1.125-28 UN-2A	1.390	1.280	1.029	.912	1.060	1.450	1.340	1.093	1.125-28 UN-2A	1.041 (26.4)	1.070	1.015 (25.8)	1.135
		(35.3)	(32.5)	(26.1)	(23.2)	(26.9)	(36.8)	(34.0)	(27.8)		1.037 (26.3)	(27.2)	1.011 (25.7)	(28.8)