

- **HIGH POWER DENSITY**
- **S:7Pin SIP PACKAGE**
- **D:14Pin DIP PACKAGE**
- **SINGLE OUTPUT VOLTAGE**
- **INDUSTRIAL STANDARD PIN-OUT**
- **NO HEAT SINK REQUIRED**
- **1KVAC ISOLATION**
- **REGULATED OUTPUT VOLTAGE**
- **PCB MOUNTING**

ELECTRICAL SPECIFICATIONS:

(All specifications tested typically @ 25°C, humidity<75%, nominal input and rated output unless otherwise noted.)

OUTPUT SPECIFICATIONS

Items:	Testing condition	Min	Typ	Max
Output accuracy:	At full load and nominal Vin			±2%
Output power:				1W
Line regulation:	Input voltage from low to full load	+/-0.5%max.(3.3 VDC output +/- 1 % max)		
Load regulation:	From 0% to full load		0.5%	+/- 1 %
Ripple and noise:	20MHz bandwidth			30mVp-p
Temperature drift:				±0.02 %/°C
Switching frequency			100K HZ	
Short circuit protection		Continue protection>30s		

INPUT SPECIFICATIONS

Items:	Testing condition	Min	Typ	Max
Voltage range			+/- 20%	
Filter			Pi	

COMMON SPECIFICATIONS

Items		Min	Typ.	Max
Operating temperature range		-40°C		+65°C
Storage temperature range		-55°C		+125°C
Humidity				<90%
Cooling	Free Air Convection			
Leak current	1mA			
Isolation voltage (VDC)	Input to Output		1,000	
Isolation resistance (ohms)			10 ⁹	
Isolation capacitance (pF)				60
Efficiency (%)	See Product List	55		75
Case material	Non-conductive black plastic			

VBXXXXS/D-1W DC-DC CONVERTER

Potting material	Epoxy Resin UL94-V0
Packing material	Tube
Dimension (mm / inch)	SIP: 19.6*6.0*10(0.77*0.24*0.40) DIP: 20.4*10*8.2(0.8*0.4*0.32)
Weight (g)	10
MTBF (Hrs)	>1,000,000

PRODUCT LIST

Part Number	Input Voltage (VDC)			Output		Efficiency (%, Typ.)	Package
	Range	Nominal	Max.	Max Current (mA)	Voltage (VDC)		
VB0503S-1W	4.5-5.5	5	7.25	200	3.3	68	SIP
VB0505S-1W	4.5-5.5	5	7.25	200	5	67	SIP
VB0512S-1W	4.5-5.5	5	7.25	84	12	72	SIP
VB1205S-1W	10.8-13.2	12	16.0	200	5	64	SIP
VB1212S-1W	10.8-13.2	12	16.0	84	12	68	SIP
VB1209S-1W	10.8-13.2	24	16.0	111	15	68	SIP
VB2405S-1W	21.6-26.4	24	30.0	200	5	68	SIP
VB2409S-1W	21.6-26.4	24	30.0	111	9	66	SIP
VB2412S-1W	21.6-26.4	24	30.0	84	12	77	SIP
VB0512D-1W	4.5-7.25	5	7.25	84	12	72	DIP
VB1205D-1W	10.8-13.2	12	16.0	200	5	69	DIP
VB2405D-1W	21.6-26.4	24	30.0	200	5	68	DIP
VB2409D-1W	21.6-26.4	24	16.0	111	9	68	DIP

Connecting DC-DC Converters in Series

Galvanic isolation of the output allows multiple converters to be connected in series simply by connecting the positive output of one converter to the negative of another (see figure 1). In this way, non-standard voltage rails can be generated, however, the current output of the highest output voltage converter should not be exceeded. When converters are connected in series, additional filtering is strongly recommended as the converters switching circuits are not synchronized. As well as a summation of the ripple voltages, the output could also produce relatively large beat frequencies. A capacitor across the output will help, as will a series inductor.

Connecting DC-DC Converters in Parallel

If the available power output from a single converter is inadequate for the application, then multiple converters can be paralleled to produce a higher output power. However, it is not recommended to parallel converters to generate a higher power output, please select our higher power output modules or contact us for a customized solution.

It should be noted that it is always preferable to parallel multiple converters of the same type. For instance, if a 2.5W converter is required, then either 2pcs [AxxxxS-2W](#) should be used or 3 [AxxxxS-1W](#), not an [AxxxxS-2W](#) and an [AxxxxS-1W](#). The reason for this is that the output voltages are not sufficiently well matched to guarantee that an [AxxxxS-2W](#) would supply twice as much as an [AxxxxS-1W](#) and the situation would occur where there was only 1W being drawn from the [AxxxxS-2W](#) and 1.5W from [AxxxxS-1W](#). Even with paralleled converters of the same type, loading will be uneven, however, there is only likely to be around a 10% difference in output load when the output voltages are well matched.

When connecting converter outputs, it should be remembered that the switching will not be synchronous, hence some form of coupling should be employed. One possible solution is to use a diode feed, this is suitable mainly for 12V and 15V output types only where the diode voltage drop (typically 0.6V) will not significantly affect the circuit functionality (see figure 2). With 5V and 9V supplies the diode drop is generally too large to consider as a suitable means of connecting paralleled converters. This method also

VBXXXXS/D-1W DC-DC CONVERTER

has a beat frequency that will superimpose itself over the ripple of the two converters, this can be reduced by using an external capacitor at the paralleled output. The preferred method of connecting converters in parallel is via series inductors on the output (see figure 3). This configuration not only has a lower loss of voltage than the diode method, but by suitable choice of inductor and an additional external capacitor, the beat frequency can be significantly reduced, as will the ripple from each converter. Suitable values are given in the table below (see table 1), these typically reduce the beat and ripple frequencies by a factor of 10.

Isolation

One of the main features of the majority of Sunyuan components DC-DC converters is the high galvanic isolation capability. This allows several variations on circuit topography by using a single DC-DC converter. The basic input to output isolation can be used to provide either a simple isolated output power source, or to generate different voltage rails and /or dual polarity rails. These configurations are most often found in data processing, instrumentation and other noise sensitive circuits where it is necessary to isolate the load and noise presented to the local power supply rails from that of an entire system. Usually local supply noise appears as common mode noise at the converter and does not pollute the main system power supply rails. The isolated positive output can be connected to the input ground rail to generate a negative supply rail if required. Since the output is isolated from the input the choice of reference for the output side can be relatively arbitrary, for example an additional single rail can be generated above the main supply rail or offset by some other DC value.

Regulated converters need more consideration than the unregulated type for mixing the reference level. Essentially the single supply rail has a regulator in its positive output rail only, hence referring the isolated ground will only work if all the current return is through the DC-DC and not via other external components, such as diode bias, resistor feed. Have an alternative return path can upset the regulation and the performance of the system may not equal that of the converter. In one word, the isolation features are to generate two completely independent power supply but also united perfectly through the modern technology. This has been widely used in the application of mixed circuits, A/D, D/A and other circuits that are sensitive to noise.

Filtering

All Sunyuan isolated DC-DC Converters have a fixed characteristic frequency at which the device operates. This fixed frequency allows filtering that is relatively simple compared to pulse-skipping types. In a pulse-skipping converter a large range of frequencies are encountered as the device adjusts the pulse interval for loading conditions.

NOMENCLATURE

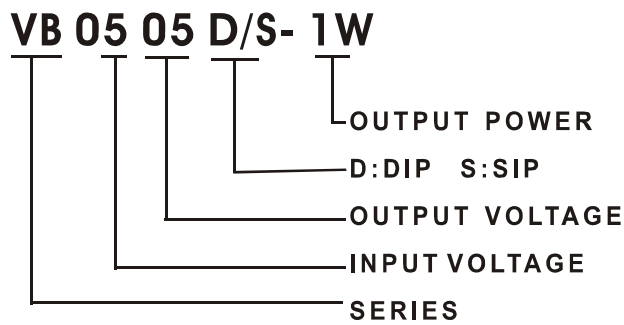

TEMPERATURE DERATING GRAPH

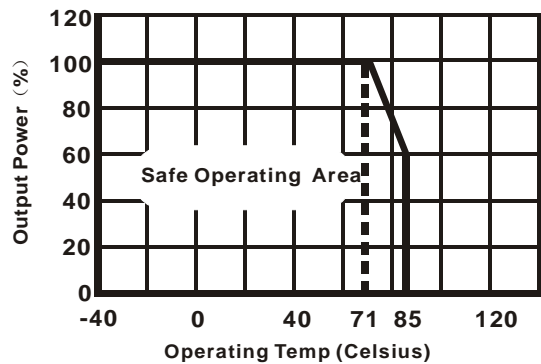

TYPICAL CONNECTION

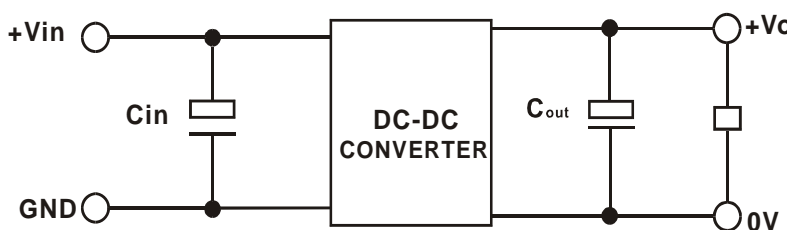

OUTLINE DIMENSION

SIZE	SIP(LxWxH)	DIP(LxWxH)
1W	19.6x6.0x10	20.4x10x6.5
2W	19.6x7.0x10	20.4x10x6.5

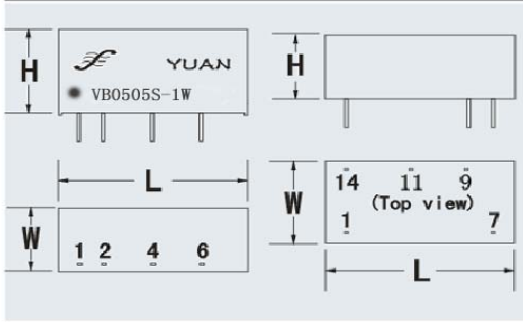

PKG	Vin	GND	-Vo	0V	+Vo
VBS	1	2	-	4	6
VBD	14	1	-	11	9

PINS DESCRIPTION

SIP	Connection		DIP
	+Vin	+Vin	
1	+Vin	+Vin	14
2	GND	GND	1
4	0V	0V	11
6	+Vo	+Vo	9
3,5,7	omitted	NC	7
		omitted	2,3,4,5,6,8,10,12,13

Note: PIN"7" can't connect any component.

SHENZHEN SUNYUAN TECHNOLOGY CO., LTD.

Meihua Rd. Futian District,

Shenzhen 518049, China

Tel: +86-755-83100080

Fax: +86-755-83116652

Email: sales02@szsunyuan.com

www.szsunyuan.com