

Silicon NPN Power Transistors

TIP150/151/152

DESCRIPTION

- With TO-220C package
- DARLINGTON

APPLICATIONS

- For use in automotive ignition, switching and motor control applications

PINNING

PIN	DESCRIPTION
1	Base
2	Collector; connected to mounting base
3	Emitter

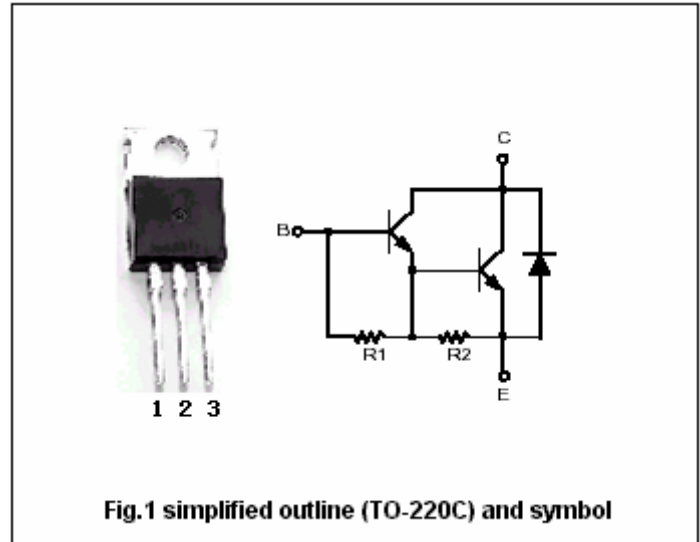
ABSOLUTE MAXIMUM RATINGS($T_c=25^\circ\text{C}$)

SYMBOL	PARAMETER	CONDITIONS	VALUE	UNIT
V_{CBO}	Collector-base voltage	TIP150	300	V
		TIP151	350	
		TIP152	400	
V_{CEO}	Collector-emitter voltage	TIP150	300	V
		TIP151	350	
		TIP152	400	
V_{EBO}	Emitter-base voltage	Open collector	8	V
I_C	Collector current-DC		7	A
I_{CM}	Collector current-Pulse		10	A
I_B	Base current-DC		1.5	A
P_C	Collector power dissipation	$T_c=25^\circ\text{C}$	80	W
T_j	Junction temperature		150	$^\circ\text{C}$
T_{stg}	Storage temperature		-65~150	$^\circ\text{C}$

THERMAL CHARACTERISTICS

SYMBOL	PARAMETER	VALUE	UNIT
$R_{th\ j-c}$	Thermal resistance junction to case	1.56	$^\circ\text{C}/\text{W}$

Silicon NPN Power Transistors

TIP150/151/152

CHARACTERISTICS

T_j=25 °C unless otherwise specified

SYMBOL	PARAMETER	CONDITIONS	MIN	TYP.	MAX	UNIT	
V _{(BR)CEO}	Collector-emitter breakdown voltage	TIP150	I _C =10mA, I _B =0	300			V
		TIP151		350			
		TIP152		400			
V _{(BR)CBO}	Collector-base breakdown voltage	TIP150	I _C =1mA, I _E =0	300			V
		TIP151		350			
		TIP152		400			
V _{CE(sat)-1}	Collector-emitter saturation voltage	I _C =1A, I _B =10mA			1.5	V	
V _{CE(sat)-2}	Collector-emitter saturation voltage	I _C =2A, I _B =100mA			1.5	V	
V _{CE(sat)-3}	Collector-emitter saturation voltage	I _C =5A, I _B =250mA			2.0	V	
V _{BE(sat)-1}	Base-emitter saturation voltage	I _C =2A, I _B =100mA			2.2	V	
V _{BE(sat)-2}	Base-emitter saturation voltage	I _C =5A, I _B =250mA			2.3	V	
I _{CEO}	Collector cut-off current	TIP150	V _{CE} =300V, I _B =0			250	μA
		TIP151		V _{CE} =350V, I _B =0			
		TIP152		V _{CE} =400V, I _B =0			
I _{EBO}	Emitter cut-off current	V _{EB} =8V; I _C =0			15	mA	
h _{FE-1}	DC current gain	I _C =2.5A; V _{CE} =5V	150				
h _{FE-2}	DC current gain	I _C =5A; V _{CE} =5V	50				
h _{FE-3}	DC current gain	I _C =7A; V _{CE} =5V	15				
V _F	Diode forward voltage	I _F =7A			3.5	V	
C _{OB}	Output capacitance	I _E =0; V _{CB} =10V; f=1MHz			150	pF	

Switching times

t _d	Delay time	V _{CC} =250V; I _C =5A I _{B1} =-I _{B2} =250mA t _p =20μs; Duty Cycle≤2.0%		0.03		μs
t _r	Rise time			0.18		μs
t _s	Storage time			3.5		μs
t _f	Fall time			1.6		μs

Silicon NPN Power Transistors

TIP150/151/152

PACKAGE OUTLINE

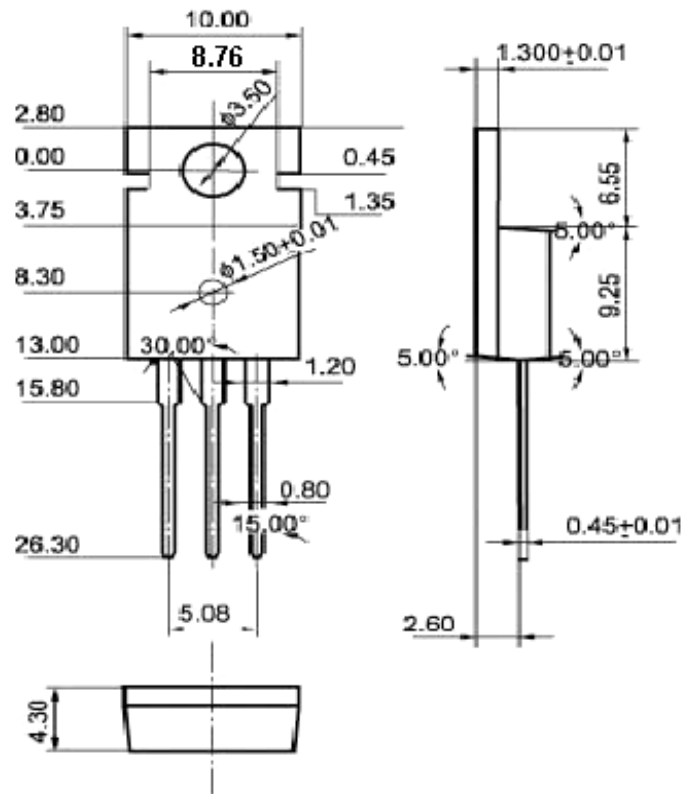

Fig.2 Outline dimensions (unindicated tolerance: ± 0.1 mm)